



# REPLACEMENT PARTS

CATALOGUE No. 3

**UNIT CONSTRUCTION 650 c.c. TWINS**

6T THUNDERBIRD

TR6 TROPHY

T120 BONNEVILLE 120

From engine No. DU 13375

[See Bookmarks](#)

**TRIUMPH ENGINEERING COMPANY LIMITED**  
**MERIDEN WORKS · ALLESLEY · COVENTRY · ENGLAND**  
TELEPHONE MERIDEN 331                      TELEGRAMS "TRUSTY COVENTRY"

REF. 916/64

## TRIUMPH GUARANTEE

1. In this Guarantee the word "machine" refers to the motor cycle, scooter, motor cycle combination or sidecar as the case may be, purchased by the Purchaser.
2. In order to obtain the benefit of this Guarantee, the Purchaser must have correctly completed the registration form and returned it to us within fourteen days of the purchase.
3. We will supply, free of charge, a new part in exchange for, or, if we consider repair sufficient, will repair free of charge any part proved within six months of the date of purchase of any new machine, (three months overseas) or within three months of its renewal or repair in the case of a part already renewed or repaired, to be defective by reason of our faulty workmanship or materials. We do not undertake to bear the cost of fitting such new or repaired part or accessory.
4. Any part considered to be defective must be sent to our Works, carriage paid, accompanied by the following information:—
  - (a) Name of purchaser and his address;
  - (b) Date of purchase of machine;
  - (c) Name of dealer from whom the purchase was made;
  - (d) Engine number and model.
5. This Guarantee shall not extend to defects or damage appearing after misuse, neglect, abnormal stress or strain, or the incorporation or affixing of unsuitable attachments or parts and in particular:—
  - (a) Hiring out;
  - (b) Racing and Competitions;
  - (c) Adaptation or alteration of any part or parts after leaving our Works;
  - (d) The attaching of a sidecar in a manner not approved by us or to an unsuitable motor cycle.

This Guarantee shall not extend to machines whose trade mark, name or manufacturing number has been altered or removed, or in which has been used any part not supplied or approved by us, or to tyres, saddles, chains, speedometers, revolution counters and electrical equipment or to parts supplied to the order of the Purchaser and different from our standard specification.
6. Our liability and that of our dealer who sells the machine, shall be limited to that set out in this guarantee, and no other claims including claims for consequential damage or injury to person or property, shall be admissible. All other conditions and warranties statutory or otherwise and whether express or implied are hereby excluded and no guarantee other than that expressly herein contained applies to the machine to which this Guarantee relates or any accessory or part thereof.
7. We reserve the right to modify or deviate from the Published Specification without notice.

## REPAIRS GUARANTEE

1. Whilst the highest standard of workmanship and materials is aimed at, we cannot accept liability for any defects appearing more than three months after the machine, assembly or component has left our Works after being repaired.
2. We will repair or replace at our option free of charge any defective work, materials or parts relating to the repairs carried out by us appearing within that time but shall not be under any further or other liability for any other loss or damage whether direct or consequential and our liability shall be limited to the cost of so making good. We do not undertake to bear the cost of fitting any replacement or repaired part.
3. We do not accept liability in respect of parts of proprietary manufacture, e.g. tyres, saddles, chains, speedometers, revolution counters and electrical equipment which may be used by us in effecting a repair. All other conditions and warranties statutory or otherwise express or implied are hereby excluded.

# ILLUSTRATION INDEX

<i>Fig. No.</i>	<i>Description</i>	<i>Page No.</i>
1	CRANKSHAFT AND CONNECTING RODS ... ..	12
2	CRANKCASE ... ..	14
3	OIL PUMP AND RELEASE VALVE AND MANIFOLD ... ..	16
4	CYLINDER BLOCK AND HEAD, 6T AND TR6 ... ..	18
5	CYLINDER BLOCK AND HEAD, T120 ... ..	20
6	TIMING COVER, CONTACT BREAKER AND COILS ... ..	22
7	GEARBOX INNER COVER AND SELECTORS ... ..	24
8	GEARBOX SHAFTS AND GEARS ... ..	26
9	GEARBOX OUTER COVER ... ..	28
10	CLUTCH ... ..	30
11	CHAINCASE AND CHAINS ... ..	32
12	FRAME ... ..	34
13	SWINGING FORK AND SUSPENSION UNITS ... ..	36
14	ENGINE UNIT FITTINGS AND FOOTRESTS ... ..	38
15	EXHAUST PIPES AND SILENCERS ... ..	40
16	TELESCOPIC FRONT FORKS, 6T ... ..	42
17	NACELLE HEADLAMP AND SWITCHES ... ..	44
18	TELESCOPIC FRONT FORK, TR6 AND T120 ... ..	46
19	FRONT WHEEL ... ..	48
20	REAR WHEEL ... ..	50
21	QUICKLY DETACHABLE REAR WHEEL ... ..	52
22	PETROL TANKS ... ..	54
23	OIL TANK ... ..	56
24	BATTERY CARRIER AND AIR FILTER ... ..	58
25	PANELS AND TWINSEAT ... ..	60
26	MUDGUARDS ... ..	62
27	HANDLEBARS AND CONTROL LEVERS ... ..	64
28	CONTROL CABLES AND AMERICAN HANDLEBARS ... ..	66
29	TOOLKIT, FRAME LOCK, PILLION FOOTRESTS AND LICENCE HOLDER ... ..	68
30	AMAL CARBURETTER, 6T ... ..	70
31	AMAL CARBURETTER, TR6 AND T120 ... ..	72
32	HEADLAMP, WIRING HARNESS, HORN AND RECTIFIER ... ..	74
33	SPEEDOMETER, TACHOMETER AND TAIL LAMP ... ..	76

# INDEX

	<i>Page</i>		<i>Page</i>
AIR FILTER ... ..	59	MANIFOLD ... ..	17
ALTERNATOR ... ..	13, 33	MUDGUARDS ... ..	63
BATTERY CARRIER ... ..	59	NACELLE ... ..	45
CARBURETTER ... ..	71, 73	OIL PUMP ... ..	17
CARTON PACKS ... ..	9	OIL TANK ... ..	57
CENTRE STAND ... ..	35	PETROL TANK ... ..	55
CHAINCASE ... ..	33	PILLION FOOTRESTS ... ..	69
CHAINS ... ..	33	PISTONS ... ..	13
CLUTCH ... ..	31	PROP STAND ... ..	35
COIL ... ..	23	Q.D. REAR WHEEL ... ..	53
CONTACT BREAKER ... ..	23	REAR PANELS ... ..	61
CONTROL CABLES ... ..	67	REAR WHEEL ... ..	51
CONTROL LEVERS ... ..	65	RECTIFIER ... ..	75
CRANKCASE ... ..	15	SILENCERS ... ..	41
CRANKSHAFT ... ..	13	SPARK PLUGS ... ..	23
CYLINDER HEAD ... ..	19, 21	SPEEDOMETER ... ..	77
ENGINE PLATES ... ..	39	STEERING RACES ... ..	35
EXHAUST PIPES ... ..	41	SUSPENSION UNITS ... ..	37
FOOTRESTS ..... ..	39	SWITCHES ... ..	37, 45, 75
FRONT FORKS ... ..	43, 47	TIMING GEARS ... ..	13
FRONT WHEEL ... ..	49	TOOLKIT ... ..	69
GASKET SETS ... ..	10	TWINSEAT ... ..	61
GEARBOX ... ..	25, 27, 29	VALVES ... ..	19, 21
HANDLEBARS ... ..	65	WIRING HARNESS ... ..	45, 75
HORN ... ..	45	ZENER DIODE ... ..	45

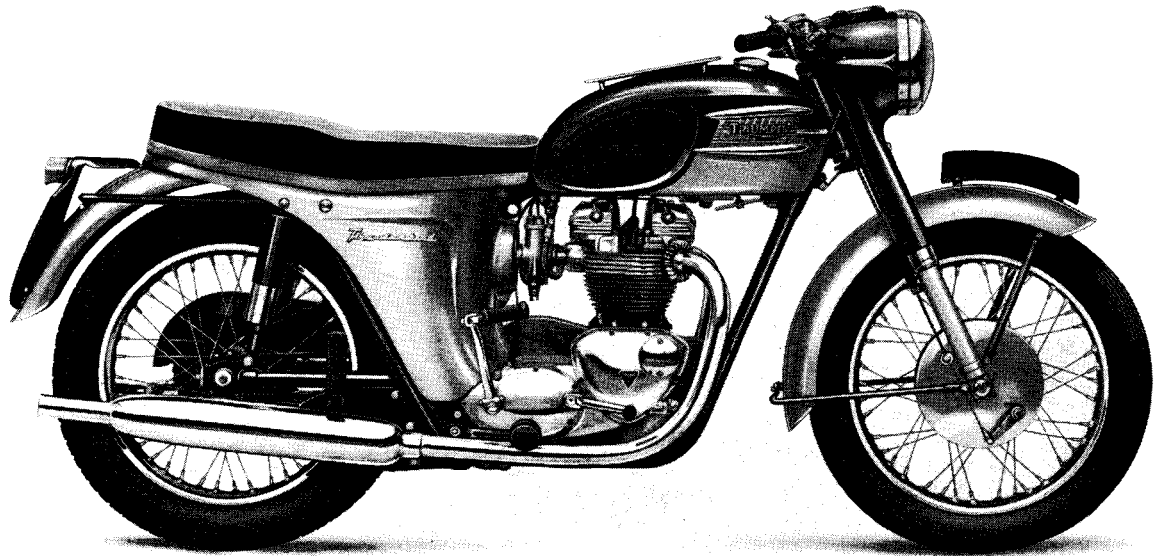

### THUNDERBIRD (6T) TECHNICAL DATA

<b>Bore and stroke</b>	...	...	...	...	...	...	...	...	...	...	71 × 82 mm. 2.79 × 3.23 ins.
<b>Capacity</b>	...	...	...	...	...	...	...	...	...	...	649 c.c. (40 cu. ins.)
<b>Compression ratio</b>	...	...	...	...	...	...	...	...	...	...	7.5 : 1
<b>Sparking plugs</b>	...	...	...	...	...	...	...	...	...	...	Champion N4
<b>Carburetter</b>	...	...	...	...	...	...	...	...	...	...	Amal Monobloc 376
					Main jet	...	...	...	...	...	230
					Needle jet	...	...	...	...	...	.106
					Needle	...	...	...	...	...	Type C
					Throttle valve	...	...	...	...	...	376/4
					Pilot jet	...	...	...	...	...	25
<b>Gearbox sprocket</b>	...	...	...	Solo	...	...	...	...	...	...	20 teeth
				Sidecar	...	...	...	...	...	...	18 teeth
<b>Chains</b>	...	...	...	Front	...	...	...	...	...	...	$\frac{3}{8}$ " Duplex × 84 links
				Rear	...	...	...	...	...	Solo	$\frac{5}{8}$ " × $\frac{3}{8}$ " × 103 links
										Sidecar	$\frac{5}{8}$ " × $\frac{3}{8}$ " × 102 links
<b>Capacities</b>	...	...	...	Fuel Tank	...	...	...	...	...	...	4 galls. (18 litres)
				Oil Tank	...	...	...	...	...	...	5 pints (2.8 litres)
				Gearbox	...	...	...	...	...	...	$\frac{7}{8}$ pint (500 c.c.)
				Primary Chaincase	...	...	...	...	...	...	$\frac{5}{8}$ pint (350 c.c.)
				Front Forks (each leg)	...	...	...	...	...	...	$\frac{1}{3}$ pint (190 c.c.)
<b>Brakes</b>	...	...	...	Front, diameter	...	...	...	...	...	...	8" (20.32 cms.)
				Rear, diameter	...	...	...	...	...	...	7" (17.78 cms.)
<b>Tyre size</b>	...	...	...	Front	...	...	...	...	...	...	3.25 × 18
				Rear	...	...	...	...	...	...	3.50 × 18

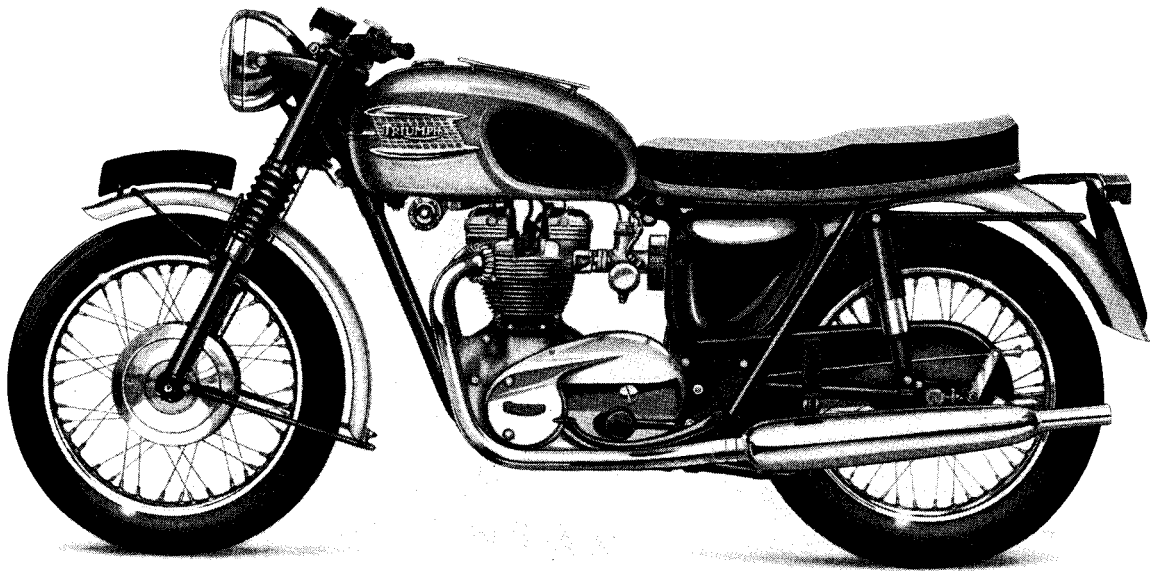

### TROPHY (TR6) TECHNICAL DATA

<b>Bore and stroke</b>	...	...	...	...	...	...	...	...	...	71 × 82 mm. 2.79 × 3.23 ins.
<b>Capacity</b>	...	...	...	...	...	...	...	...	...	649 c.c. (40 cu. ins.)
<b>Compression ratio</b>	...	...	...	...	...	...	...	...	...	8.5 : 1
<b>Sparking plugs</b>	...	...	...	...	...	...	...	...	...	Champion N4
<b>Carburetter</b>	...	...	...	...	...	...	...	...	...	Amal Monobloc 389
										Main jet ... 310
										Needle jet ... .106
										Needle ... Type D
										Throttle valve ... 389/3½
										Pilot jet ... 25
<b>Gearbox sprocket</b>	...	...	...	...	...	...	...	Solo	...	19 teeth
								Sidecar	...	17 teeth
<b>Chains</b>	...	...	...	...	Front	...	...	...	...	¾" Duplex × 84 links
					Rear	...	...	Solo	...	⅝" × ⅜" × 103 links
								Sidecar	...	⅝" × ⅜" × 102 links
<b>Capacities</b>	...	...	...	...	Fuel Tank	...	...	...	...	4 galls. (18 litres)
					Oil Tank	...	...	...	...	5 pints (2.8 litres)
					Gearbox	...	...	...	...	⅞ pint (500 c.c.)
					Primary Chaincase	...	...	...	...	⅝ pint (350 c.c.)
					Front Forks (each leg)	...	...	...	...	⅓ pint (190 c.c.)
<b>Brakes</b>	...	...	...	...	Front, diameter...	...	...	...	...	8 in. (20.32 cm.)
					Rear, diameter	...	...	...	...	7 in. (17.78 cm.)
<b>Tyre size</b>	...	...	...	...	Front	...	...	...	...	3.25 × 19
					Rear	...	...	...	...	4.00 × 18

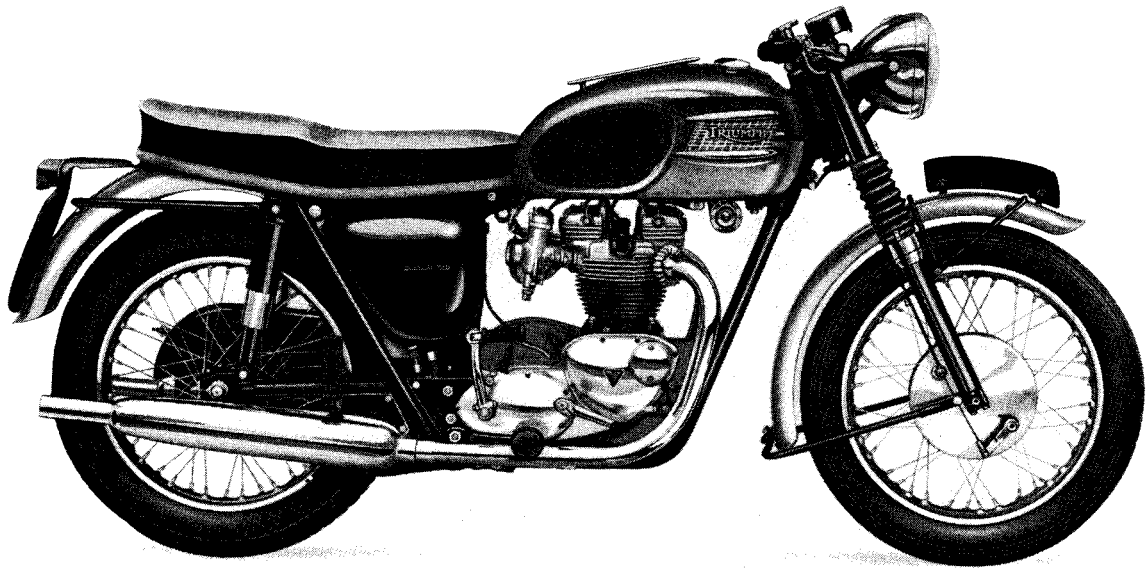

### BONNEVILLE 120 (T120) TECHNICAL DATA

<b>Bore and stroke</b>	...	...	...	...	...	...	...	...	...	71 × 82 mm. 2.79 × 3.23 ins.
<b>Capacity</b>	...	...	...	...	...	...	...	...	...	649 c.c. (40 cu. ins.)
<b>Compression ratio</b>	...	...	...	...	...	...	...	...	...	8.5 : 1
<b>Sparking plugs</b>	...	...	...	...	...	...	...	...	...	Champion N4
<b>Carburetters</b>	...	...	...	...	...	...	...	...	...	2 Amal Monobloc 389
					Main jet	...	...	...	...	260
					Needle jet	...	...	...	...	.106
					Needle	...	...	...	...	Type D
					Throttle valve	...	...	...	...	389/3
					Pilot jet	...	...	...	...	25
<b>Gearbox sprocket</b>	...	...	...	...	...	...	...	Solo	...	19 teeth
								Sidecar	...	17 teeth
<b>Chains</b>	...	...	...	...	Front	...	...	...	...	$\frac{3}{8}$ " Duplex × 84 links
					Rear	...	...	...	...	$\frac{5}{8}$ " × $\frac{3}{8}$ " × 103 links
								Solo	...	$\frac{5}{8}$ " × $\frac{3}{8}$ " × 102 links
								Sidecar	...	$\frac{5}{8}$ " × $\frac{3}{8}$ " × 102 links
<b>Capacities</b>	...	...	...	...	Fuel Tank	...	...	...	...	4 galls. (18 litres)
					Oil Tank	...	...	...	...	5 pints (2.8 litres)
					Gearbox	...	...	...	...	$\frac{7}{8}$ pint (500 c.c.)
					Primary Chaincase	...	...	...	...	$\frac{5}{8}$ pint (350 c.c.)
					Front Forks (each leg)	...	...	...	...	$\frac{1}{3}$ pint (190 c.c.)
<b>Brakes</b>	...	...	...	...	Front, diameter	...	...	...	...	8 in. (20.32 cm.)
					Rear, diameter	...	...	...	...	7 in. (17.78 cm.)
<b>Tyre size</b>	...	...	...	...	Front	...	...	...	...	3.25 × 18
					Rear	...	...	...	...	3.50 × 18

## CARTON PACK LIST

The following sub-assemblies are supplied in carton packs under the C.P. part number stated. The contents of these carton packs are preserved and will not deteriorate under adverse conditions.

Part No.	Contents
<b>Brake Lining</b>	
C.P.38/A.M.2 ... .. 2 ... ..	NW243 ... .. Brake lining
16 ... ..	W129 ... .. Rivet
C.P.184 ... .. 2 ... ..	W1414 ... .. Brake lining
16 ... ..	W129 ... .. Rivet
<b>Pistons</b>	
C.P.199 ... .. 1 ... ..	E4899 ... .. Piston C.R. 7.5 : 1
2 ... ..	E3049 ... .. Compression ring
1 ... ..	E2898 ... .. Oil control ring
1 ... ..	WE203E ... .. Gudgeon pin
2 ... ..	WE479 ... .. Circlip
C.P.199 is also available in 0.010 in., 0.020 in. and 0.040 in. oversizes.	
C.P.200 ... .. 1 ... ..	E5329 ... .. Piston C.R. 8.5 : 1
2 ... ..	E3049 ... .. Compression ring
1 ... ..	E2898 ... .. Oil control ring
1 ... ..	WE203E ... .. Gudgeon pin
2 ... ..	WE479 ... .. Circlip
C.P. 200 is also available in 0.010 in., 0.020 in. and 0.040 in. overseas.	
C.P.202 ... .. 1 ... ..	E5819 ... .. Piston C.R. 11 : 1 (Alcohol fuel)
2 ... ..	E3049 ... .. Compression ring
1 ... ..	E2898 ... .. Oil control ring
1 ... ..	WE203E ... .. Gudgeon pin
2 ... ..	WE479 ... .. Circlip
<b>Piston Rings</b>	
C.P. 99 ... .. 4 ... ..	E3049 ... .. Compression ring
2 ... ..	E2898 ... .. Oil control ring
C.P. 99 is also available in 0.010 in., 0.020 in. and 0.040 in. oversizes.	
<b>Valve springs</b>	
C.P.188 ... .. 4 ... ..	E4221 ... .. Inner spring (Red spot)
(6T) ... .. 4 ... ..	E4222 ... .. Outer spring (Red spot)
C.P.102 ... .. 4 ... ..	E3001 ... .. Inner spring (White spot)
(TR6, T120) ... .. 4 ... ..	E3002 ... .. Outer spring (White spot)



## CARTON PACK LIST — continued

Part No.	Contents
<b>Valves</b>	
C.P.173 ... .. 2 ... .. E3310 ... ..	Inlet valve
(6T, TR6) ... .. 2 ... .. E3927 ... ..	Exhaust valve
<b>Valve Guides</b>	
C.P.97 ... .. 2 ... .. E2899 ... ..	Inlet guide
(6T, TR6) ... .. 2 ... .. E2900 ... ..	Exhaust guide
<b>De-coke Gasket Set</b> All models ... ..	D/GS1

## HOW TO USE THIS PARTS CATALOGUE

First check that the engine number of your machine is subsequent to that quoted on the title page.

Next consult the index on Page 5 for the parts or group of parts which you wish to locate. When you have located the parts make sure from the end columns that the part you have located does apply to your machine.

List the quantities required as single units; do not ask for "2 pairs" or "3 dozen".

In case of painted items always state the colour required. Painted parts are available only in the colours or alternatives specified for that model of that particular year.

<i>Colour</i>	<i>Suffix Letter to Part No.</i>
BLACK ... ..	W
SILVER ... ..	V
BURNISHED GOLD/ALASKAN WHITE	BG/AW
PACIFIC BLUE ... ..	PB

N.B. Pacific Blue is a flamboyant finish applied over Silver Sheen.

Paint is available also in all colours in ¼ pint or 1 gallon tins.

### PLEASE NOTE

THROUGHOUT THIS LIST, ASSEMBLIES ARE PRINTED IN CAPITALS AND THE COMPONENTS INCLUDED IN THAT ASSEMBLY ARE INDENTED IN THE DESCRIPTION COLUMN, REVERTING TO THE ORIGINAL ALIGNMENT WHEN THE ASSEMBLY IS COMPLETE. TO ORDER THE COMPLETE ASSEMBLY IT IS NECESSARY ONLY TO QUOTE THE ASSEMBLY NUMBER. ANY COMPONENT PARTS LISTED MAY ALSO BE OBTAINED SEPARATELY IF REQUIRED.

### SPECIAL WORKSHOP TOOLS

A COMPLETE LIST OF WORKSHOP TOOLS CAN BE MADE AVAILABLE BY EITHER CONTACTING YOUR DEALER OR APPLYING DIRECT TO THE TRIUMPH SERVICE DEPARTMENT. IN MOST CASES THESE TOOLS ARE VERY COSTLY AS THEY ARE MADE ENTIRELY FOR WORKSHOP USE, AND THEREFORE, IT IS NOT RECOMMENDED THAT THE PRIVATE OWNER PURCHASES THE TOOLS IN ORDER TO AID SERVICING THE MACHINE ONCE OR TWICE ONLY. IN THESE CIRCUMSTANCES IT IS FAR MORE ECONOMICAL TO GET IN TOUCH WITH A RECOGNISED DEALER.

# TRIUMPH SPARES

**HOW TO ORDER.** Every part is indicated by a number, and this should be quoted together with the description. In order to assist customers, dimensions have been given in many cases where parts are similar. Parts where possible have been listed in order of assembly and a number of the illustrations show the assembly order also. With these aids, there should be no difficulty in identifying the parts you require.

ALWAYS HEAD YOUR ORDER WITH THE ENGINE NUMBER, STAMPED ON THE LEFT SIDE OF THE ENGINE JUST BELOW THE CYLINDER, TOGETHER WITH THE PREFIX LETTERS.

**WHERE TO OBTAIN.** Triumph Spare Parts can only be obtained from an authorised Triumph Dealer, and we recommend our customers to place their orders with the Triumph Dealer in their district. When parts not usually asked for are required, and for which the Dealer may have to write or obtain specially, the postage or carriage incurred becomes payable.

TRIUMPH SPARES ARE NOT SUPPLIED TO PRIVATE OWNERS DIRECT FROM THE FACTORY. A LIST OF AUTHORISED DEALERS WHO STOCK TRIUMPH SPARES IS AVAILABLE ON REQUEST. IF DIFFICULTY IS EXPERIENCED IN OBTAINING THE REQUIRED PARTS, THE MATTER SHOULD BE TAKEN UP DIRECTLY WITH THE TRIUMPH SPARES DEPARTMENT.

Customers are warned against the risk incurred by purchasing parts that are not of genuine Triumph manufacture. This risk is eliminated if parts are ordered as instructed from recognised Dealers.

**PATTERNS AND PARTS FOR REPAIR.** It is not necessary to send patterns if the part number is quoted. The sending of patterns often delays the order as parcel post or rail takes longer than letter post.

Parts sent to Coventry for repair, replacement, or as patterns should bear the sender's Name and Address and clear instructions should accompany the parts. In your own interest send a copy of the advice note under separate cover. All parts must be forwarded carriage paid and care should be taken to ensure that all remittances are sent separately and not enclosed with the parts. Fragile units such as cylinders, etc., should always be boxed to avoid damage in transit. Complete machines should have all fitments such as windscreens, driving mirrors, tools, etc., removed by the sender before despatch, as it is impossible for us to accept responsibility in the event of loss in transit. We are always pleased to give estimates for overhauling and repairs, but should an estimate not be accepted, a charge will be made covering cost of dismantling and re-assembling, if carried out.

Communications relating to Parts should be addressed to the SPARES DEPARTMENT and for repairs, guarantee claims and technical advice to the SERVICE DEPARTMENT, Triumph Engineering Co. Ltd., Meriden Works, Allesley, Coventry. In order to facilitate quick reference, the quoting of any number, invoice number or reference from previous communications is essential. Accessories not of our manufacture should be sent direct to the actual makers, whose Name and Addresses appear below.

## PROPRIETARY GROUP

Ancillary equipment which is fitted to our motor cycles is of the highest quality and is guaranteed by the manufacturers and not by ourselves. Any repairs or claims should be directed to the actual makers or their local agents who will always give owners every possible assistance. The following are the addresses of the various manufacturers:—

### **CARBURETTERS.**

Messrs. Amal Ltd.,  
Holdford Road,  
Witton,  
Birmingham, 6.

### **CHAINS.**

Renold Chains Ltd.,  
Wythenshawe,  
Manchester.

### **ELECTRICAL EQUIPMENT.**

Messrs. J. Lucas Ltd.,  
Gt. Hampton Street,  
Birmingham, 18.

### **TYRES.**

Dunlop Rubber Co. Ltd.,  
Fort Dunlop,  
Birmingham, 24.

The Avon India Rubber Co. Ltd.,  
Melksham,  
Wilts.

### **SPARKING PLUGS.**

Champion Sparking Plug Co. Ltd.,  
Feltham,  
Middlesex.

### **SPEEDOMETERS.**

Messrs. Smiths Motor Accessories Ltd.,  
Cricklewood Works,  
London, N.W.2.

### **SUSPENSION UNITS.**

Messrs. Girling Ltd.,  
Kings Road,  
Tyseley,  
Birmingham, 11.

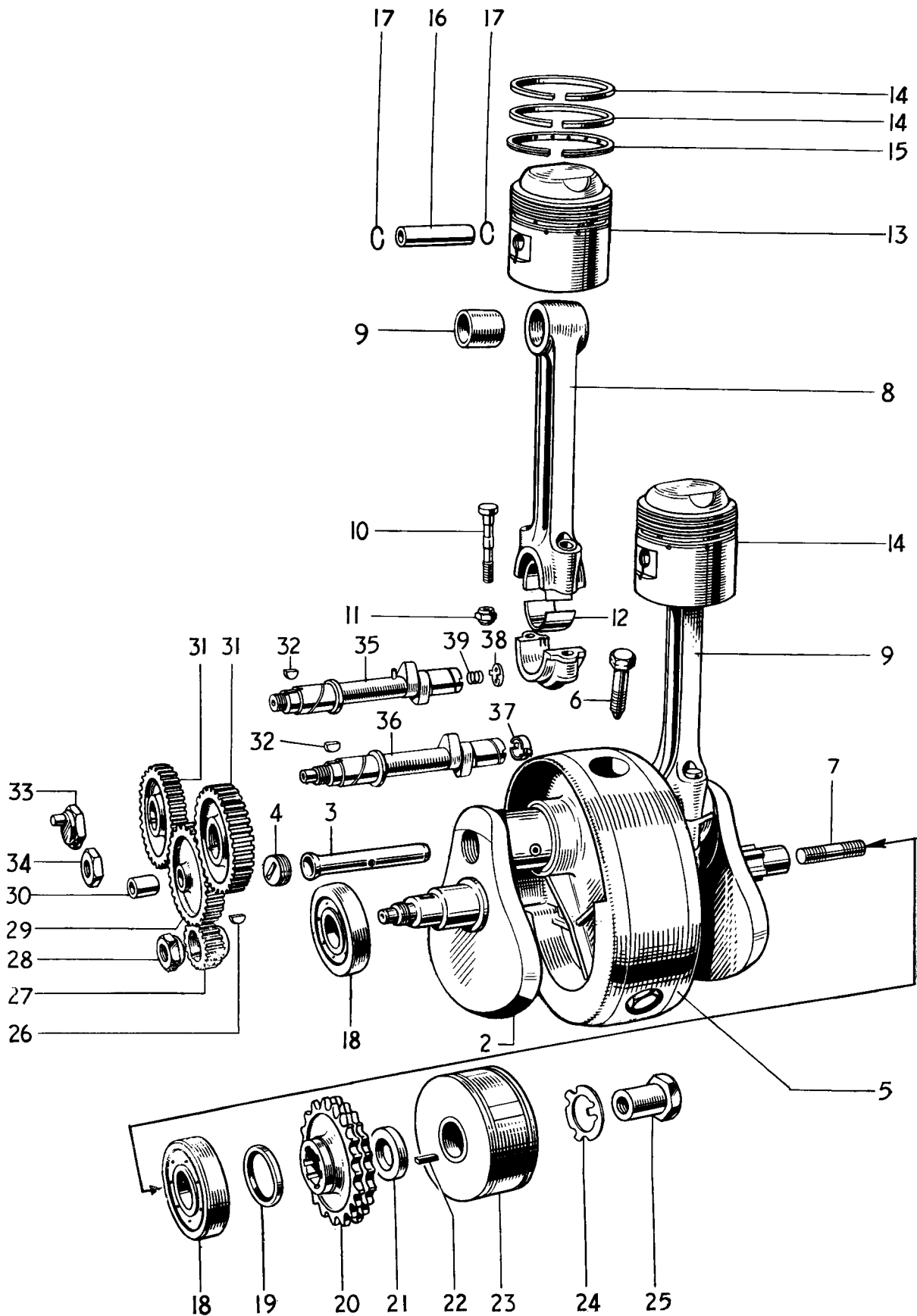

Fig. 1. CRANKSHAFT AND CONNECTING RODS

Ref. No.	Part No.	DESCRIPTION	QUANTITY		
----------	----------	-------------	----------	--	--

### CRANKSHAFT AND CONNECTING RODS

			6T	TR6	T120
1	E5867	CRANKSHAFT AND FLYWHEEL ASSEMBLY ...	1	1	1
2	E4643	CRANKSHAFT C/W. OIL TUBE ...	1	1	1
3	E3903	Oil tube ...	1	1	1
4	E3905	Screwed plug ...	1	1	1
5	E5783	Flywheel ...	1	1	1
6	*E3907	Flywheel bolt ...	3	3	3
7	E3114	Crankshaft stud (1 $\frac{3}{16}$ " O.A.) ...	1	1	1
8	E3606	CONNECTING ROD ...	2	-	-
8	E3606T	CONNECTING ROD ...	-	2	2
9	E1511	Small end bush ...	2	2	2
10	E2490A	Connecting rod bolt ...	4	4	4
11	E2922	Self locking nut ...	4	4	4
12	E3586	Big end bearing ...	4	4	4
13	CP199	PISTON COMPLETE 7-5:1 C.R. ...	2	-	-
13	CP200	PISTON COMPLETE 8-5:1 C.R. ...	-	2	2
14	E3049	Taper compression ring ...	4	4	4
15	E2898	Oil control ring ...	2	2	2
16	WE203E	Gudgeon pin ...	2	2	2
17	WE479	Circlip ...	4	4	4
18	E1591	Main bearing ...	2	2	2
19	E3876	Oil seal ...	1	1	1
20	E5446	Engine sprocket, 29 teeth Duplex ...	1	1	1
21	E4573	Distance piece ...	1	1	1
22	E3974	Rotor key ...	1	1	1
23	54213901	Rotor, type RM19 ...	1	1	1
24	E3975	Tab washer ...	1	1	1
25	E3977	Nut ...	1	1	1
26	E1580	Key ...	1	1	1
27	E5447	Timing pinion ...	1	1	1
28	E4565	Nut ...	1	1	1
29	E4566	INTERMEDIATE WHEEL ...	1	1	1
30	E400	Intermediate wheel bush... ...	1	1	1
31	E4562	Camshaft wheel... ...	2	2	2
32	E1558	Camshaft key ...	2	2	2
33	E1463	Inlet camshaft nut ...	1	1	1
34	E4563	Exhaust camshaft nut ...	1	1	1
35	E4818	Inlet camshaft ...	1	-	-
35	E4819	Inlet camshaft ...	-	1	1
36	E4848	Exhaust camshaft ...	1	-	-
36	E4855	EXHAUST CAMSHAFT ...	-	1	1
37	E4700	Tachometer drive thimble ...	-	1	1
38	E5316	Rotary breather valve ...	1	1	1
39	E2256	Breather valve spring ...	1	1	1

\* Use D524 Loctite Sealant

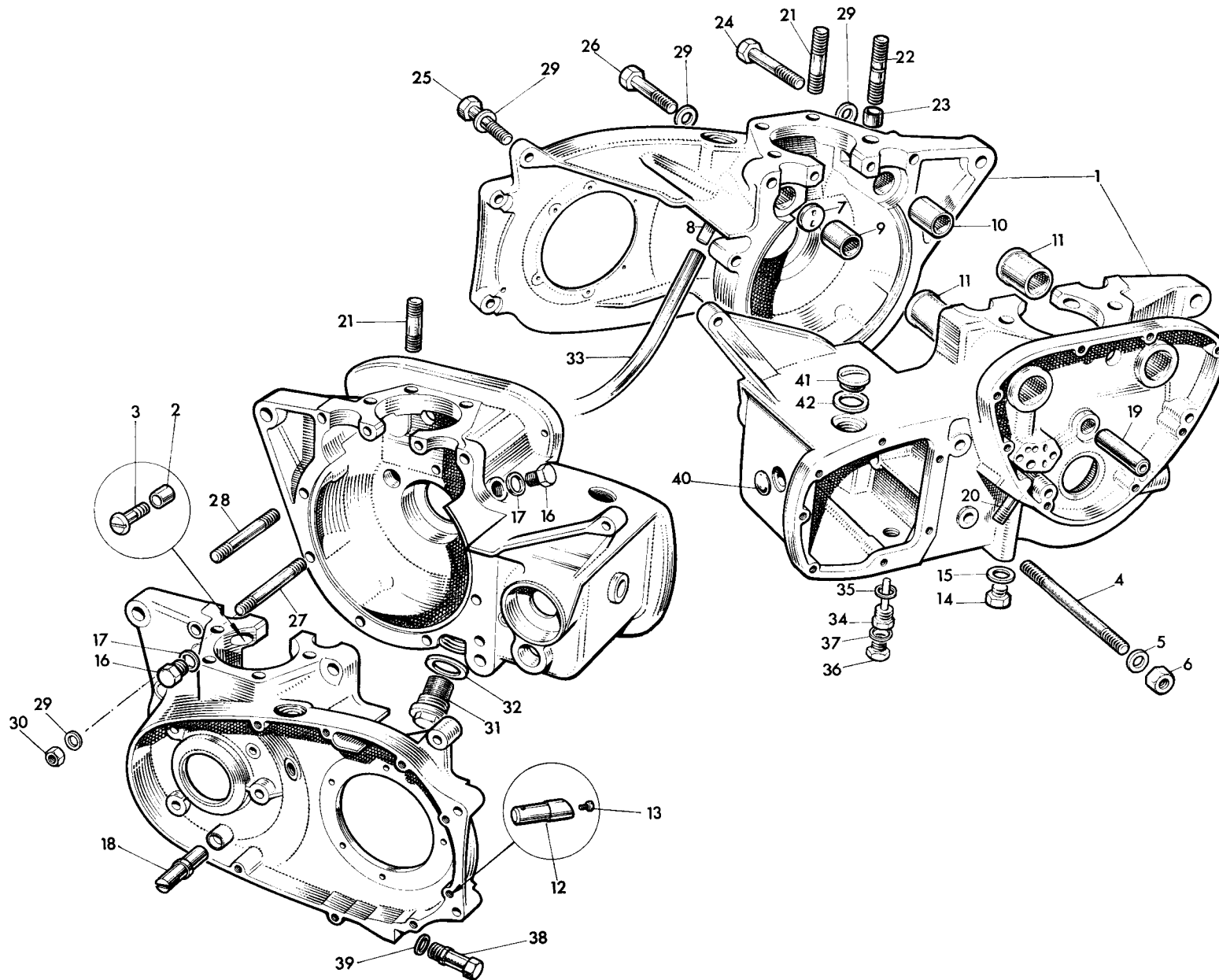

Fig. 2. CRANKCASE

Ref. No.	Part No.	DESCRIPTION	QUANTITY			
<b>CRANKCASE</b>						
			6T	TR6	T120	
1	E5871/4534	CRANKCASE ... ..	1	1	1	
2	E3716	Hollow Dowel ... ..	1	1	1	
3	E5232	Screw ( $\frac{21}{32}$ in. U.H.) ... ..	2	2	2	
4	E4542	Stud ( $4\frac{1}{2}$ in. O.A.) ... ..	2	2	2	
5	S25-2	Plain washer ... ..	2	2	2	
6	P0172A	Nut ... ..	2	2	2	
7	GS87	Breather disc ... ..	1	1	1	
8	E2724	Breather pipe ... ..	1	1	1	
9	E2260	Inlet camshaft bush ... ..	1	1	1	
10	E1516	Exhaust camshaft bush ... ..	1	1	1	
11	E1479	Camshaft bush ... ..	2	2	2	
12	E4744	Chain oiler tube ... ..	1	1	1	
13	E3885	Chain oiler jet ... ..	1	1	1	
13	H689	Blanking screw ... ..	A	A	A	
14	E4539	Oilway plug ... ..	1	1	1	
15	GS439	Fibre washer ... ..	1	1	1	
16	E4706	Tachometer drive plug ... ..	2	2	2	
17	T1257	Fibre washer ... ..	2	2	2	
18	E4147	Chain tensioner abutment ... ..	1	1	1	
19	E375	Intermediate wheel spindle ... ..	1	1	1	
20	E3717	Oil pipe stud ( $1\frac{1}{2}$ in. O.A.) ... ..	1	1	1	
21	E672	Cylinder stud ( $1\frac{5}{8}$ in. O.A.) ... ..	6	6	6	
22	E3523	Cylinder stud ( $1\frac{5}{8}$ in. O.A.) ... ..	2	2	2	
23	E1534A	Hollow dowel ... ..	2	2	2	
24	E4541	Bolt ( $2\frac{1}{2}$ in. U.H.) ... ..	1	1	1	
25	E4540	Bolt ( $1\frac{3}{4}$ in. U.H.) ... ..	1	1	1	
26	E4098	Bolt ( $1\frac{7}{8}$ in. U.H.) ... ..	1	1	1	
27	E4856	Stud ( $5\frac{1}{16}$ in. O.A.) ... ..	1	1	1	
28	E2888	Stud ( $3\frac{7}{8}$ in. O.A.) ... ..	3	3	3	
29	S25-3	Plain washer ... ..	11	11	11	
30	S1-51	Nut ... ..	8	8	8	
31	E5312	Crankcase filter... ..	1	1	1	
32	E5315	Copper washer ... ..	1	1	1	
33	E5375	Breather extension pipe ... ..	1	1	1	
34	T1112	Drain plug (with level tube) ... ..	1	1	1	
35	T1257	Fibre washer ... ..	1	1	1	
36	T361	Level plug ... ..	1	1	1	
37	WE170	Fibre washer ... ..	1	1	1	
38	E4922	Drain and adjuster plug ... ..	1	1	1	
39	T1738	Fibre washer ... ..	1	1	1	
40	T1920	Blanking plug ... ..	2	2	2	
41	E732	Filler plug ... ..	2	2	2	
42	NE507	Fibre washer ... ..	2	2	2	

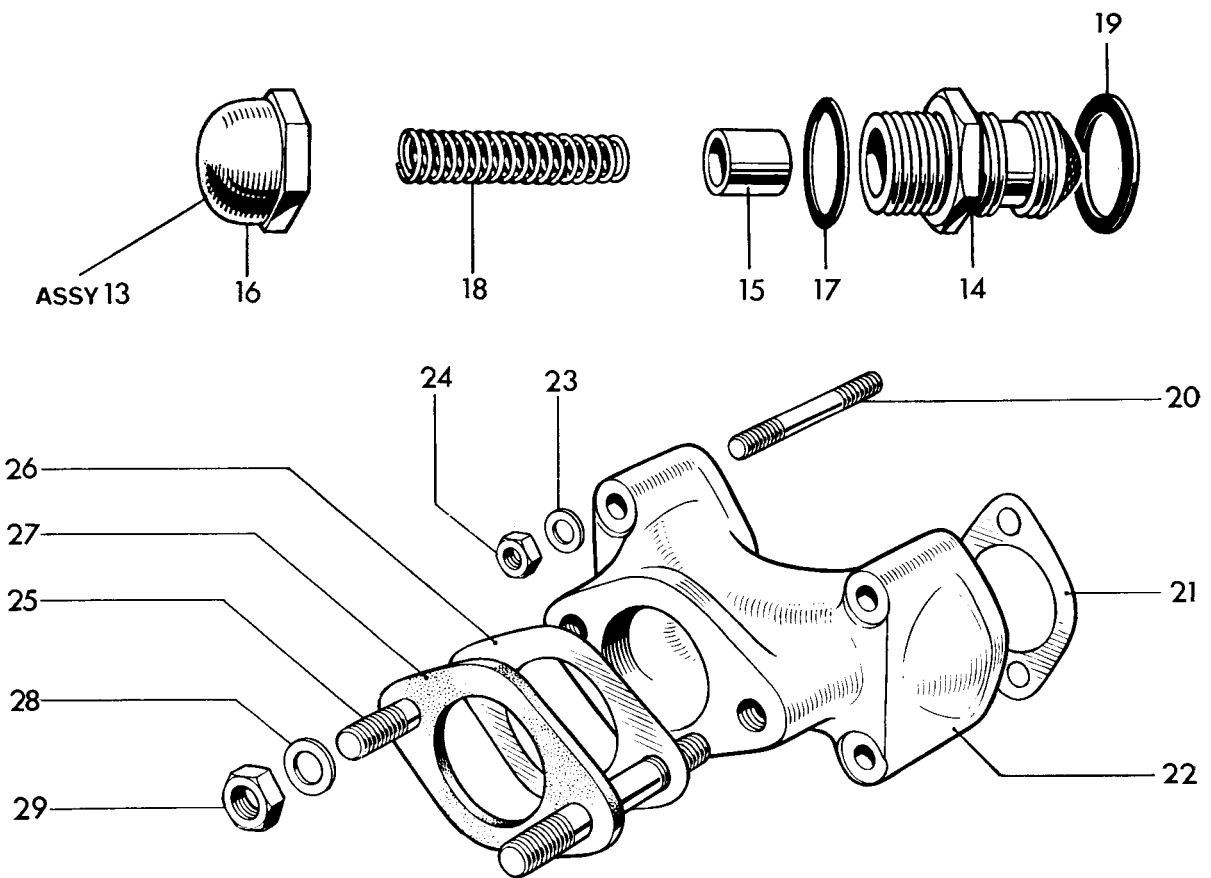
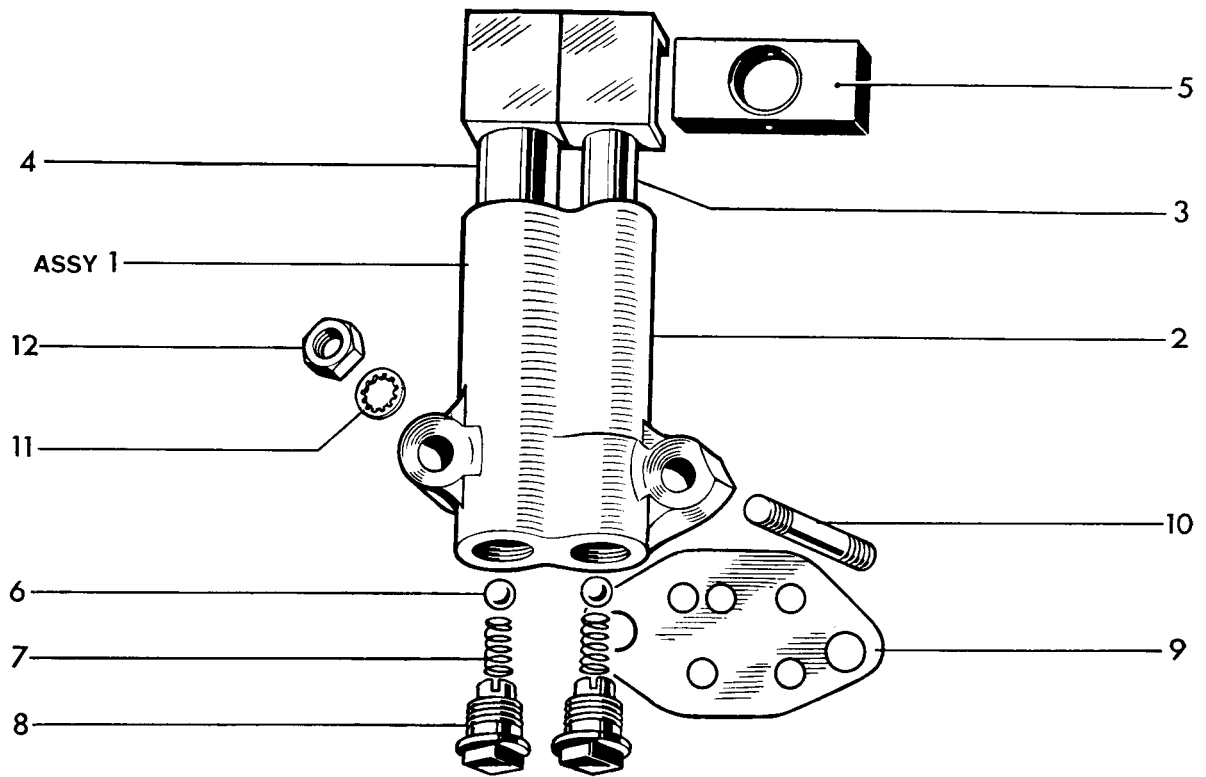

Fig. 3. OIL PUMP AND RELEASE VALVE AND MANIFOLD

Ref. No.	Part No.	DESCRIPTION	QUANTITY
<b>OIL PUMP AND RELEASE VALVE AND MANIFOLD</b>			
			6T      TR6      T120
1	E3878	OIL PUMP ... ..	1      1      1
2	E3731	Pump body... ..	1      1      1
3	GS153	Feed plunger ... ..	1      1      1
4	E1476	Scavenge plunger ... ..	1      1      1
5	E495	Drive block ... ..	1      1      1
6	S70-7	Valve ball ... ..	2      2      2
7	E403	Valve spring ... ..	2      2      2
8	E2360	Screwed plug ... ..	2      2      2
9	E3730	Joint washer ... ..	1      1      1
10	E3718	Oil pump stud (1- $\frac{5}{16}$ in. U.H.)	2      2      2
11	E3887	Serrated washer ... ..	2      2      2
12	E3732	Nut ... ..	2      2      2
13	E5896	OIL RELEASE VALVE	1      1      1
14	E2794	Valve body ... ..	1      1      1
15	GS251	Piston ... ..	1      1      1
16	E2304	Cap ... ..	1      1      1
17	GS254	Fibre washer ... ..	1      1      1
18	E6062	Main spring ... ..	1      1      1
19	E1670	Fibre washer ... ..	1      1      1
20	E2973	Stud (1- $\frac{5}{8}$ in. O.A.)	4      4      -
21	E3334	Joint washer ... ..	2      2      -
22	E3304	Inlet manifold ... ..	1      1      -
23	S25-13	Plain washer ... ..	4      4      -
24	W103	Nut ... ..	4      4      -
25	E2962	Stud (1- $\frac{7}{32}$ in. O.A.)	2      2      -
26	NA43A	Joint washer ... ..	1      1      -
27	E2968	Insulating block ... ..	1      1      -
28	S25-3	Plain washer ... ..	2      2      -
29	S1-51	Nut ... ..	2      2      -



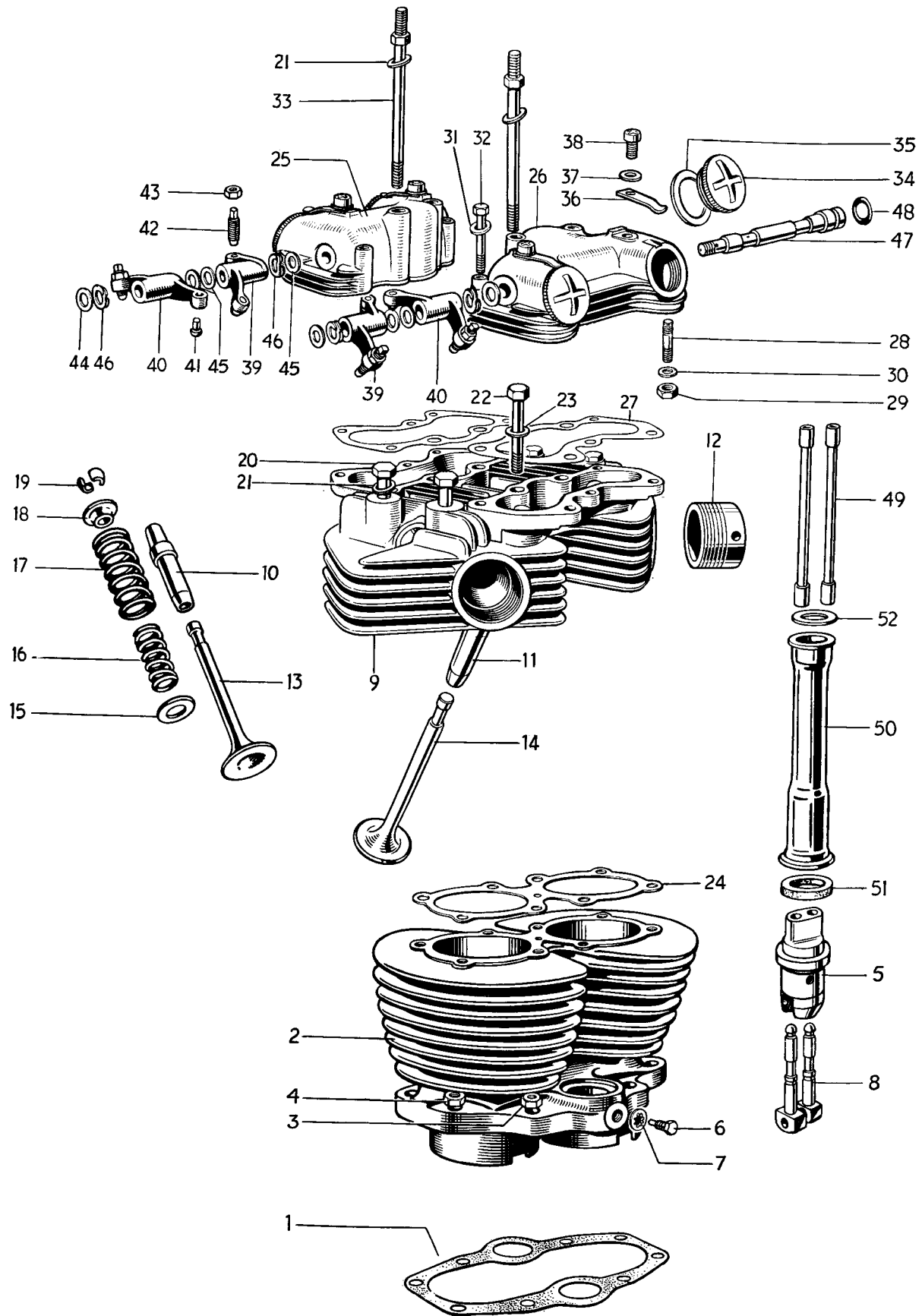

Fig. 4. CYLINDER BLOCK AND HEAD, 6T AND TR6

Ref. No.	Part No.	DESCRIPTION	QUANTITY	
		<b>CYLINDER BLOCK AND HEAD, 6T AND TR6</b>	<b>6T</b>	<b>TR6</b>
1	E2894	Cylinder base washer ... ..	1	1
2	E4546	Cylinder block ... ..	1	1
3	W76	Inner cylinder base nut ... ..	4	4
4	P0172A	Outer cylinder base nut ... ..	4	4
5	E1477	Tappet guide block ... ..	2	2
6	H200	Tappet block screw ... ..	2	2
7	E1612	Serrated washer ... ..	2	2
8	E3059	Tappet ... ..	4	4
9	E4552	CYLINDER HEAD c/w GUIDES ... ..	1	1
10	E2899	Inlet valve guide ... ..	2	2
11	E2900	Exhaust valve guide ... ..	2	2
12	E3583	Exhaust pipe adaptor ... ..	2	2
13	E3310	Inlet valve ... ..	2	2
14	E3927	Exhaust valve ... ..	2	2
15	E5008	Bottom cup ... ..	4	-
15	E1544	Bottom cup ... ..	-	4
16	E4221	Inner valve spring (red spot) ... ..	4	-
17	E4222	Outer valve spring (red spot) ... ..	4	-
16	E3001	Inner valve spring (white spot) ... ..	-	4
17	E3002	Outer valve spring (white spot) ... ..	-	4
18	E1543	Top collar ... ..	4	4
19	WE259A	Split cotter ... ..	8	8
20	E327	Cylinder head bolt (3 $\frac{3}{8}$ in. U.H.) ... ..	4	4
21	F2184	Plain washer ... ..	8	8
22	E4771	Bolt (3 in. U.H.) ... ..	1	1
23	S25-3	Plain washer ... ..	1	1
24	E4547	Cylinder head gasket ... ..	1	1
25	E4550	Inlet rocker box ... ..	1	1
26	E4551	Exhaust rocker box ... ..	1	1
27	E4549	Joint washer ... ..	2	2
28	E2980	Rocker box stud ( $1\frac{5}{8}$ in. O.A.) ... ..	6	6
29	F879	Rocker box nut... ..	6	6
30	E3302	Plain washer ... ..	6	6
31	E2982	Rocker box bolt (2 $\frac{5}{32}$ in. U.H.) ... ..	4	4
32	S25-13	Plain washer ... ..	4	4
33	E1596	Cylinder head bolt (for torque stay) ... ..	4	4
34	E4610	Inspection cap ... ..	4	4
35	E3751	Joint washer ... ..	4	4
36	E4609	Locking spring ... ..	4	4
37	WE170	Fibre washer ... ..	4	4
38	T1553	Screw ( $\frac{3}{8}$ in. U.H.) ... ..	4	4
39	E1457	ROCKER (right exhaust, left inlet) ... ..	2	2
40	E1458	ROCKER (left exhaust, right inlet) ... ..	2	2
41	E1483	Rocker ball pin ... ..	4	4
42	E1513	Rocker adjusting pin ... ..	4	4
43	E470	Adjuster lock nut ... ..	4	4
44	E1330	Thrust washer, $\frac{3}{8}$ in. ... ..	2	2
45	E1575	Thrust washer, $\frac{1}{2}$ in. ... ..	6	6
46	E1574	Spring washer ... ..	4	4
47	E1512	Rocker spindle ... ..	2	2
48	E3253	Sealing rubber ... ..	2	2
49	E2620	Push rod ... ..	4	4
50	E3646	Cover tube ... ..	2	2
51	E1496	Bottom joint washer ... ..	2	2
52	E3547	Top joint washer ... ..	2	2

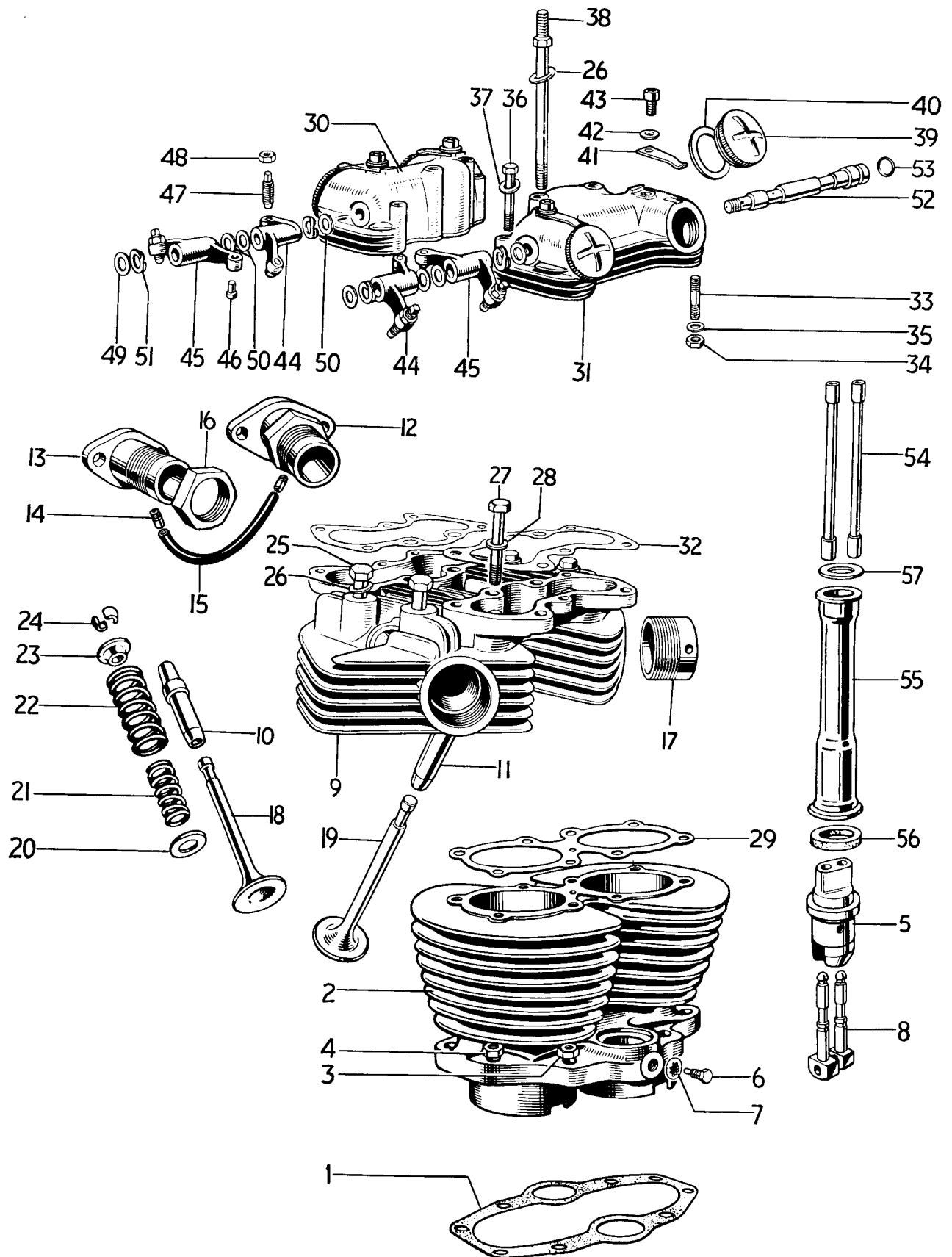

Fig. 5. CYLINDER BLOCK AND HEAD, T120

Ref. No.	Part No.	DESCRIPTION	QUANTITY
		<b>CYLINDER BLOCK AND HEAD, T120</b>	<b>T120</b>
1	E2894	Cylinder base washer ... ..	1
2	E4546	Cylinder block ... ..	1
3	W76	Inner cylinder base nut ... ..	4
4	P0172A	Outer cylinder base nut ... ..	4
5	E1477	Tappet guide block ... ..	2
6	H200	Tappet block screw ... ..	2
7	E1612	Serrated washer ... ..	2
8	E3059	Tappet ... ..	4
9	E5348	<b>CYLINDER HEAD c/w GUIDES</b> ... ..	1
10	E3827	Inlet valve guide ... ..	2
11	E3828	Exhaust valve guide ... ..	2
12	E5349	Carburetter adaptor, left ... ..	1
13	E5350	Carburetter adaptor, right ... ..	1
14	E4791	Connector ... ..	2
15	E4792	Balance pipe ... ..	1
16	E4608	Adaptor locking nut ... ..	2
17	E3583	Exhaust pipe adaptor ... ..	2
18	E4603	Inlet valve ... ..	2
19	E2904	Exhaust valve ... ..	2
10	E1544	Bottom cup ... ..	4
21	E3001	Inner valve spring ... ..	4
22	E3002	Outer valve spring ... ..	4
23	E1543	Top collar ... ..	4
24	WE259A	Split cotter ... ..	8
25	E327	Cylinder head bolt (3 $\frac{3}{8}$ in. U.H.) ... ..	4
26	F2184	Plain washer ... ..	8
27	E4771	Bolt (3 in. U.H.) ... ..	1
28	S25-3	Plain washer ... ..	1
29	E4547	Cylinder head gasket ... ..	1
30	E4550	Inlet rocker box ... ..	1
31	E4551	Exhaust rocker box ... ..	1
32	E4549	Joint washer ... ..	2
33	E2980	Rocker box stud ( $\frac{15}{16}$ in. O.A.) ... ..	6
34	F879	Nut ... ..	6
35	E3302	Plain washer ... ..	6
36	E2982	Rocker box bolt (2 $\frac{5}{32}$ in. U.H.) ... ..	4
37	S25-13	Plain washer ... ..	4
38	E1596	Cylinder head bolt (for torque stay) ... ..	4
39	E4610	Inspection cap ... ..	4
40	E3751	Joint washer ... ..	4
41	E4609	Locking spring ... ..	4
42	WE170	Fibre washer ... ..	4
43	T1553	Screw ( $\frac{3}{8}$ in. U.H.) ... ..	4
44	E1457	ROCKER (right exhaust, left inlet) ... ..	2
45	E1458	ROCKER (left exhaust, right inlet) ... ..	2
46	E1483	Rocker ball pin ... ..	4
47	E1513	Rocker adjusting pin ... ..	4
48	E470	Adjuster lock nut ... ..	4
49	E1330	Thrust washer, $\frac{3}{8}$ in. ... ..	2
50	E1575	Thrust washer, $\frac{1}{2}$ in. ... ..	6
51	E1574	Spring washer ... ..	4
52	E1512	Rocker spindle ... ..	2
53	E3253	Sealing rubber ... ..	4
54	E2620	Push rod ... ..	2
55	E3646	Cover tube ... ..	2
56	E1496	Bottom joint washer ... ..	2
57	E3547	Top joint washer ... ..	2

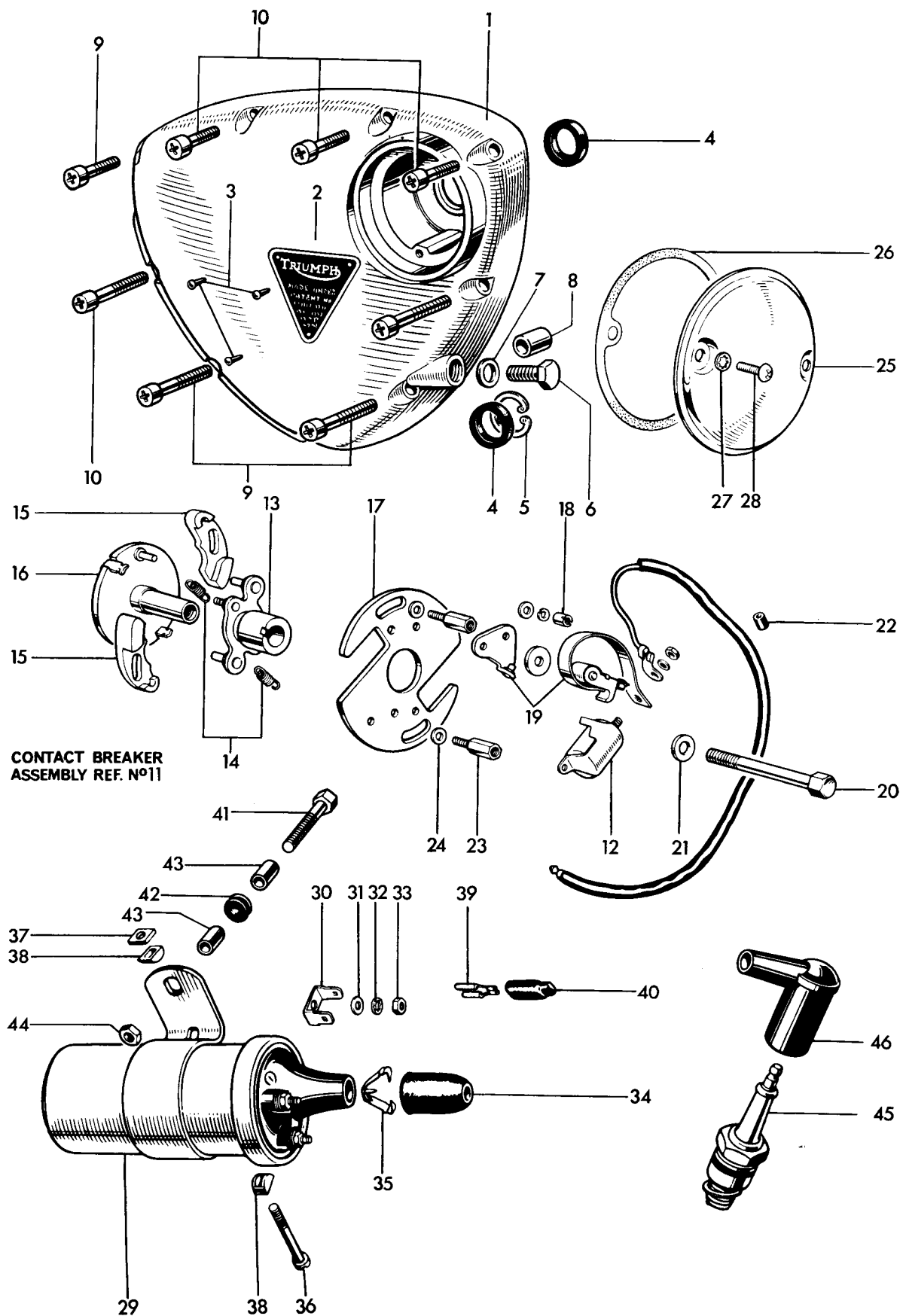

Fig. 6. TIMING COVER, CONTACT BREAKER AND COILS

Ref. No.	Part No.	DESCRIPTION	QUANTITY
----------	----------	-------------	----------

**TIMING COVER, CONTACT BREAKER AND COILS**

			6T	TR6	T120
1	E4567	Timing cover ... ..	1	1	1
2	E4016	Patent plate ... ..	1	1	1
3	D208-5	Hammer-drive screw ... ..	3	3	3
4	E4568	Oil seal ... ..	2	2	2
5	E4569	Circlip ... ..	1	1	1
6	E2615	Timing cover plug ... ..	1	1	1
7	E1335	Copper washer ... ..	1	1	1
8	T989	Hollow dowel ... ..	2	2	2
9	E3668	Screw (1 $\frac{5}{16}$ in. U.H.) ... ..	3	3	3
10	E3204	Screw (1 in. U.H.) ... ..	5	5	5
11	47605	CONTACT BREAKER, type 4CA ... ..	1	1	1
12	425377	Condenser ... ..	2	2	2
13	54441729	Cam... ..	1	1	1
14	54415642	Spring set ... ..	1	1	1
15	425379	Weight ... ..	2	2	2
16	54415751	Sleeve and action plate ... ..	1	1	1
17	425370	Base plate ... ..	1	1	1
18	169194	Slotted nut... ..	4	4	4
19	54415803	Contact set ... ..	2	2	2
20	E5451	Bolt (2 in. U.H.) ... ..	1	1	1
21	S25-43	Plain washer ... ..	1	1	1
22	E4707	Rubber grommet ... ..	1	1	1
23	E4747	Pillar bolt ... ..	2	2	2
24	E2351	Plain washer ... ..	2	2	2
25	E4571	Cover ... ..	1	1	1
26	E5049	Joint washer ... ..	1	1	1
27	GS299	Serrated washer ... ..	2	2	2
28	F4715	Screw ( $\frac{1}{2}$ in. U.H.) ... ..	2	2	2
29	45110	IGNITION COIL, type MA12 ... ..	2	-	-
29	45152	IGNITION COIL, type MA6 ... ..	-	2	2
30	54190108	Lucar terminal ... ..	4	4	4
31	131023	Plain washer (E2351) ... ..	4	4	4
32	188330	Serrated washer (GS299) ... ..	4	4	4
33	166043	Nut (F3799) ... ..	4	4	4
34	421554	Rubber grommet ... ..	2	2	2
35	421863	Cable clip ... ..	2	2	2
36	100104	Screw ... ..	2	2	2
37	169160	Square nut ... ..	2	2	2
38	422369	"D" washer ... ..	4	4	4
39	54942078	Lucar connector ... ..	4	4	4
40	54190042	Insulating cover... ..	4	4	4
41	F4744	Bolt (1 $\frac{5}{16}$ in. U.H.) ... ..	2	2	2
42	F5466	Rubber grommet ... ..	2	2	2
43	F4366	Distance piece ... ..	4	4	4
44	E3290	Self locking nut ... ..	2	2	2
45	—	Sparking plug (Champion N4) ... ..	2	2	2
46	D297	Plug cover and suppressor ... ..	2	2	2
46	D262	Plug cover ... ..	A	A	A

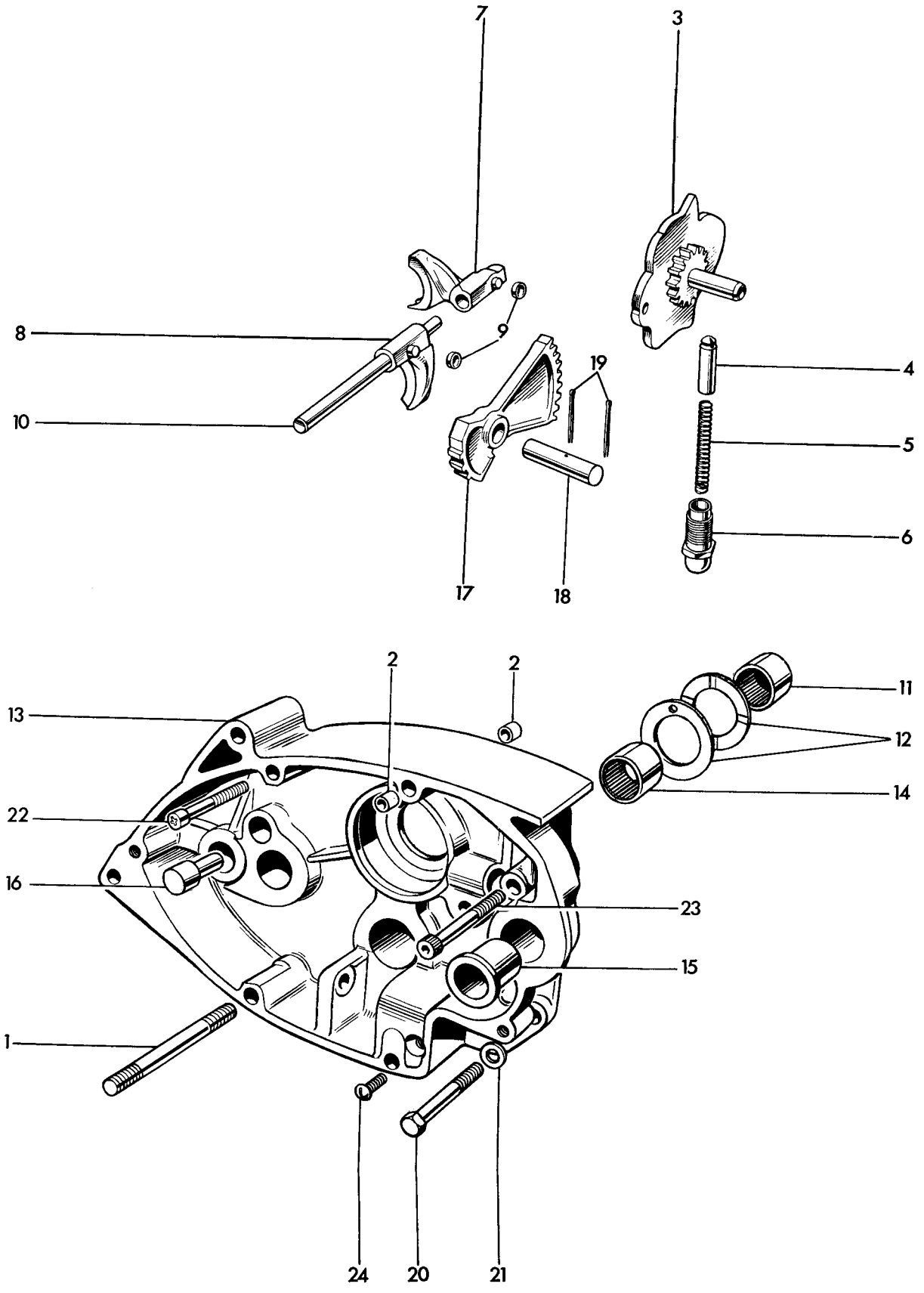

Fig. 7. GEARBOX INNER COVER AND SELECTORS

Ref. No.	Part No.	DESCRIPTION	QUANTITY		
<b>GEARBOX INNER COVER AND SELECTORS</b>					
			6T	TR6	T120
1	E4535	Stud (3 in. O.A.) ... ..	2	2	2
2	T989	Hollow dowel ... ..	4	4	4
3	T500	Gear selector camplate ... ..	1	1	1
4	T44	Camplate index plunger ... ..	1	1	1
5	T373	Index plunger spring ... ..	1	1	1
6	T372	Index plunger holder ... ..	1	1	1
7	T260B	Mainshaft selector fork ... ..	1	1	1
8	T913	Layshaft selector fork ... ..	1	1	1
9	NT261	Selector fork roller ... ..	2	2	2
10	T291	Selector fork rod ... ..	1	1	1
11	T1606	Layshaft bearing ... ..	1	1	1
12	T1607	Thrust washer ... ..	2	2	2
13	T1703	GEARBOX INNER COVER ... ..	1	1	1
14	T1614	Layshaft bearing ... ..	1	1	1
15	T412	Gearchange spindle bush... ..	1	1	1
16	T45	Kickstarter stop ... ..	1	1	1
17	T397	Camplate operating quadrant... ..	1	1	1
18	T1896	Quadrant spindle ... ..	1	1	1
19	$\frac{5}{64}$ in. x $1\frac{3}{8}$ in.	Split pin ... ..	2	2	2
20	T1778	Bolt ( $1\frac{1}{8}$ in. U.H.) ... ..	1	1	1
21	E3446	Plain washer ... ..	1	1	1
22	E3204	Screw (1 in. U.H.) ... ..	1	1	1
23	T1779	Socket screw ( $1\frac{3}{4}$ in. U.H.) ... ..	1	1	1
24	E3728	Countersunk screw ( $\frac{1}{2}$ in. U.H.) ... ..	1	1	1



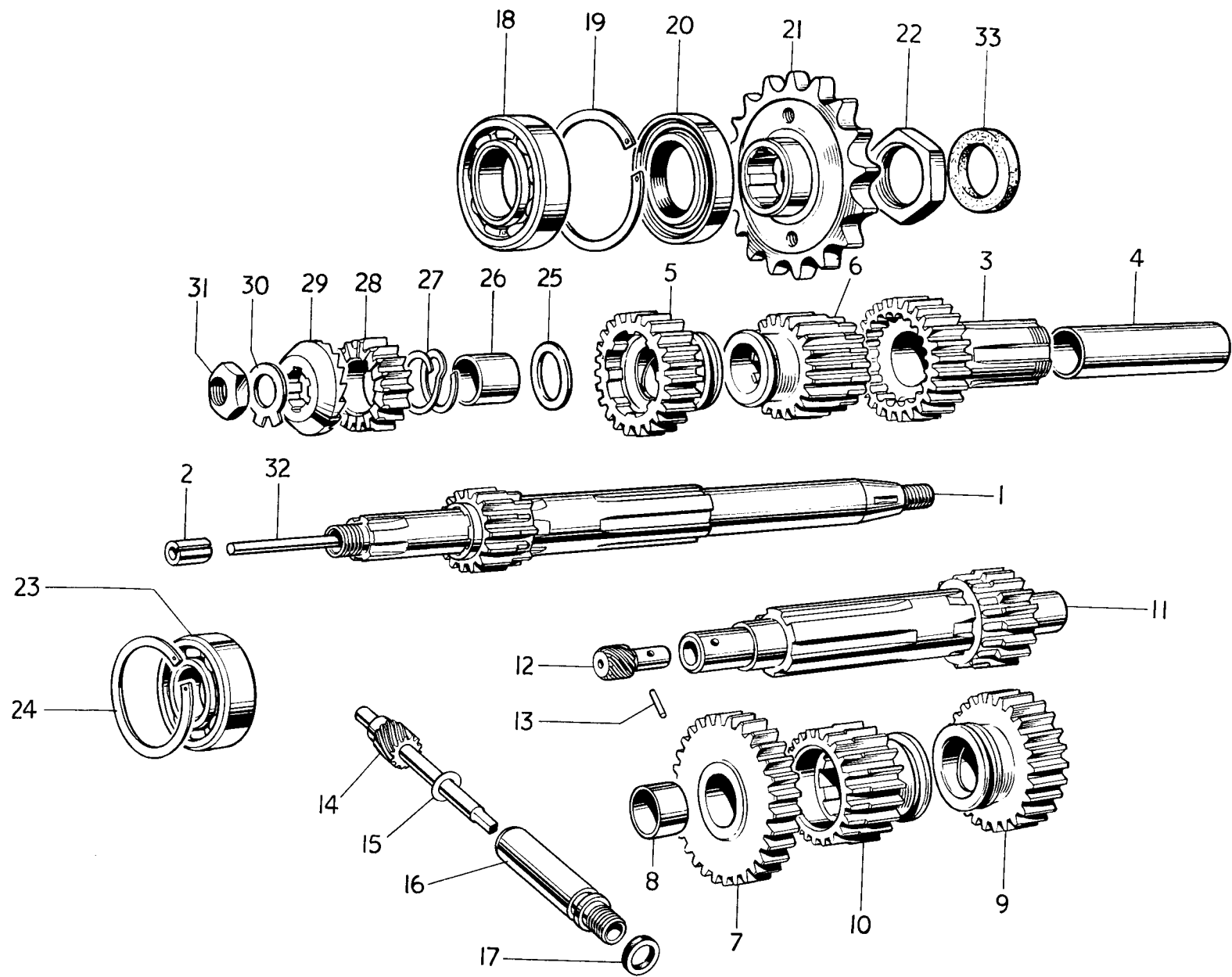

Fig. 8. GEARBOX SHAFTS AND GEARS

Ref. No.	Part No.	DESCRIPTION	QUANTITY		
<b>GEARBOX SHAFTS AND GEARS</b>					
			6T	TR6	T120
1	T914	MAINSHAFT c/w LOW GEAR (16T) ... ..	1	1	1
2	PT108B	Clutch rod bush ... ..	1	1	1
3	T1914	MAINSHAFT HIGH GEAR (26T) ... ..	1	1	1
4	T1370	High gear bush ... ..	1	1	1
5	T917	Mainshaft third gear (24T) ... ..	1	1	1
6	T916	Mainshaft second gear (20T) ... ..	1	1	1
7	T926	LAYSHAFT LOW GEAR (30T) ... ..	1	1	1
8	T928	Low gear bush ... ..	1	1	1
9	T1065	Layshaft second gear (26T) ... ..	1	1	1
10	T930	Layshaft third gear (22T) ... ..	1	1	1
11	T1843	Layshaft c/w high gear (20T) ... ..	1	1	1
12	T1744	Speedometer pinion, solo (10T) ... ..	1	1	1
12	T1747	Speedometer pinion, sidecar (9T) ... ..	A	A	A
13	T925	Securing pin ... ..	1	1	1
14	T1745	Speedometer gear, solo (15T) ... ..	1	1	1
14	T1748	Speedometer gear, sidecar (15T) ... ..	A	A	A
15	T825	Thrust washer ... ..	1	1	1
16	T933	Speedometer drive bush ... ..	1	1	1
17	T948	Rubber sealing ring ... ..	1	1	1
18	T448	High gear bearing ... ..	1	1	1
19	T489	Circlip ... ..	1	1	1
20	T946	Oil seal ... ..	1	1	1
21	T1919	Gearbox sprocket (20 teeth) solo ... ..	1	-	-
21	T1918	Gearbox sprocket (19 teeth) solo ... ..	-	1	1
21	T1917	Gearbox sprocket (18 teeth) side-car ... ..	A	-	-
21	T1916	Gearbox sprocket (17 teeth) side-car ... ..	-	A	A
22	T440	Gearbox sprocket nut ... ..	1	1	1
23	S35-7	Mainshaft bearing ... ..	1	1	1
24	T280	Circlip ... ..	1	1	1
25	T1962	Plain washer ... ..	1	1	1
26	T1963	Pinion sleeve ... ..	1	1	1
27	T1250	Pinion spring ... ..	1	1	1
28	T730	Kickstarter pinion ... ..	1	1	1
29	T731	Kickstarter ratchet ... ..	1	1	1
20	T732	Tab washer ... ..	1	1	1
31	NT297	Nut ... ..	1	1	1
32	T1736	Clutch operating rod ... ..	1	1	1
33	T1979	Felt washer ... ..	1	1	1

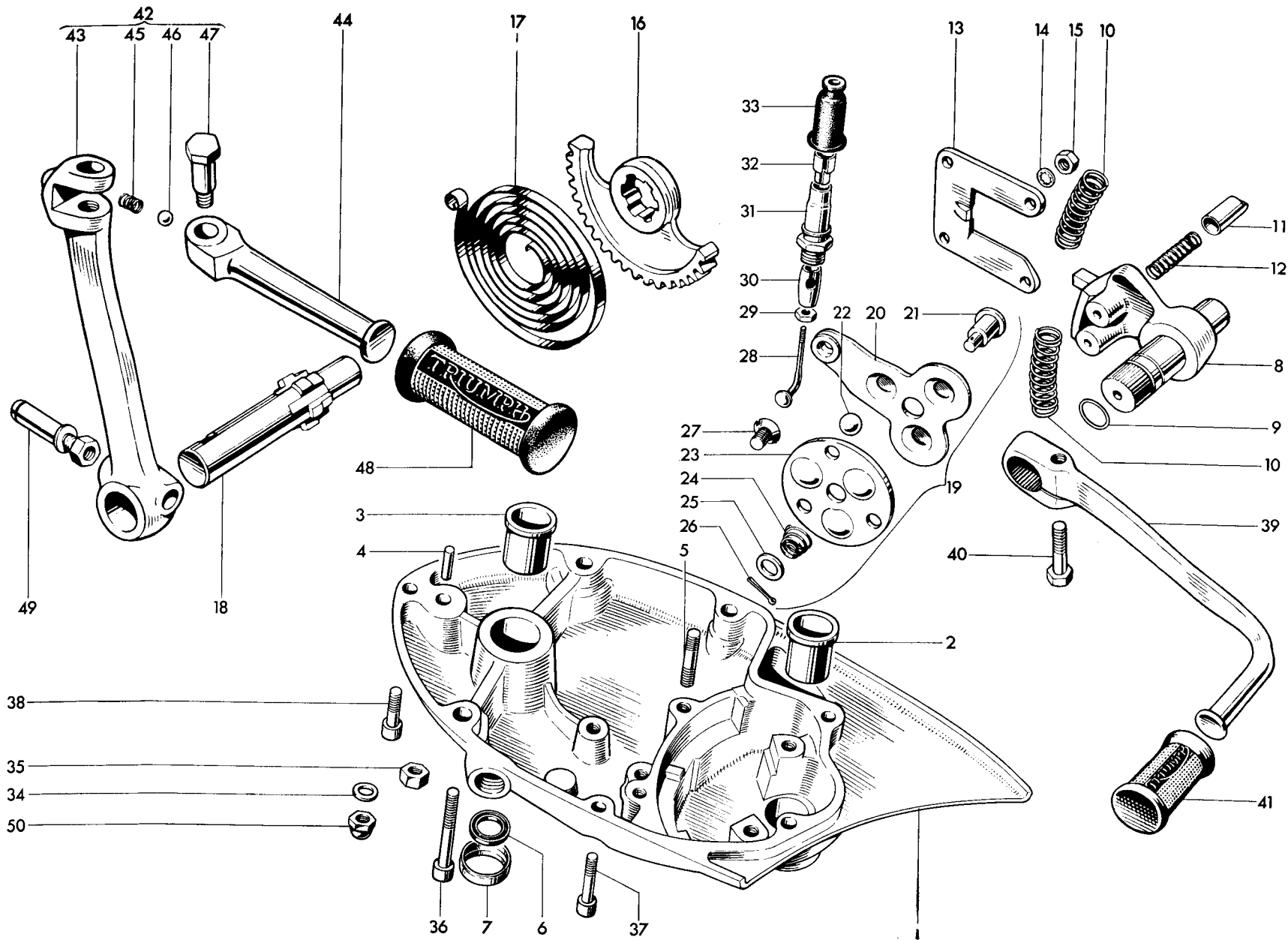

Fig. 9. GEARBOX OUTER COVER

Ref. No.	Part No.	DESCRIPTION	QUANTITY		
<b>GEARBOX OUTER COVER</b>					
1	T1986	GEARBOX OUTER COVER	6T	TR6	T120
2	T57	Gearchange spindle bush...	1	1	1
3	T23	Kickstarter spindle bush	1	1	1
4	T47	Kickstarter spring anchor pin	1	1	1
5	T454	Guide plate stud ( $\frac{7}{8}$ in. O.A.)	4	4	4
6	T1956	Oil seal	1	1	1
7	T1955	Oil seal housing	1	1	1
8	T408/9	Gearchange quadrant	1	1	1
9	E3309	Rubber "O" ring	1	1	1
10	T404	Quadrant return spring	2	2	2
11	T406	Gearchange quadrant plunger	2	2	2
12	T405	Plunger spring	2	2	2
13	T407	Guide plate	1	1	1
14	E1612	Serrated washer	4	4	4
15	F879	Nut	4	4	4
16	T25A	Kickstarter quadrant	1	1	1
17	T31	Kickstarter return spring	1	1	1
18	T24A	Kickstarter axle	1	1	1
19	T1707	CLUTCH LEVER ASSEMBLY	1	1	1
20	T1708	Clutch lever	1	1	1
21	T1710	Lever shaft	1	1	1
22	T1771	Ball, $\frac{3}{8}$ in. diam.	3	3	3
23	T1711	Thrust plate	1	1	1
24	T1712	Return spring	1	1	1
25	GS127	Plain washer	1	1	1
26	$\frac{5}{16}$ in. x $\frac{1}{2}$ in.	Split pin	1	1	1
27	T1713	Countersunk screw ( $\frac{3}{8}$ in. O.A.)	2	2	2
28	T1714	Spoke	1	1	1
29	T1937	Locknut	1	1	1
30	T1946	Connector	1	1	1
31	T1644	Abutment	1	1	1
32	T1645	Adaptor	1	1	1
33	T1646	Rubber cover	1	1	1
34	S25-3	Plain washer	2	2	2
35	S1-51	Nut	1	1	1
36	E3802	Screw ( $2\frac{3}{4}$ in. U.H.)	2	2	2
37	E3668	Screw ( $1\frac{5}{16}$ in. U.H.)	2	2	2
38	E3204	Screw (1 in. U.H.)	1	1	1
39	T1750	Gearchange pedal	1	1	1
40	W932	Bolt (1 in. U.H.)	1	1	1
41	T449	Pedal rubber	1	1	1
42	T1938	FOLDING KICKSTARTER	1	1	1
43	T1939	Kickstarter lever	1	1	1
44	T1272	Kickstarter pedal	1	1	1
45	T1167	Pedal locating spring	1	1	1
46	S70-3	Steel ball, $\frac{1}{4}$ in. diam.	1	1	1
47	T1273	Pedal bolt	1	1	1
48	F1814	Pedal rubber	1	1	1
49	T1222	Cotter pin c/w nut and washer	1	1	1
50	H1531	Domed nut	1	1	1

CLUTCH ASSEMBLY № 1

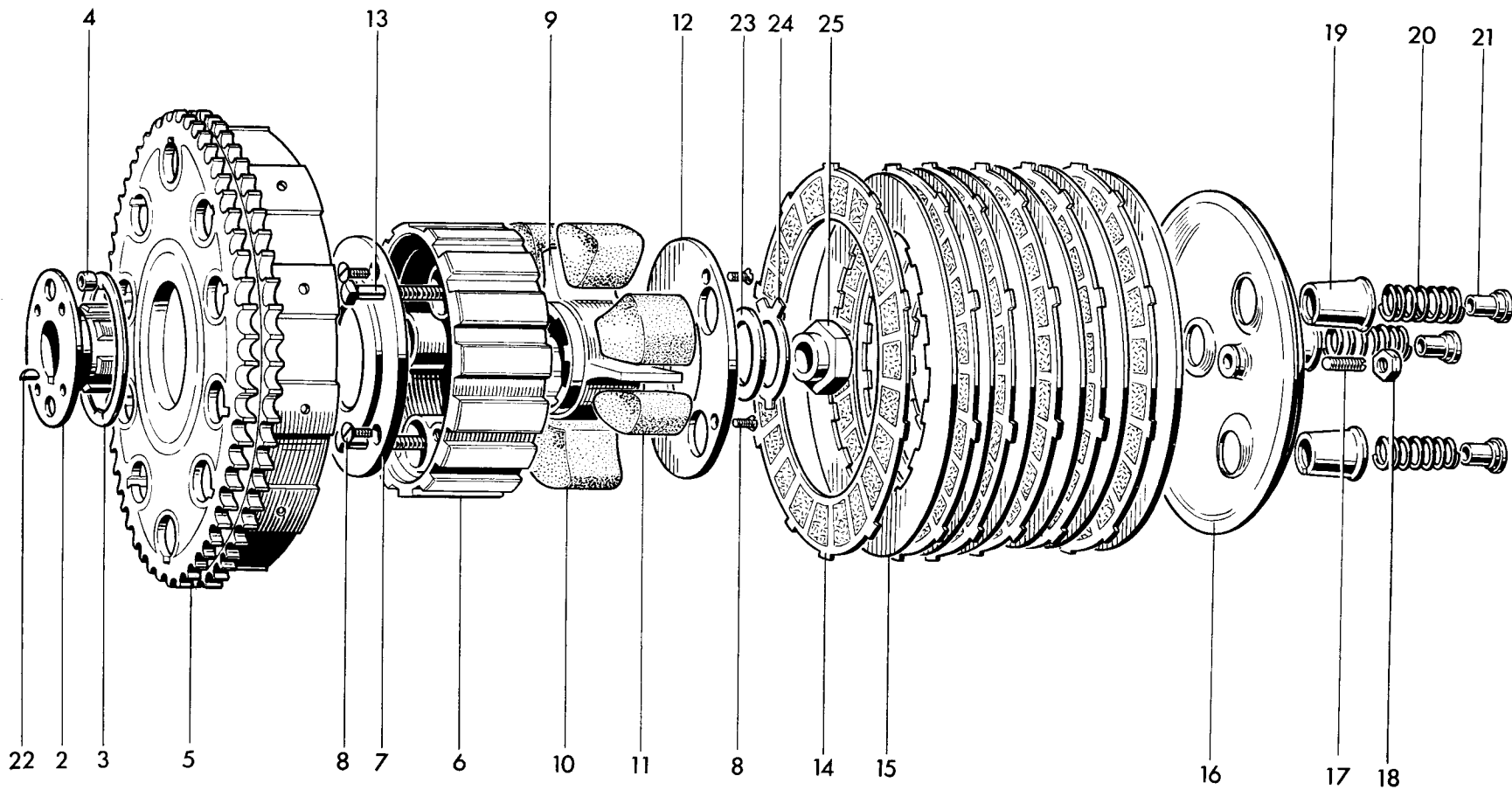

Fig. 10. CLUTCH

Ref. No.	Part No.	DESCRIPTION	QUANTITY		
<b>CLUTCH</b>					
			6T	TR6	T120
1	T1928	CLUTCH COMPLETE ... ..	1	1	1
2	T1734	Hub ... ..	1	1	1
3	T1735	Thrust washer ... ..	1	1	1
4	T394	Roller ... ..	20	20	20
5	T1570	Sprocket and housing (58 teeth Duplex) ... ..	1	1	1
6	T1719	Centre ... ..	1	1	1
7	T1720	Inner plate ... ..	1	1	1
8	T1040	Countersunk screw (0.417 in. U.H.) ... ..	6	6	6
9	T1721	Shock absorber spider ... ..	1	1	1
10	T1722	Drive rubber (large) ... ..	3	3	3
11	T1723	Rebound rubber (small) ... ..	3	3	3
12	T1724	Outer plate ... ..	1	1	1
13	T423A	Screwed pin ( $1\frac{27}{32}$ in. U.H.) ... ..	3	3	3
14	T1362	Driving plate (bonded) ... ..	6	6	6
15	T1363	Driven plate ... ..	6	6	6
16	T1929	Pressure plate ... ..	1	1	1
17	T1256	Adjuster pin ... ..	1	1	1
18	GS662	Nut ... ..	1	1	1
19	T1931	Spring cup ... ..	3	3	3
20	T1830	Spring ... ..	3	3	3
21	T427	Brass nut ... ..	3	3	3
22	S66-1	Key ... ..	1	1	1
23	T1045	Cupped washer ... ..	1	1	1
24	T1046	Tab washer ... ..	1	1	1
25	T1047	Clutch securing nut ... ..	1	1	1

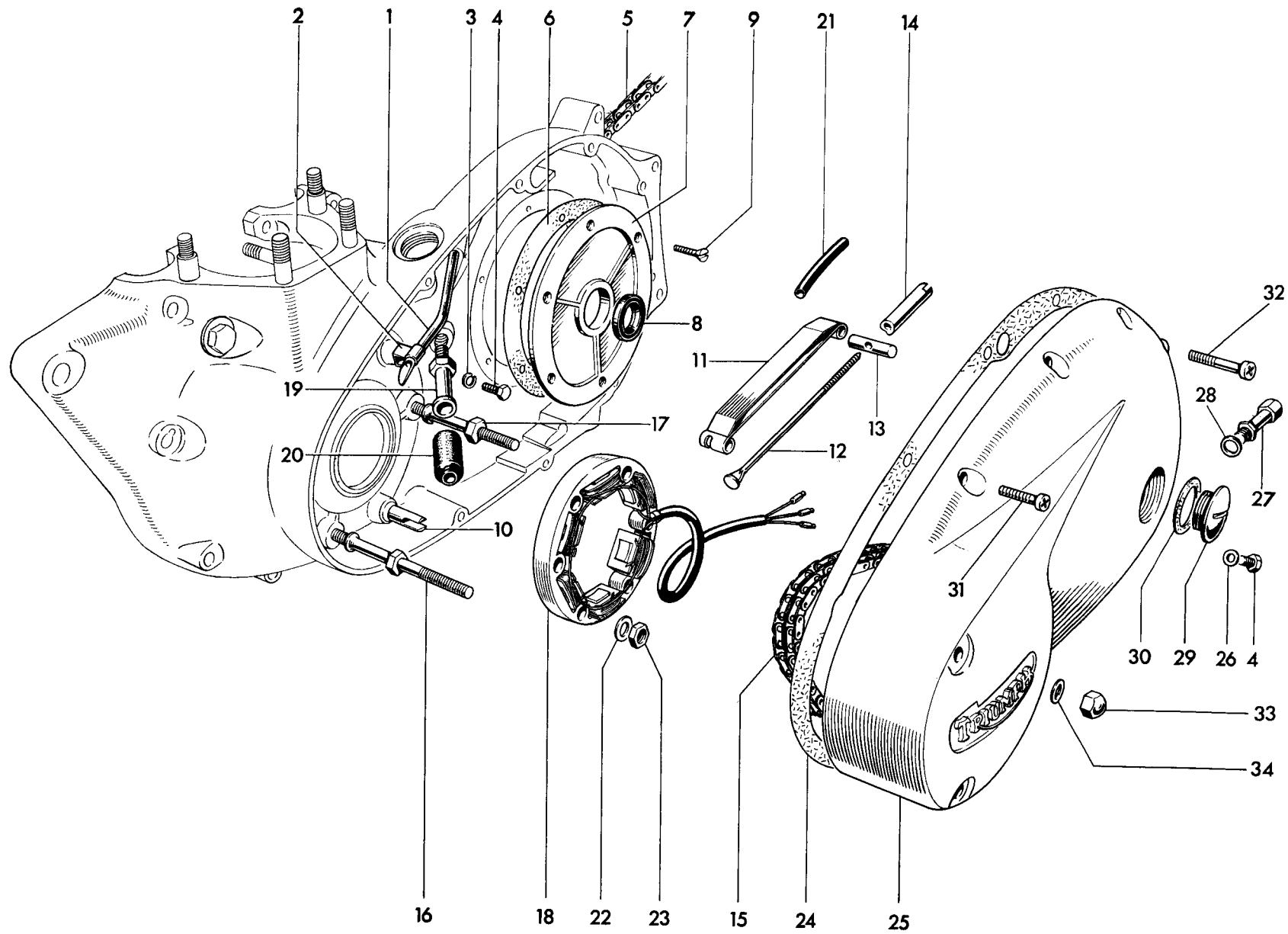

Fig. 11. CHAINCASE AND CHAINS

Ref. No.	Part No.	DESCRIPTION	QUANTITY		
----------	----------	-------------	----------	--	--

### CHAINCASE AND CHAINS

			6T	TR6	T120
1	E4704	Primary chain oiler tube ... ..	1	1	1
2	E4705	Clip ... ..	1	1	1
3	S26-2	Spring washer ... ..	1	1	1
4	DS57	Bolt ( $\frac{7}{16}$ in. U.H.) ... ..	2	2	2
5	D481	Rear chain, $\frac{5}{8}$ in. x $\frac{3}{8}$ in. x 103 links ... ..	1	1	1
6	E3832	Joint washer ... ..	1	1	1
7	E4577	Cover plate ... ..	1	1	1
8	E4578	Oil seal ... ..	1	1	1
9	E3821	Countersunk screw ( $\frac{5}{16}$ in. U.H.) ... ..	6	6	6
10	E4147	Chain tensioner abutment ... ..	1	1	1
11	E4149	Chain tensioner blade ... ..	1	1	1
12	E4152	Tie rod ... ..	1	1	1
13	E4145	Trunnion ... ..	1	1	1
14	E4153	Adjuster sleeve nut ... ..	1	1	1
15	D477	Primary chain, $\frac{3}{8}$ in. Duplex x 84 links ... ..	1	1	1
16	E4536	Stator stud ... ..	2	2	2
17	E4537	Stator stud ... ..	1	1	1
18	47162	Stator, RM 19 ... ..	1	1	1
19	E5872	Sleeve nut ... ..	1	1	1
20	E4144	Rubber grommet ... ..	1	1	1
21	E5449	Plastic sleeve ... ..	1	1	1
22	S25-3	Plain washer ... ..	3	3	3
23	E5324	Self-locking nut ... ..	3	3	3
24	T1770	Joint washer ... ..	1	1	1
25	T1727	Chaincase ... ..	1	1	1
26	E2441	Copper washer ... ..	1	1	1
27	E4922	Drain and adjuster plug ... ..	1	1	1
28	T1738	Fibre washer ... ..	1	1	1
29	E732	Filler plug ... ..	1	1	1
30	NE507	Fibre washer ... ..	1	1	1
31	E4806	Screw ( $\frac{3}{8}$ in. U.H.) ... ..	2	2	2
32	E3204	Screw (1 in. U.H.) ... ..	6	6	6
33	H1531	Domed nut ... ..	2	2	2
34	F1880	Copper washer ... ..	2	2	2



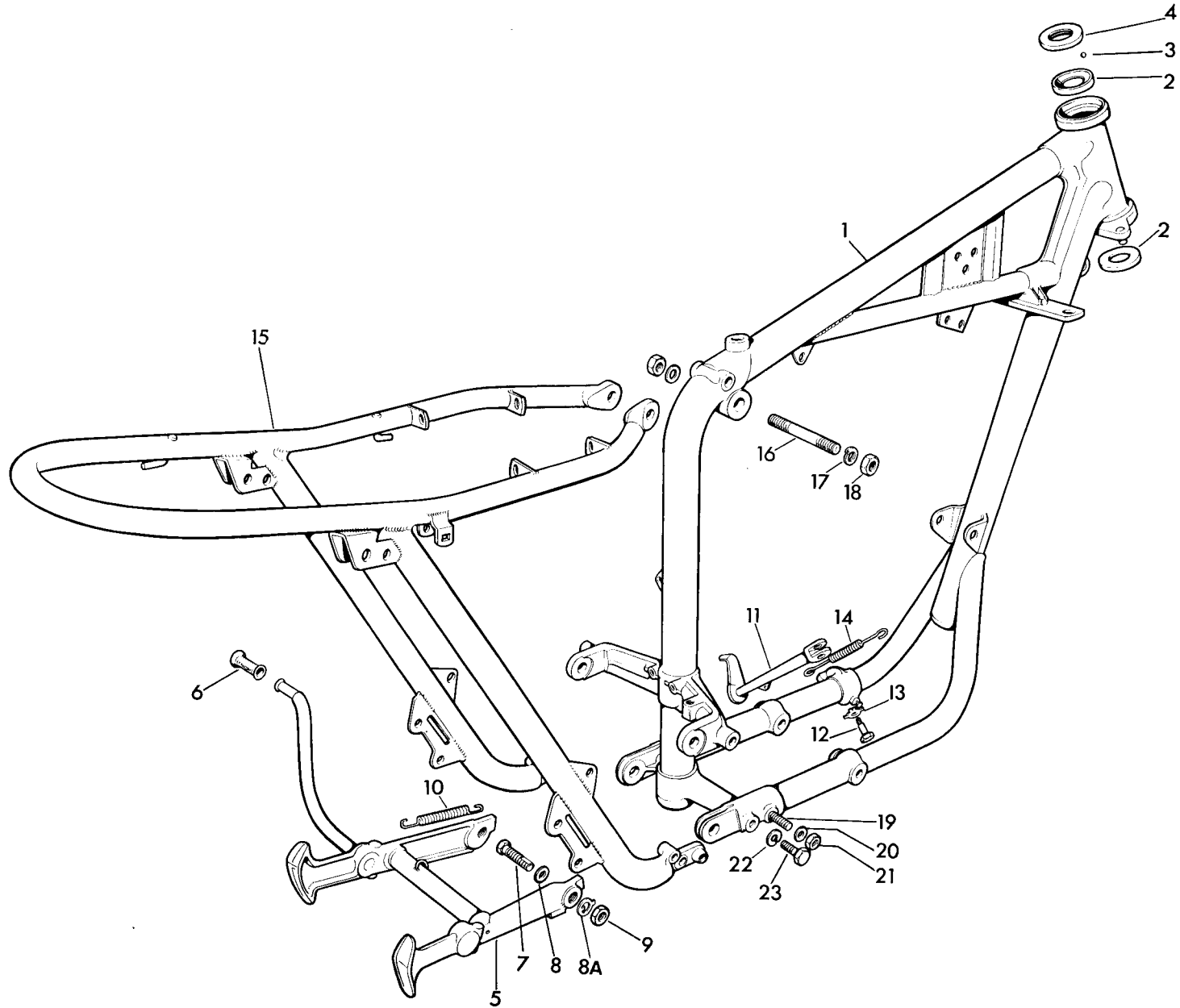

Fig. 12. FRAME

Ref. No.	Part No.	DESCRIPTION	QUANTITY		
<b>FRAME</b>					
			6T	TR6	T120
1	F6442	Front frame ... ..	1	1	1
2	H111	Steering race cup ... ..	2	2	2
3	S70-3	Steel ball ( $\frac{1}{4}$ in. diam.) ... ..	40	40	40
4	H1018	Top cone and dust cover ... ..	1	1	1
5	F5932	Centre stand ... ..	1	1	1
6	T449	Pedal rubber ... ..	1	1	1
7	F5678	Pivot bolt ... ..	2	2	2
8	F5679	Plain washer ... ..	2	2	2
8A	F4484	Tab washer ... ..	2	2	2
9	F2725	Nut ... ..	2	2	2
10	F4671	Return spring ... ..	1	1	1
11	F4388	PROP STAND COMPLETE (3.50 rear tyre) ... ..	1	-	1
11	F4712	PROP STAND COMPLETE (4.00 rear tyre) ... ..	-	1	-
12	F3097	Pivot bolt ... ..	1	1	1
13	F3096	Tab washer ... ..	1	1	1
14	F2610	Return spring ... ..	1	1	1
15	F6443	Rear frame ... ..	1	1	1
16	F4510	Stud ( $4\frac{3}{8}$ in. O.A.) (when panels are fitted) ... ..	1	-	-
16	F2842	Stud ( $3\frac{7}{8}$ in. O.A.) ... ..	-	1	1
17	S26-1	Spring washer ... ..	2	2	2
18	S1-52	Nut ... ..	2	2	2
19	F4369	Bolt ( $2\frac{1}{16}$ in. U.H.) ... ..	2	2	2
20	F4370	Plain washer ... ..	2	2	2
21	DS47	Nut ... ..	2	2	2
22	PCW73A	Spring washer ... ..	2	2	2
23	F5605	Bolt ( $1\frac{3}{16}$ in. U.H.) ... ..	2	2	2



Ref. No.	Part No.	DESCRIPTION	6T	TR6	T120
<b>SWINGING FORK AND SUSPENSION UNITS</b>					
1	F5302	SWINGING FORK ... ..	1	1	1
2	F6042	Pivot bush ... ..	2	2	2
3	NW100	Grease nipple ... ..	1	1	1
4	WE170	Fibre washer ... ..	1	1	1
5	F5312	Sleeve ... ..	2	2	2
6	F5313	Distance tube ... ..	1	1	1
7	F5311	End plate ... ..	2	2	2
8	F6150	Bolt (8 $\frac{5}{8}$ in. U.H.) ... ..	1	1	1
9	F5944	Tab washer ... ..	1	1	1
10	NT297	Nut ... ..	1	1	1
11	F3774	Brake torque stay ... ..	1	1	1
12	F5315	Bolt (2 $\frac{7}{2}$ in. U.H.) ... ..	1	1	1
13	PCW73A	Spring washer ... ..	2	2	2
14	DS47	Nut ... ..	2	2	2
15	†64054506	SUSPENSION UNIT ... ..	2	-	2
15	†64054164	SUSPENSION UNIT ... ..	-	2	-
16	9054/316A	Bonded bush ... ..	4	4	4
17	9054/171	Spring retainer ... ..	4	4	4
18	9054/151	Outer dirt shield ... ..	2	2	2
19	9054/47	Inner dirt shield ... ..	2	2	2
20	SA253/5	Spring, 145 lbs. Blue/Yellow ... ..	2	-	2
20	9054/280	Spring, 100 lbs. Green/Green ... ..	-	2	-
21	E2113	Unit fixing bolt (1 $\frac{5}{16}$ in. U.H.) ... ..	2	4	4
22	S25-2	Plain washer ... ..	2	2	2
23	S26-1	Spring washer ... ..	2	2	2
24	GS308	Plain washer ... ..	-	2	2
25	P0172A	Nut ... ..	4	4	4
26	F6257	Chainguard ... ..	1	1	1
27	F5536	Grommet ... ..	1	1	1
28	F4135	Pivot bolt ... ..	1	1	1
29	F2277	Spring washer ... ..	1	1	1
30	S25-13	Plain washer ... ..	2	2	2
31	E5269	Self-locking nut ... ..	1	1	1
32	F4136	Stepped bolt ... ..	1	1	1
33	S25-3	Plain washer ... ..	1	1	1
34	S1-51	Nut ... ..	1	1	1
35	F3808	Clip ... ..	1	1	1
36	F5741	Distance piece ... ..	1	1	1
37	E3872	Bolt (1 $\frac{1}{2}$ in. U.H.) ... ..	1	1	1
38	S26-2	Spring washer ... ..	1	1	1
39	F3597	Brake operating rod ... ..	1	1	1
40	$\frac{1}{16}$ in. x $\frac{3}{8}$ in.	Split pin ... ..	1	1	1
41	W11	Pivot pin... ..	1	1	1
42	F6070	Adjuster nut ... ..	1	1	1
43	31437	Stop lamp switch, type 22B ... ..	1	1	1
44	T1076	Screw ( $\frac{3}{8}$ in. U.H.) ... ..	3	3	3
45	F4717	Self locking nut ... ..	5	5	5
46	F5412	Switch lever ... ..	1	1	1
47	F5413	"D" washer ... ..	1	1	1
48	315738	Spring (F.3158) ... ..	1	1	1
49	F6451	Bolt ... ..	2	-	-
	†SB4/275	Sidecar suspension unit ... ..		as required	

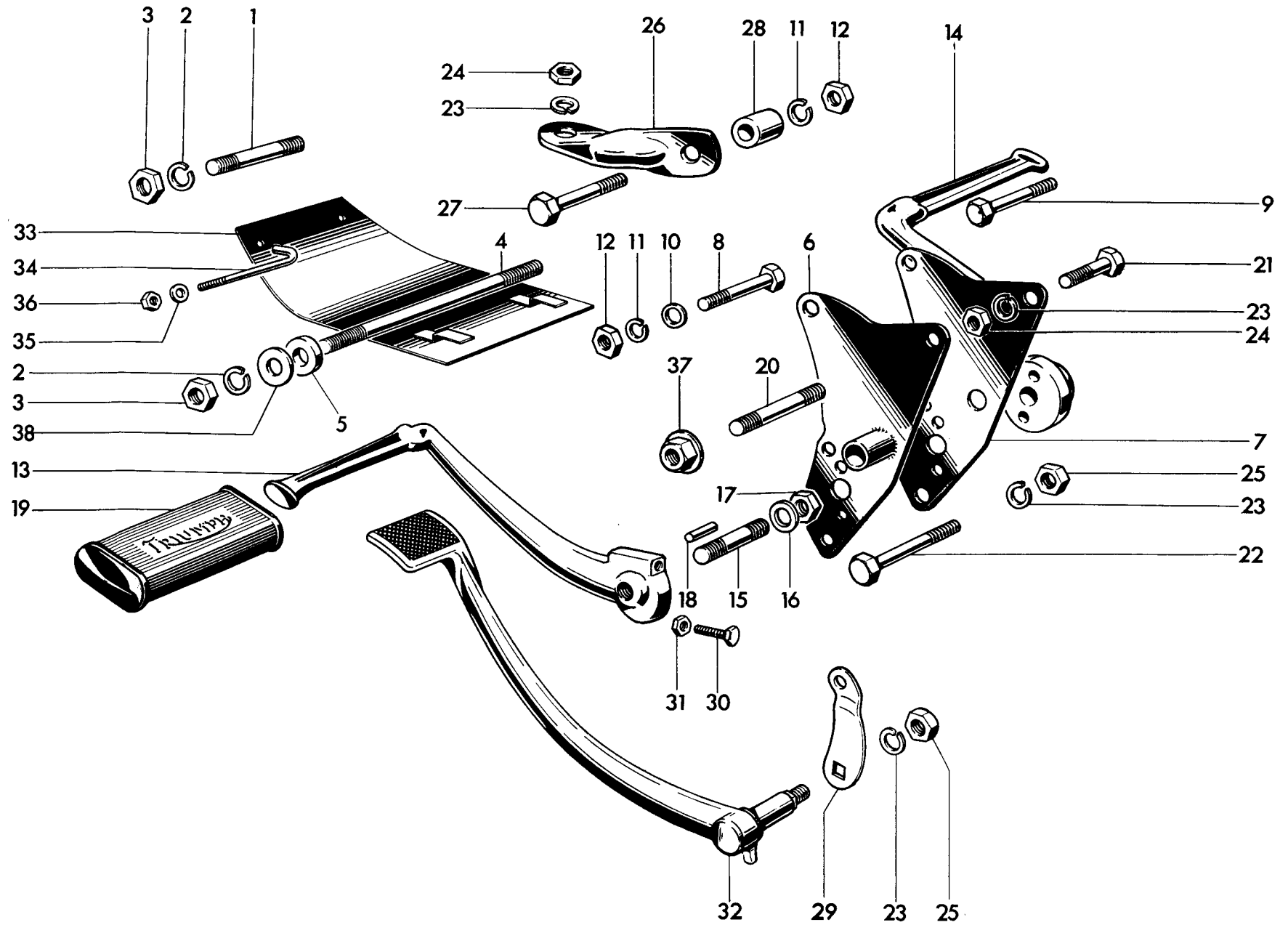

Fig. 14. ENGINE UNIT FITTINGS AND FOOTRESTS

Ref. No.	Part No.	DESCRIPTION	QUANTITY		
----------	----------	-------------	----------	--	--

**ENGINE UNIT FITTINGS AND FOOTRESTS**

			6T	TR6	T120
1	F5469	Stud (3 $\frac{5}{16}$ in. O.A.) ... ..	1	1	1
2	PCW73A	Spring washer ... ..	4	4	4
3	DS47	Nut ... ..	4	4	4
4	F6498	Stud (7 $\frac{7}{8}$ in. O.A.) ... ..	1	1	1
5	F5532	Distance piece ... ..	2	2	2
6	F6066	Left rear engine plate ... ..	1	1	1
7	F5908	Right rear engine plate ... ..	1	1	1
8	E4165	Bolt (1 $\frac{11}{16}$ in. U.H.) ... ..	2	2	2
9	F5316	Bolt (1 $\frac{7}{8}$ in. U.H.) ... ..	2	2	2
10	S25-3	Plain washer ... ..	4	4	4
11	S26-3	Spring washer ... ..	6	6	6
12	SI-51	Nut ... ..	6	6	6
13	F6069	Left footrest ... ..	1	1	1
14	F5910	Right footrest ... ..	1	1	1
15	F5942	Stud (1 $\frac{9}{16}$ in. O.A.) ... ..	2	2	2
16	S25-6	Plain washer ... ..	2	2	2
17	S4-13	Nut ... ..	2	2	2
18	F5943	Peg ... ..	4	4	4
19	NF704	Footrest rubber ... ..	2	2	2
20	F5351	Stud (1 $\frac{29}{32}$ in. O.A.) ... ..	2	-	-
20	E3114	Stud (1 $\frac{3}{16}$ in. O.A.) ... ..	-	2	2
21	F1031	Bolt (1 $\frac{5}{8}$ in. U.H.) ... ..	-	1	1
21	H426	Bolt (2 $\frac{3}{32}$ in. U.H.) ... ..	2	1	1
22	F3248	Bolt (1 $\frac{19}{32}$ in. U.H.) ... ..	2	2	2
23	S26-1	Spring washer ... ..	9	9	9
24	S1-52	Nut ... ..	7	7	7
25	P0172A	Nut ... ..	3	3	3
26	E4778	Engine torque stay ... ..	4	4	4
27	F3805	Bolt (1 $\frac{5}{16}$ in. U.H.) ... ..	2	2	2
28	F3069	Distance piece ... ..	4	4	4
29	F6064	Brake pedal lever ... ..	1	1	1
30	F1149	Bolt (1 $\frac{5}{8}$ in. U.H.) ... ..	1	1	1
31	F879	Nut ... ..	1	1	1
32	F6449	Brake pedal ... ..	1	1	1
33	F5472	Crankcase undershield... ..	-	1	-
34	F5788	Hook bolt ... ..	-	2	-
35	S25-1	Plain washer ... ..	-	2	-
36	F879	Nut ... ..	-	2	-
37	F3771	Nut ... ..	2	2	2
38	F4370	Plain washer ... ..	2	2	2

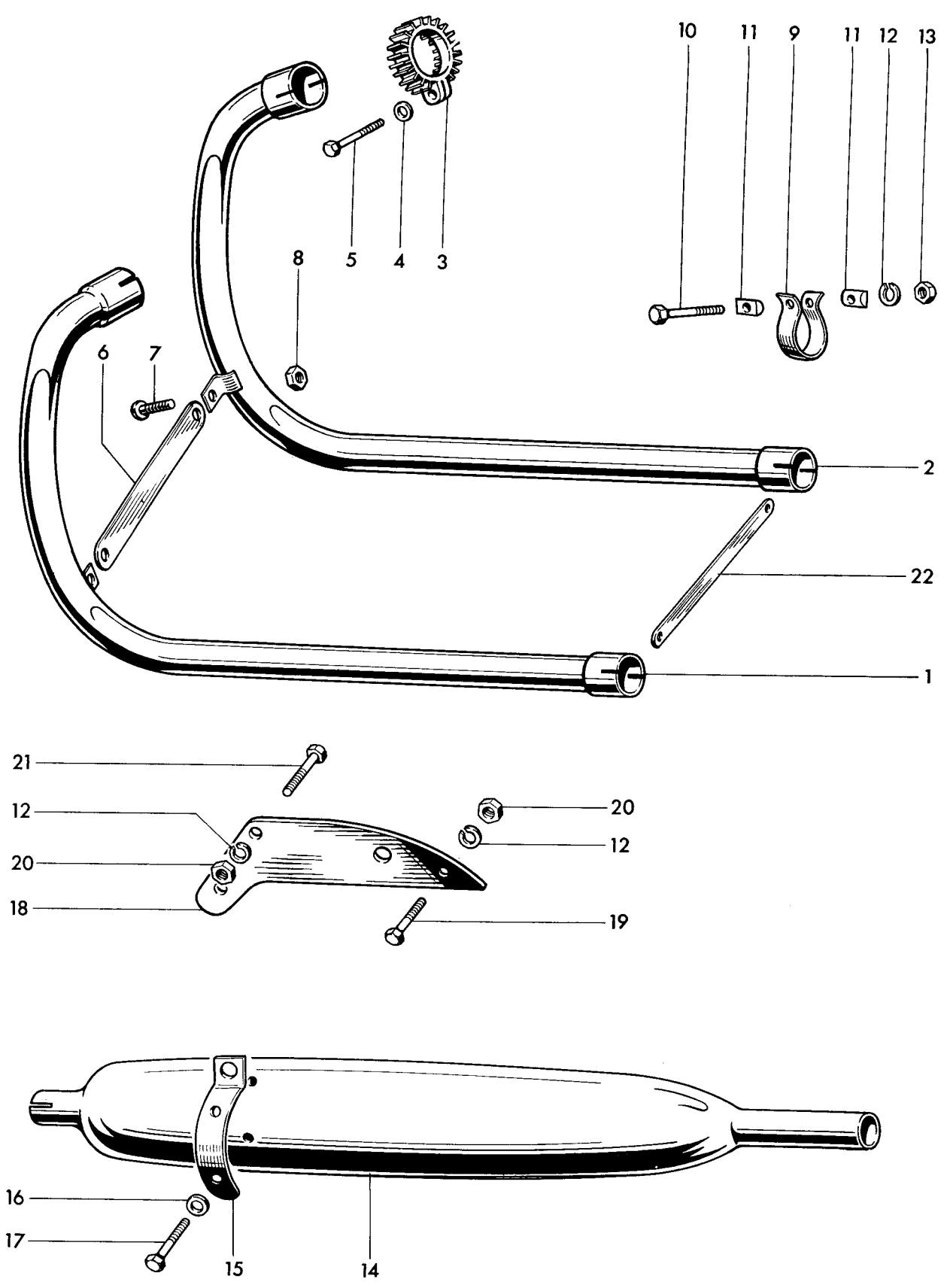

Fig. 15. EXHAUST PIPES AND SILENCERS

Ref. No.	Part No.	DESCRIPTION	QUANTITY		
----------	----------	-------------	----------	--	--

**EXHAUST PIPES AND SILENCERS**

			6T	TR6	T120
1	E5957	Left exhaust pipe ... ..	1	1	1
2	E5958	Right exhaust pipe ... ..	1	1	1
3	E4501	Finned clip ... ..	2	2	2
4	E410A	Hemispherical washer ... ..	2	2	2
5	E409	Bolt (1 $\frac{3}{8}$ in. U.H.) ... ..	2	2	2
6	E6052	Stay ... ..	1	1	1
7	F5001	Bolt ( $\frac{9}{16}$ in. U.H.) ... ..	2	2	2
8	E3290	Self locking nut ... ..	2	2	2
9	E2271	Clip ... ..	2	2	2
10	F3430	Bolt (1 $\frac{3}{4}$ in. U.H.) ... ..	2	2	2
11	E3768	"D" washer ... ..	4	4	4
12	S26-3	Spring washer ... ..	8	8	8
13	E1310	Nut ... ..	2	2	2
14	E4949	Silencer ... ..	2	2	2
15	E4951	Bracket ... ..	2	2	2
16	S25-3	Plain washer ... ..	4	4	4
17	F929	Bolt ( $\frac{1}{2}$ in. U.H.) ... ..	4	4	4
18	E4711	Pillion footrest support ... ..	2	2	2
19	F2335	Bolt ( $\frac{11}{16}$ in. U.H.) ... ..	2	2	2
20	SI-51	Nut ... ..	6	6	6
21	DS58	Bolt ( $\frac{27}{32}$ in. U.H.) ... ..	2	2	2
22	E5676	Stay ... ..	1	1	1





Ref. No.	Part No.	DESCRIPTION	QUANTITY
		<b>TELESCOPIC FRONT FORK, 6T</b>	
1	H1914	FORK ASSEMBLY ... ..	6T
2	H1577	Middle lug and stem ... ..	1
3	H439	Bottom cone ... ..	1
4	H941	Pinch bolt (2¼ in. U.H.) ... ..	2
5	S25-2	Plain washer ... ..	2
6	E2412	Nut ... ..	2
7	H1141	Fork stem sleeve nut ... ..	1
8	H1528	TOP LUG ASSEMBLY ... ..	1
9	H1527	Bonded bush ... ..	2
10	H1523	Handlebar eyebolt ... ..	2
11	F1335	Plain washer ... ..	2
12	H1340	Bolt (1½ in. U.H.) ... ..	2
13	H1708	Plain washer ... ..	2
14	H1529	Hemispherical washer ... ..	2
15	F3955	Self locking nut ... ..	2
16	F1760	Pinch bolt (1½ in. U.H.) ... ..	1
17	H379	Seated nut ... ..	1
18	H1290	Left nacelle cover ... ..	1
19	H1291	Right nacelle cover ... ..	1
20	F4047	Cork washer ... ..	2
21	H1745	Plain washer ... ..	2
22	H1916	Upper cover tube ... ..	2
23	H1891	Solo main spring (Yellow/Blue) ... ..	2
23	H1892	Sidecar main spring (Yellow/Green) ... ..	2
24	H1656	Plain washer ... ..	2
25	H1654	DUST EXCLUDER SLEEVE NUT ... ..	2
26	H1500	Oil seal ... ..	2
27	H431	Plain washer ... ..	2
28	H441	Top bearing ... ..	2
29	H1896	Damping sleeve ... ..	2
30	H1890	STANCHION c/w BEARING ... ..	2
31	H443	Lower bearing ... ..	2
32	H1058	Bearing nut ... ..	2
33	H1659	Cap nut ... ..	2
34	H519A	Oil filler plug (¾ in.) ... ..	2
35	H1842	LEFT BOTTOM MEMBER c/w CAP ... ..	2
36	H1843	RIGHT BOTTOM MEMBER c/w CAP ... ..	1
37	H1844	Spindle cap ... ..	2
38	S26-3	Spring washer ... ..	1
39	H1070	Cap bolt (1⅞ in. U.H.) ... ..	4
40	H1071	Drain plug ... ..	2
41	H430	Fibre washer ... ..	4
42	H1499	Restrictor ... ..	2
43	H1063	Flanged bolt (2⅜ in. U.H.) ... ..	2
44	H1062	Aluminium washer ... ..	2
45	H1142	Steering damper rod c/w knob ... ..	1
46	H565	Plain washer ... ..	1
47	H408	Adjuster sleeve ... ..	1
48	H1286	Locating pin ... ..	1
49	H95	Spring plate ... ..	1
50	H413	Anchor plate ... ..	1
51	H435	Friction disc ... ..	1
52	H1618	Rubber sleeve ... ..	1

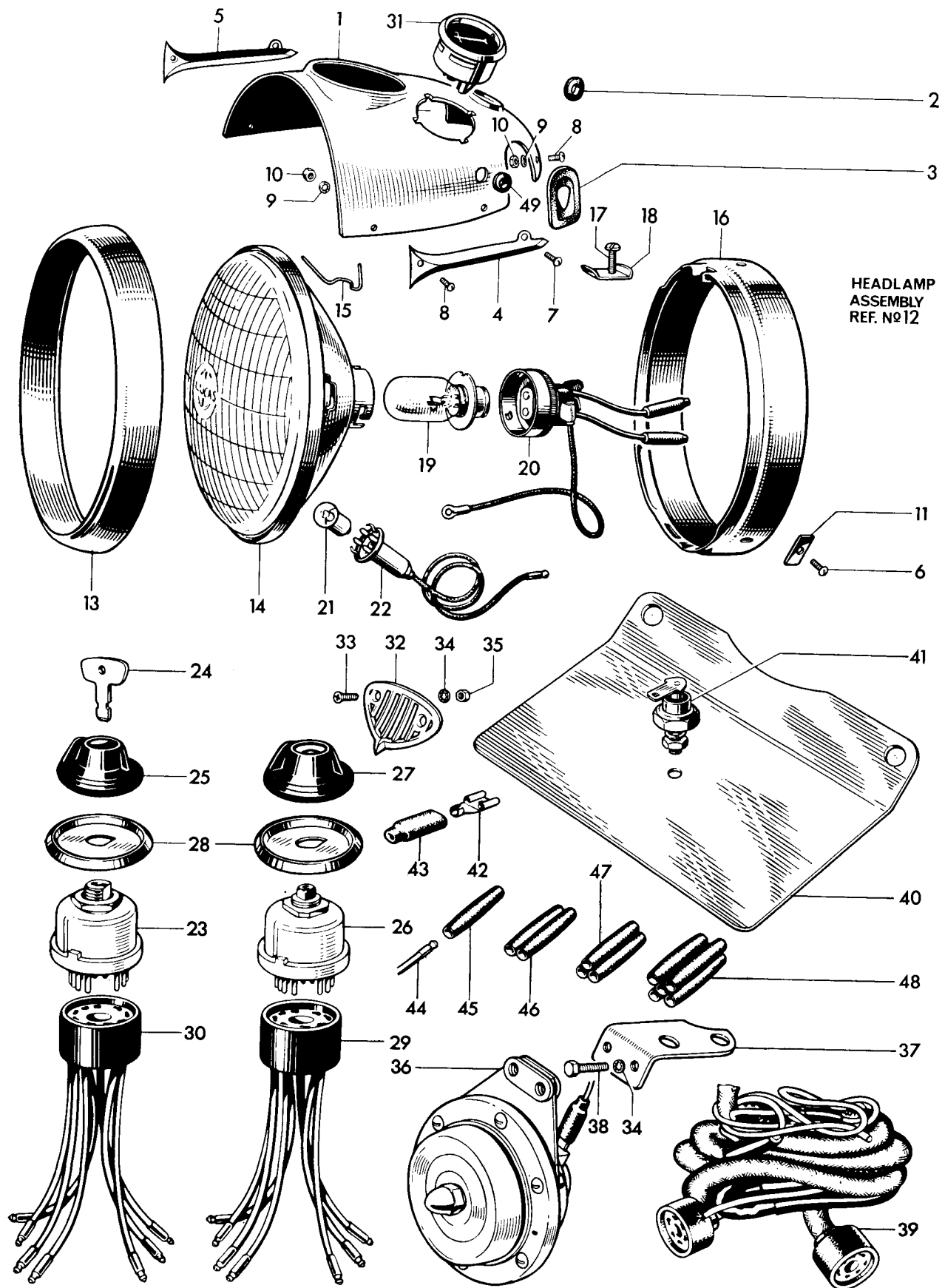

Fig. 17. NACELLE HEADLAMP AND SWITCHES

**NACELLE HEADLAMP AND SWITCHES**

			6T
1	H1781	Nacelle top ... ..	1
2	H961	Rubber grommet ... ..	1
3	H669	Rubber grommet ... ..	2
4	H877	Left motif ... ..	1
5	H878	Right motif ... ..	1
6	H689	Screw (1/4 in. U.H.) ... ..	4
7	H687	Screw (3/8 in. U.H.) ... ..	2
8	H688	Screw (5/16 in. U.H.) ... ..	2
9	E2880	Serrated washer ... ..	4
10	H691	Nut ... ..	4
11	H690	Nut ... ..	2
12	59176	HEADLAMP ... ..	1
13	553248	Rim ... ..	1
14	516812	Light unit ... ..	1
15	504665	Fixing wire... ..	6
16	553267	Fixing ring ... ..	1
17	144921	Screw ... ..	1
18	534296	Plate ... ..	1
19	414	Bulb (50/40 W. L.H. dipping. Pre-focus)	1
20	554602	Adaptor ... ..	1
21	222	Bulb (4W.M.C.C.) ... ..	1
22	554710	Pilot bulbholder ... ..	1
23	34427	IGNITION SWITCH c/w KEY, type 88SA	1
24	54336176	Ignition key ... ..	1
25	54336178	Ignition switch cover ... ..	1
26	34289	Lighting switch, type 88SA ... ..	1
27	54330934	Knob c/w screw ... ..	2
28	54330576	Switch bezel plate ... ..	A
29	54930007	Replacement harness socket (lighting)	A
30	54930008	Replacement harness socket (ignition)	1
31	36296	Ammeter, type 2AR ... ..	1
32	H992	Horn grille ... ..	2
33	H993	Screw (0.540 in. U.H.) ... ..	4
34	GS299	Serrated washer ... ..	2
35	F3799	Nut ... ..	1
36	H1420	Horn bracket ... ..	1
37	70164	Horn, type 8H ... ..	2
38	F4771	Bolt (1/2 in. U.H.) ... ..	1
39	54094523	Wiring harness ... ..	1
40	F5762	Mounting plate ... ..	1
41	49345	Zener diode ... ..	2
42	54942078	Lucar connector ... ..	2
43	54190042	Insulating cover... ..	as required
44	900269	Snap connector terminal ... ..	as required
45	900288	Single snap connector ... ..	as required
46	850641	Double snap connector ... ..	as required
47	850844	Triple snap connector ... ..	as required
48	850832	Quintuple snap connector ... ..	2
49	H1938	Blind grommet ... ..	

ASSEMBLY REF. No.1

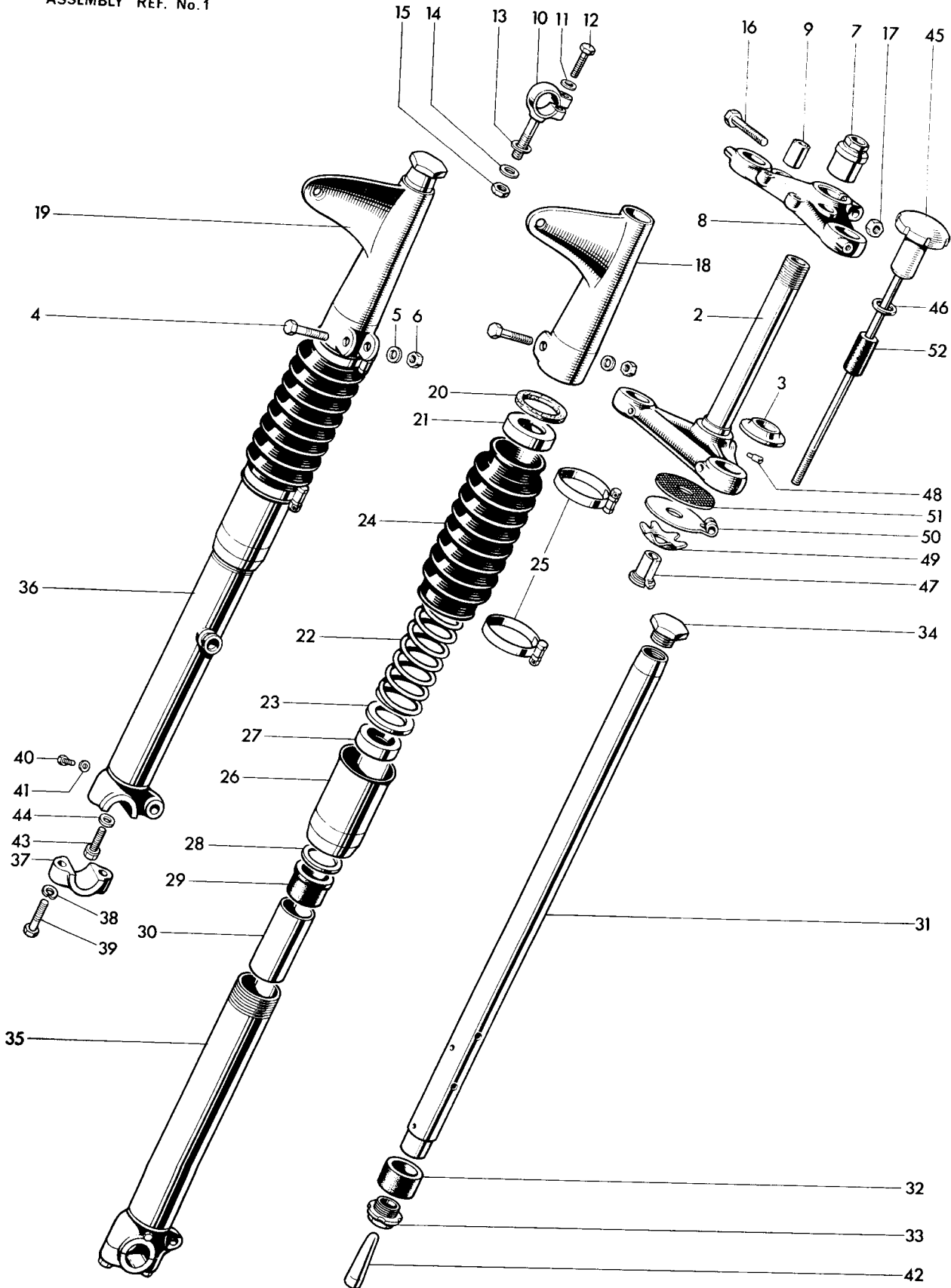

Fig. 18. TELESCOPIC FRONT FORK, TR6 AND T120

**TELESCOPIC FRONT FORK, TR6 AND T120**

			TR6	T120
1	H1924	FORK ASSEMBLY ... ..	1	1
2	H1577	Middle lug and stem ... ..	1	1
3	H439	Bottom cone ... ..	1	1
4	H941	Pinch bolt (2¼ in. U.H.) ... ..	2	2
5	S25-2	Plain washer ... ..	2	2
6	E2412	Nut ... ..	2	2
7	H405	Fork stem sleeve nut ... ..	1	1
8	H1528A	TOP LUG ASSEMBLY ... ..	2	2
9	H1527	Bonded bush ... ..	2	2
10	H1523	Handlebar eyebolt ... ..	2	2
11	F1335	Plain washer ... ..	2	2
12	H1340	Bolt (1⅛ in. U.H.) ... ..	2	2
13	H1708	Plain washer ... ..	2	2
14	H1529	Hemispherical washer ... ..	2	2
15	F3955	Self-locking nut ... ..	2	2
16	F1760	Pinch bolt (1⅞ in. U.H.) ... ..	1	1
17	H379	Seated nut ... ..	1	1
18	H1888	Left top cover ... ..	1	1
19	H1887	Right top cover ... ..	1	1
20	F4047	Cork washer ... ..	2	2
21	H1657	Spring abutment ... ..	2	2
22	H1891	Solo main spring (Yellow/Blue) ... ..	2	2
22	H1892	Sidecar main spring (Yellow/Green) ... ..	2	2
23	H1656	Plain washer ... ..	2	2
24	H1645	Telescopic gaiter ... ..	2	2
25	D340	Gaiter clip ... ..	4	4
26	H1654	DUST EXCLUDER SLEEVE NUT ... ..	2	2
27	H1500	Oil seal ... ..	2	2
28	H431	Plain washer ... ..	2	2
29	H441	Top bearing ... ..	2	2
30	H1896	Damping sleeve ... ..	2	2
31	H1889	STANCHION c/w BEARING ... ..	2	2
32	H443	Lower bearing ... ..	2	2
33	H1058	Bearing nut ... ..	2	2
34	H1658	Cap nut ... ..	2	2
35	H1842	LEFT BOTTOM MEMBER c/w CAP ... ..	1	1
36	H1843	RIGHT BOTTOM MEMBER c/w CAP ... ..	1	1
37	H1844	Spindle cap ... ..	2	2
38	S26-3	Spring washer ... ..	4	4
39	H1070	Cap bolt (1⅞ in. U.H.) ... ..	4	4
40	H1071	Drain plug ... ..	2	2
41	H430	Fibre washer ... ..	2	2
42	H1499	Restrictor ... ..	2	2
43	H1063	Flanged bolt (2⅜ in. U.H.) ... ..	2	2
44	H1062	Aluminium washer ... ..	2	2
45	H1142	Steering damper rod c/w knob ... ..	1	1
46	H565	Plain washer ... ..	1	1
47	H408	Adjuster sleeve ... ..	1	1
48	H1286	Locating pin ... ..	1	1
49	H95	Spring plate ... ..	1	1
50	H413	Anchor plate ... ..	1	1
51	H435	Friction disc ... ..	1	1
52	H1618	Rubber sleeve ... ..	1	1

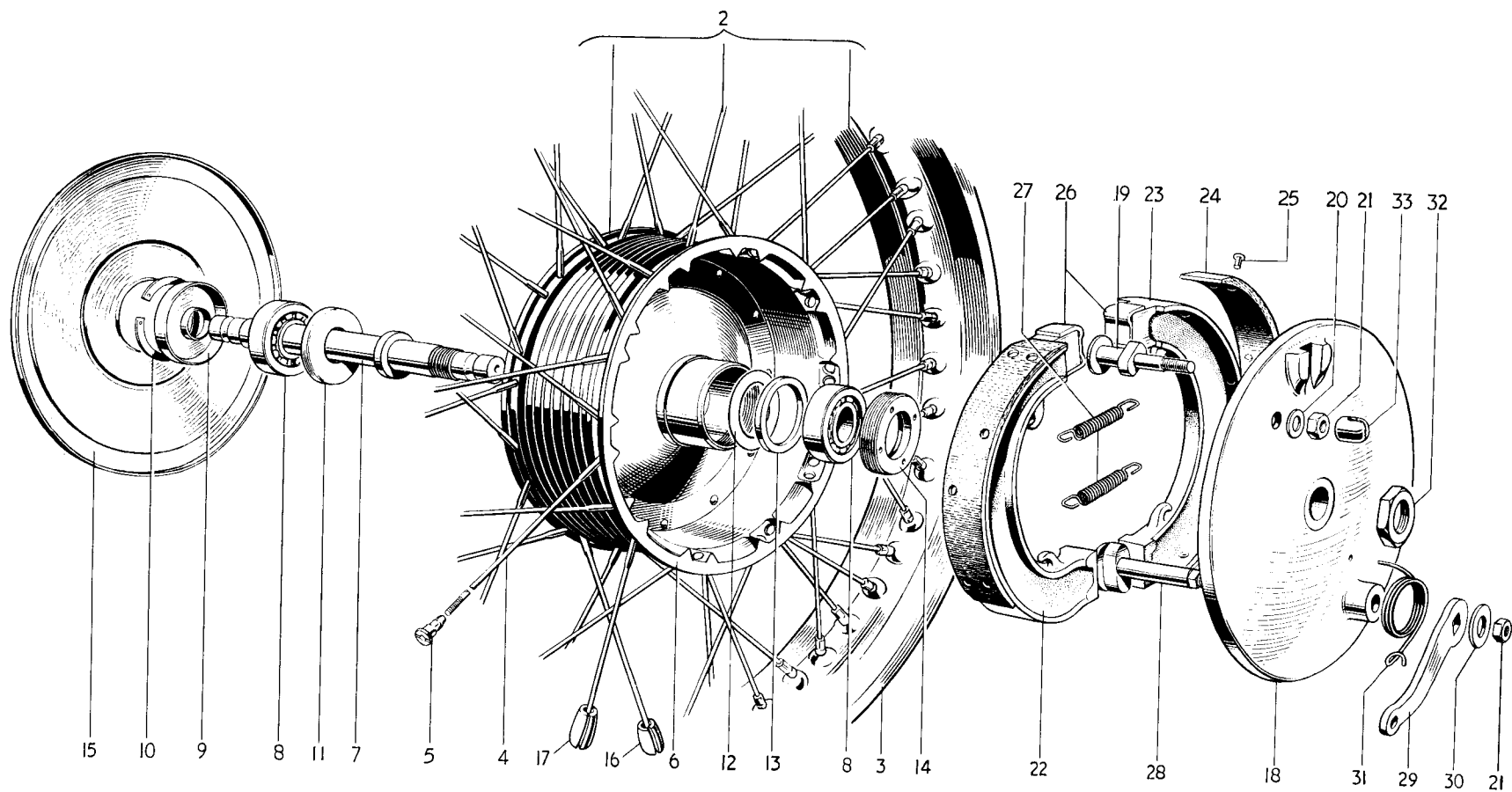

Fig. 19. FRONT WHEEL

Ref. No.	Part No.	DESCRIPTION	QUANTITY		
<b>FRONT WHEEL</b>					
			6T	TR6	T120
1	W1662	FRONT WHEEL COMPLETE ... ..	1	-	1
1	W1667	FRONT WHEEL COMPLETE ... ..	-	1	-
2	W1371	RIM, SPOKES AND HUB ASSEMBLY ... ..	1	-	1
2	W1324	RIM, SPOKES AND HUB ASSEMBLY ... ..	-	1	-
3	W1374	Front wheel rim (WM2-18) ... ..	1	-	1
3	W1230	Front wheel rim (WM2-19) ... ..	-	1	-
4	W1275	Spoke (8/10G x 5 $\frac{1}{8}$ in. straight) c/w nipple ... ..	40	-	40
4	W1328	Spoke (8/10G x 5 $\frac{3}{8}$ in. straight) c/w nipple ... ..	-	40	-
5	S79-2	Spoke nipple ... ..	40	40	40
6	W1325	Hub and brake drum ... ..	1	1	1
7	W1641	Wheel spindle ... ..	1	1	1
8	W653	Bearing ... ..	2	2	2
9	W1237	Dust cover ... ..	1	1	1
10	T280	Circlip ... ..	1	1	1
11	W1481	Grease retainer ... ..	1	1	1
12	W1474	Grease retainer (brake side) ... ..	1	1	1
13	W1238	Backing ring ... ..	1	1	1
14	W582	Retaining ring ... ..	1	1	1
15	W1332	Cover plate ... ..	1	1	1
16	W1197	Balance weight, $\frac{1}{2}$ oz. ... ..		as required	
17	W1198	Balance weight, 1 oz. ... ..		as required	
18	W1330	Brake anchor plate ... ..	1	1	1
19	W1639	Fulcrum pin ... ..	1	1	1
20	S25-2	Plain washer ... ..	1	1	1
21	S1-52	Nut ... ..	2	2	2
22	W1410	LEADING BRAKE SHOE c/w LINING ... ..	1	1	1
23	W1411	TRAILING BRAKE SHOE c/w LINING ... ..	1	1	1
24	W1414	Brake lining ... ..	2	2	2
25	W129	Brass rivet ... ..	16	16	16
26	W1415	Pivot pad ... ..	2	2	2
27	W135	Shoe return spring ... ..	2	2	2
28	W1243	Brake cam ... ..	1	1	1
29	W1331X	Brake cam lever ... ..	1	1	1
30	S25-6	Plain washer ... ..	1	1	1
31	W592	Lever return spring ... ..	1	1	1
32	W1246	Anchor plate nut ... ..	1	1	1
33	W1640	Abutment ... ..	1	1	1



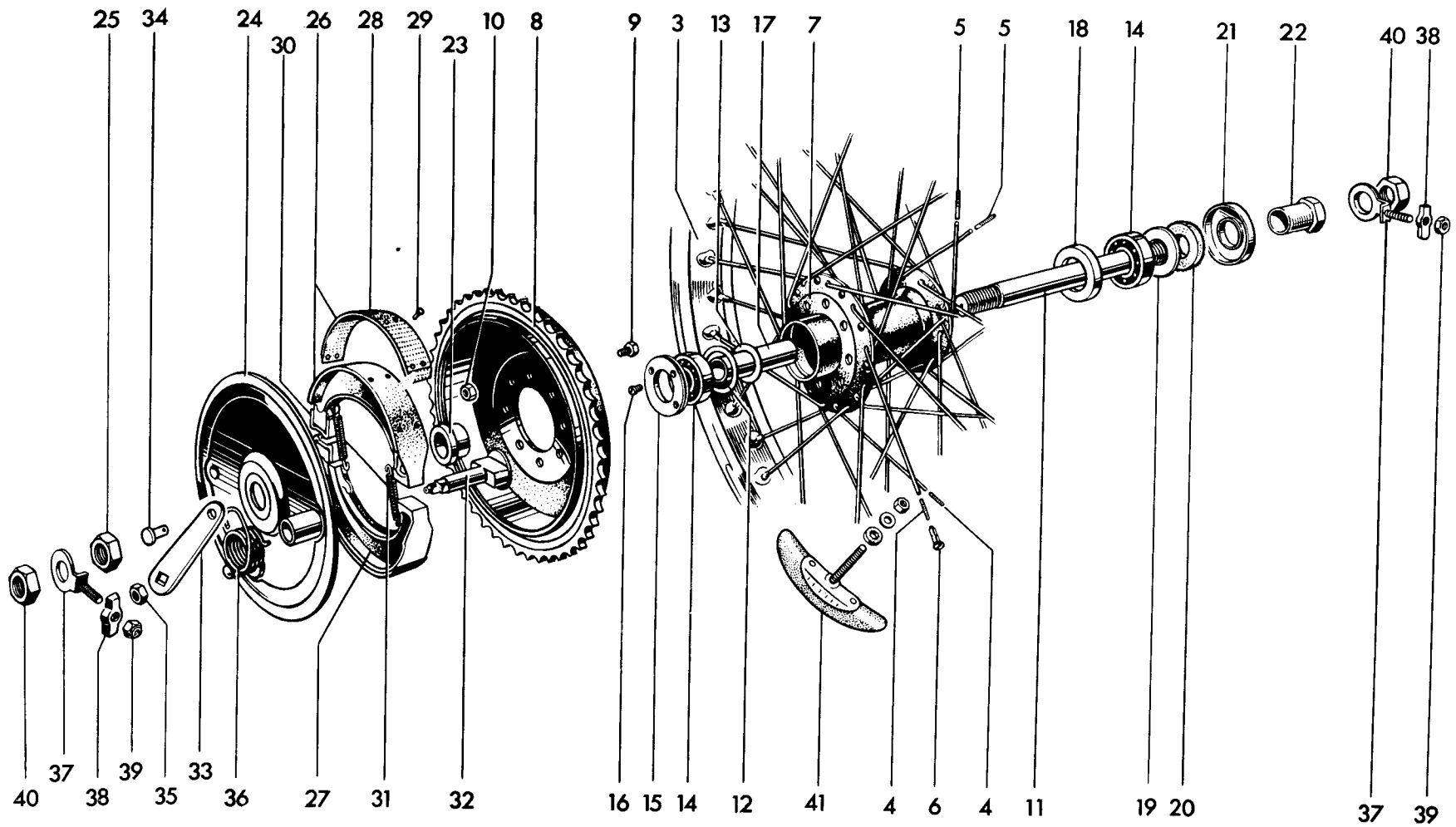

Fig. 20. REAR WHEEL

Ref. No.	Part No.	DESCRIPTION	QUANTITY		
<b>REAR WHEEL</b>					
			6T	TR6	T120
1	W1659	REAR WHEEL COMPLETE ... ..	1	-	1
1	W1668	REAR WHEEL COMPLETE ... ..	-	1	-
2	W1470	RIM, SPOKES AND HUB ASSEMBLY ... ..	1	-	1
2	W1486	RIM, SPOKES AND HUB ASSEMBLY ... ..	-	1	-
3	W1471	Rear wheel rim (WM2-18) ... ..	1	-	1
3	W1007	Rear wheel rim (WM3-18) ... ..	-	1	-
4	W1107	Spoke (8/10G x 7 <sup>3</sup> / <sub>16</sub> in. 90°) c/w nipple ... ..	20	20	20
5	W1108	Spoke (8/10G x 7 <sup>3</sup> / <sub>8</sub> in. 90°) c/w nipple ... ..	20	20	20
6	S79-2	Spoke nipple ... ..	40	40	40
7	W1472	Hub ... ..	1	1	1
8	W951	Sprocket and brake drum (46T) ... ..	1	1	1
9	W62	Sprocket to hub bolt (1 <sup>1</sup> / <sub>8</sub> in. U.H.) ... ..	8	8	8
10	W1495	Self-locking nut ... ..	8	8	8
11	W1281	Wheel spindle ... ..	1	1	1
12	W1022	Backing ring ... ..	1	1	1
13	W1474	Grease retainer ... ..	1	1	1
14	W653	Bearing ... ..	2	2	2
15	W1021	RETAINER RING ... ..	1	1	1
16	W1079	Locking screw (5 <sup>5</sup> / <sub>16</sub> in. U.H.) ... ..	1	1	1
17	W1278	Distance tube ... ..	1	1	1
18	W1654	Grease retainer ... ..	1	1	1
19	W1635	Locating disc ... ..	1	1	1
20	W1638	Felt washer ... ..	1	1	1
21	W1637	Dust cover ... ..	1	1	1
22	W1478	Nut ... ..	1	1	1
23	W1024	Distance piece ... ..	1	1	1
24	W1112	Brake anchor plate ... ..	1	1	1
25	F1747	Nut ... ..	1	1	1
26	W1406	LEADING BRAKE SHOE c/w LINING ... ..	1	1	1
27	W1407	TRAILING BRAKE SHOE c/w LINING ... ..	1	1	1
28	NW243	Brake lining ... ..	2	2	2
29	W129	Brass rivet ... ..	16	16	16
30	W1415	Pivot pad ... ..	2	2	2
31	W135	Shoe return spring ... ..	2	2	2
32	W1083	Brake cam ... ..	1	1	1
33	W1466	Brake cam lever ... ..	1	1	1
34	W1467	Pivot pin ... ..	1	1	1
35	S1-52	Nut ... ..	1	1	1
36	W1090	Lever return spring ... ..	1	1	1
37	W1134	Chain adjuster ... ..	2	2	2
38	W1015	Adjuster end plate ... ..	2	2	2
39	W1058	Self locking nut ... ..	2	2	2
40	F1747	Spindle nut ... ..	2	2	2
41	D106	Tyre security bolt ... ..	2	-	2
41	WM3	Tyre security bolt ... ..	-	2	-

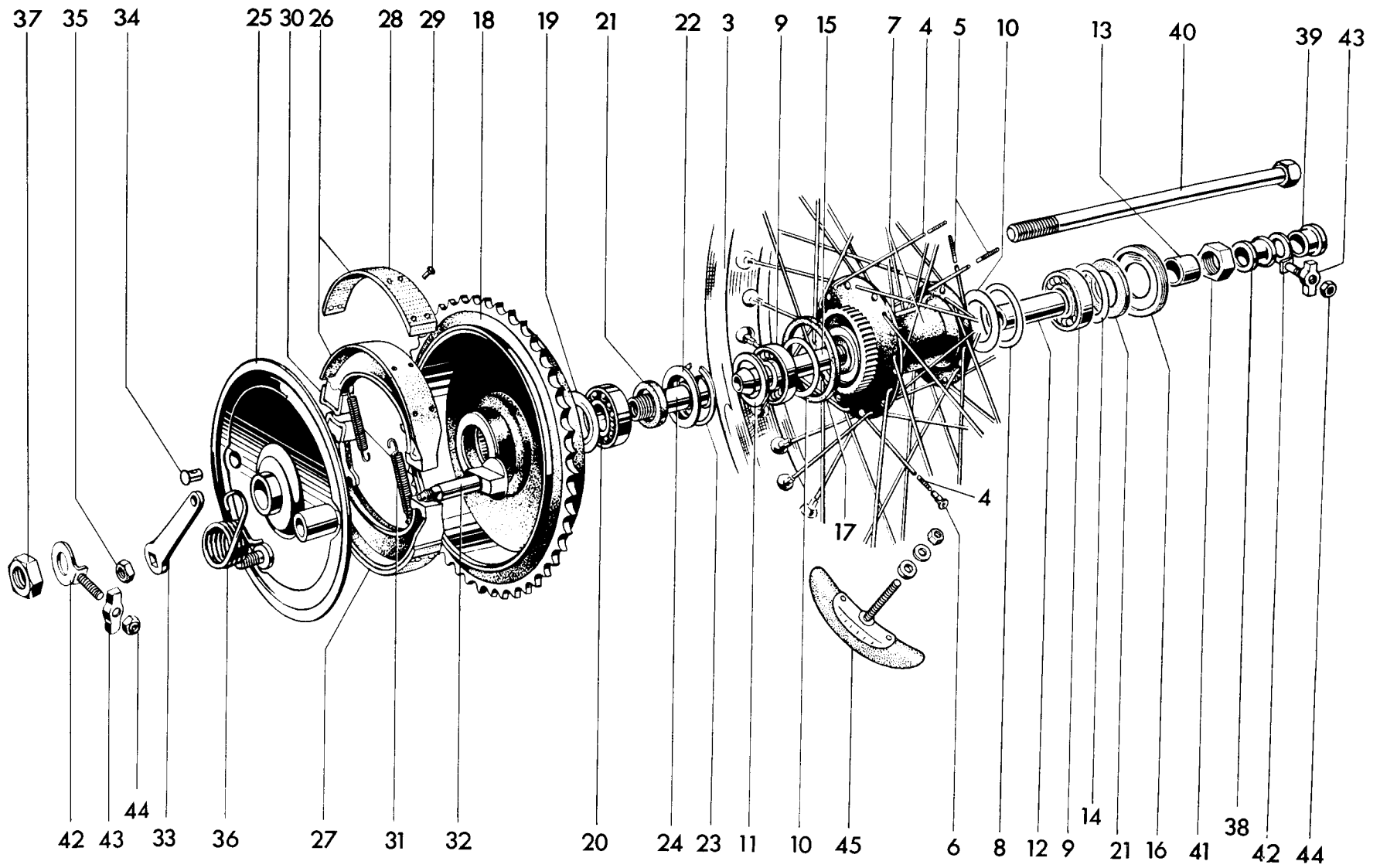

Fig. 21. QUICKLY DETACHABLE REAR WHEEL

Ref. No.	Part No.	DESCRIPTION	QUANTITY		
<b>QUICKLY DETACHABLE REAR WHEEL</b>			6T	TR6	T120
1	W1600	Q.D. REAR WHEEL COMPLETE ... ..	1	1	1
2	W1603	RIM, SPOKES AND HUB ASSEMBLY ... ..	1	1	1
3	W1007	Rear wheel rim (WM3-18)... ..	1	1	1
4	W1107	Spoke (8/10G x 7 <sup>9</sup> / <sub>16</sub> in. 90°) c/w nipple ... ..	20	20	20
5	W1108	Spoke (8/10G x 7 <sup>7</sup> / <sub>8</sub> in. 90°) c/w nipple ... ..	20	20	20
6	S79-2	Spoke nipple ... ..	40	40	40
7	W1593	Hub ... ..	1	1	1
8	W1509	Backing ring ... ..	1	1	1
9	S35-7	Bearing ... ..	2	2	2
10	W1595	Grease retainer ... ..	2	2	2
11	W1596	Dust cap ... ..	1	1	1
12	W1598	Distance piece ... ..	1	1	1
13	W1597	Distance piece ... ..	1	1	1
14	W1635	Locating disc ... ..	1	1	1
15	W1039	Bearing sleeve ... ..	1	1	1
16	W1636	Bearing retainer ring ... ..	1	1	1
17	W1091	Rubber sealing ring ... ..	1	1	1
18	W1040	Sprocket and brake drum (46T) ... ..	1	1	1
19	W1143	Grease retainer ... ..	1	1	1
20	W1041	Bearing ... ..	2	2	2
21	W1042	Felt washer ... ..	1	1	1
22	W1043	Bearing and felt retainer ... ..	1	1	1
23	W1044	Circlip ... ..	1	1	1
24	W1045	Bearing sleeve ... ..	1	1	1
25	W1121	Brake anchor plate ... ..	1	1	1
26	W1406	LEADING BRAKE SHOE c/w LINING ... ..	1	1	1
27	W1407	TRAILING BRAKE SHOE c/w LINING ... ..	2	2	2
28	NW243	Brake lining ... ..	16	16	16
29	W129	Brass rivet ... ..	2	2	2
30	W1415	Pivot pad ... ..	2	2	2
31	W135	Shoe return spring ... ..	1	1	1
32	W1083	Brake cam ... ..	1	1	1
33	W1466	Brake cam lever ... ..	1	1	1
34	W1467	Pivot pin ... ..	1	1	1
35	S1-52	Nut ... ..	1	1	1
36	W1090	Lever return spring ... ..	1	1	1
37	W1052	Nut ... ..	1	1	1
38	W1053	Inner distance piece ... ..	1	1	1
39	W1170	Outer distance piece ... ..	1	1	1
40	W1055	Spindle ... ..	1	1	1
41	F1747	Nut ... ..	2	2	2
42	W1135	Chain adjuster ... ..	2	2	2
43	W1015	Adjuster end plate ... ..	2	2	2
44	W1058	Self locking nut ... ..	2	2	2
45	WM3	Tyre security bolt ... ..	2	2	2



Ref. No.	Part No.	DESCRIPTION	QUANTITY		
<b>PETROL TANKS</b>					
			6T	TR6	T120
1	F5260	Petrol tank (4 gallons)	1	1	1
2	F4148	Styling strip (left, front)	1	1	1
3	F4766	Styling unit (left)	1	1	1
4	F4129	Styling unit screw (0.435 in. U.H.)	4	4	4
5	F4151	Styling strip (right front)	1	1	1
6	F4767	Styling unit (right)	1	1	1
7	F5401	Left knee grip	1	1	1
8	F5402	Right knee grip	1	1	1
9	F5398	Centre styling strip	1	1	1
10	F4019	Serrated washer	1	1	1
11	H919	Nut	1	1	1
12	F5416	Petrol tank (3 gallons)	-	A	A
13	F4235	Styling strip (left, front)	-	A	A
14	F4127	Styling unit (left)	-	A	A
15	F4236	Styling strip (left, rear)	-	A	A
16	F3915	Knee grip plate (left)	-	A	A
17	S25-13	Plain washer	-	A	A
18	T361	Knee grip plate bolt ( $\frac{1}{4}$ in. U.H.)	-	A	A
19	F1606	Knee grip (left)	-	A	A
20	F4237	Styling strip (right, front)	-	A	A
21	F4128	Styling unit (right)	-	A	A
22	F4238	Styling strip (right, rear)	-	A	A
23	F3916	Knee grip plate (right)	-	A	A
24	F1605	Knee grip (right)	-	A	A
25	F5564	Centre styling strip	-	A	A
26	F3220	FILLER CAP	1	1	1
27	F4048	Joint washer	1	1	1
28	F4971	Petrol tap (left)...	1	1	1
29	F4972	Petrol tap with reserve tube	1	1	1
30	F1511	Fibre washer	2	2	2
31	F5228	Rubber washer	2	2	2
32	F5229	Spigot rubber	2	2	2
33	F3814	Cup	3	3	3
34	F1808	Bolt ( $1\frac{3}{16}$ in. U.H.)	2	2	2
35	F5336	Double spigot rubber	1	1	1
36	F967	Rubber washer	1	1	1
37	F5337	Bolt ( $1\frac{1}{32}$ in. U.H.)	1	1	1
38	F3917	Parcel grid	1	1	1
39	F2936	Screw	1	1	1
40	F4384	Rubber blanking plug	A	A	A

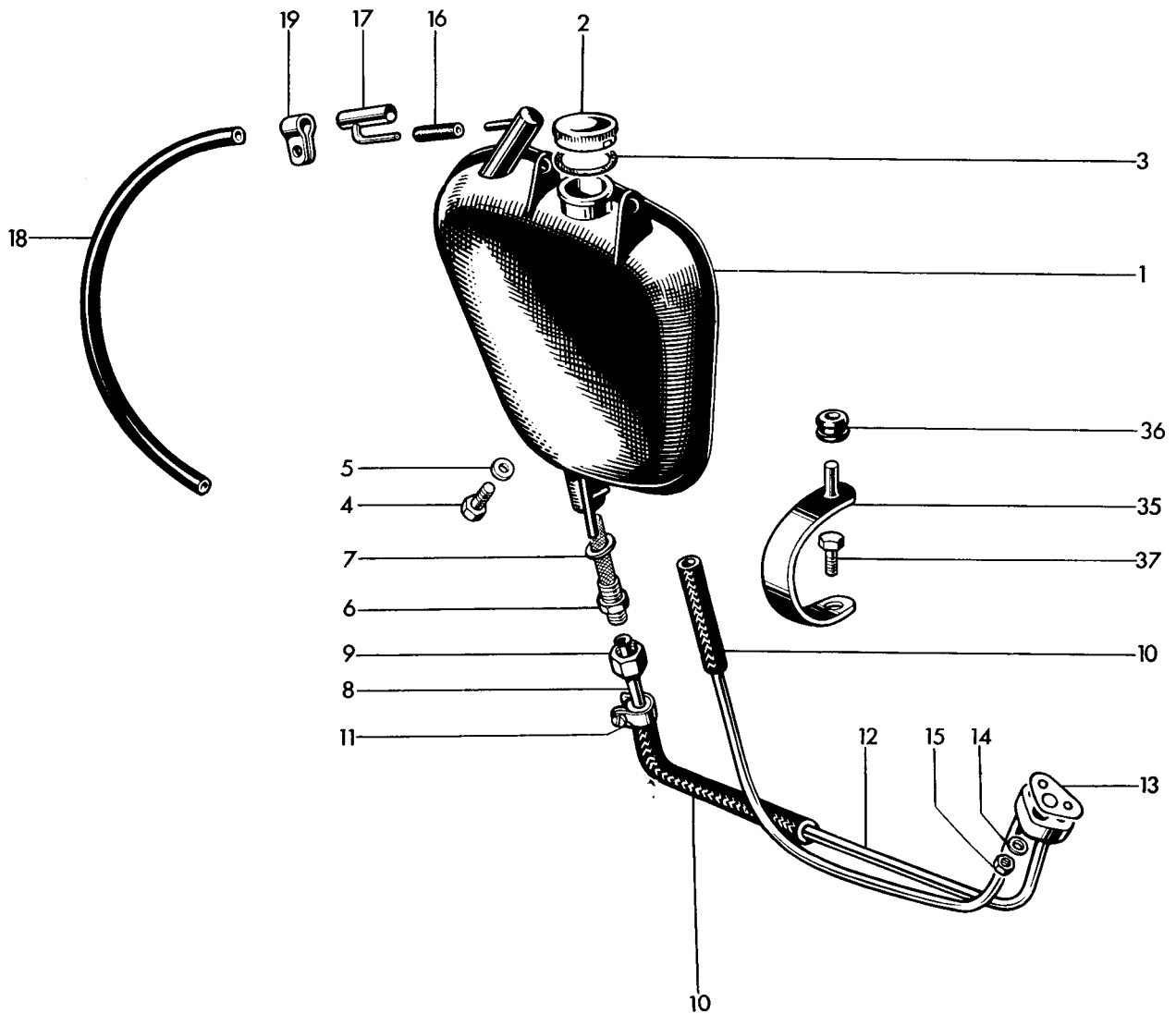
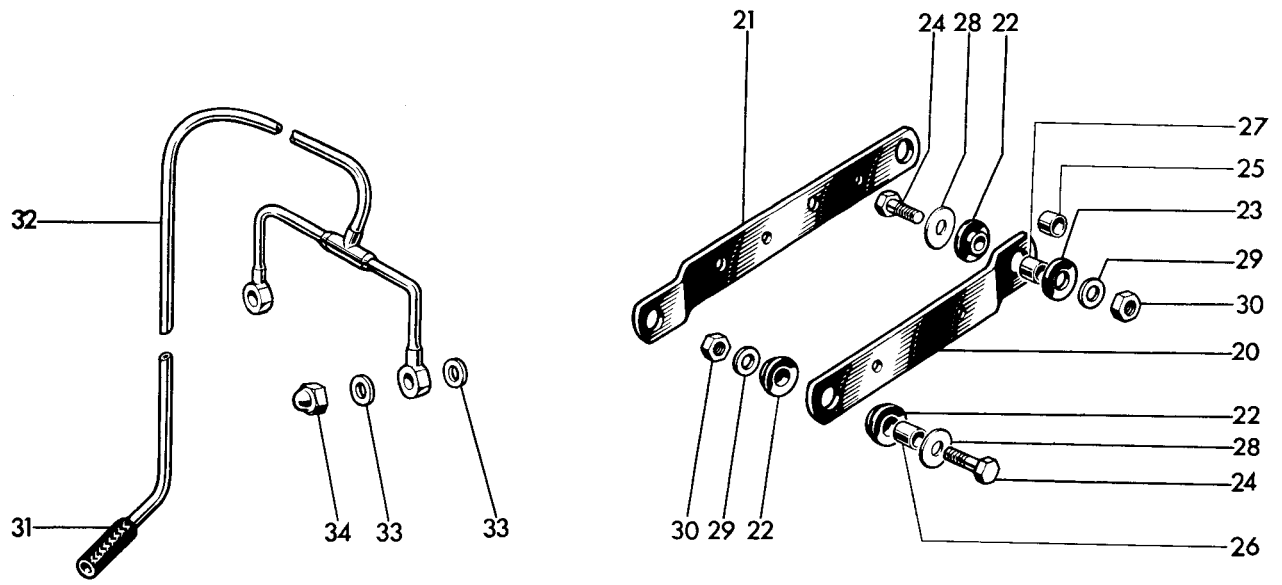

Fig. 23. OIL TANK

Ref. No.	Part No.	DESCRIPTION	QUANTITY		
<b>OIL TANK</b>					
			6T	TR6	T120
1	F6038	Oil tank ...	1	1	1
2	F3216	FILLER CAP ...	1	1	1
3	F4047	Joint washer ...	1	1	1
4	F5343	Drain plug ...	1	1	1
5	PT104B	Fibre washer ...	1	1	1
6	F3179	Oil tank filter ...	1	1	1
7	F1713	Fibre washer ...	1	1	1
8	F3655	Upper feed pipe ...	1	1	1
9	F3182	Union nut ...	1	1	1
10	E4594	Flexible connector ...	2	2	2
11	E5473	Clip ...	4	4	4
12	E4590	Oil pipes and junction block ...	1	1	1
13	E3763	Joint washer ...	1	1	1
14	E3446	Plain washer ...	1	1	1
15	E1310	Nut ...	1	1	1
16	E5374	Vent pipe ...	1	1	1
17	E5370	"T" piece ...	1	1	1
18	E5376	Extension pipe ...	1	1	1
19	F3098	Clip ...	2	2	2
20	F5949	Front strap ...	1	-	-
21	F5358	Rear Strap ...	1	-	-
20	F5328	Front strap ...	-	1	1
21	F5329	Rear strap ...	-	1	1
22	F5247	Spigot rubber ...	6	6	6
23	F5248	Rubber washer ...	2	2	2
24	W932	Bolt (1 in. U.H.) ...	4	4	4
25	F6307	Distance tube ( $\frac{13}{32}$ in. O.A.) ...	2	-	-
26	F6308	Distance tube ( $\frac{17}{32}$ in. O.A.) ...	2	2	2
27	F6309	Distance tube ( $\frac{15}{32}$ in. O.A.) ...	-	2	2
28	F6310	Plain washer (large) ...	4	4	4
29	S25-3	Plain washer (small) ...	4	4	4
30	F879	Nut ...	4	4	4
31	E3383	Rubber connector ...	1	1	1
32	E4159	Rocker oil feed pipe ...	1	1	1
33	E1335	Copper washer ...	4	4	4
34	E1435	Domed nut ...	2	2	2
35	F6147	Bracket ...	1	1	1
36	F6039	Grommet ...	1	1	1
37	F929	Bolt ( $\frac{1}{2}$ in. U.H.) ...	1	1	1



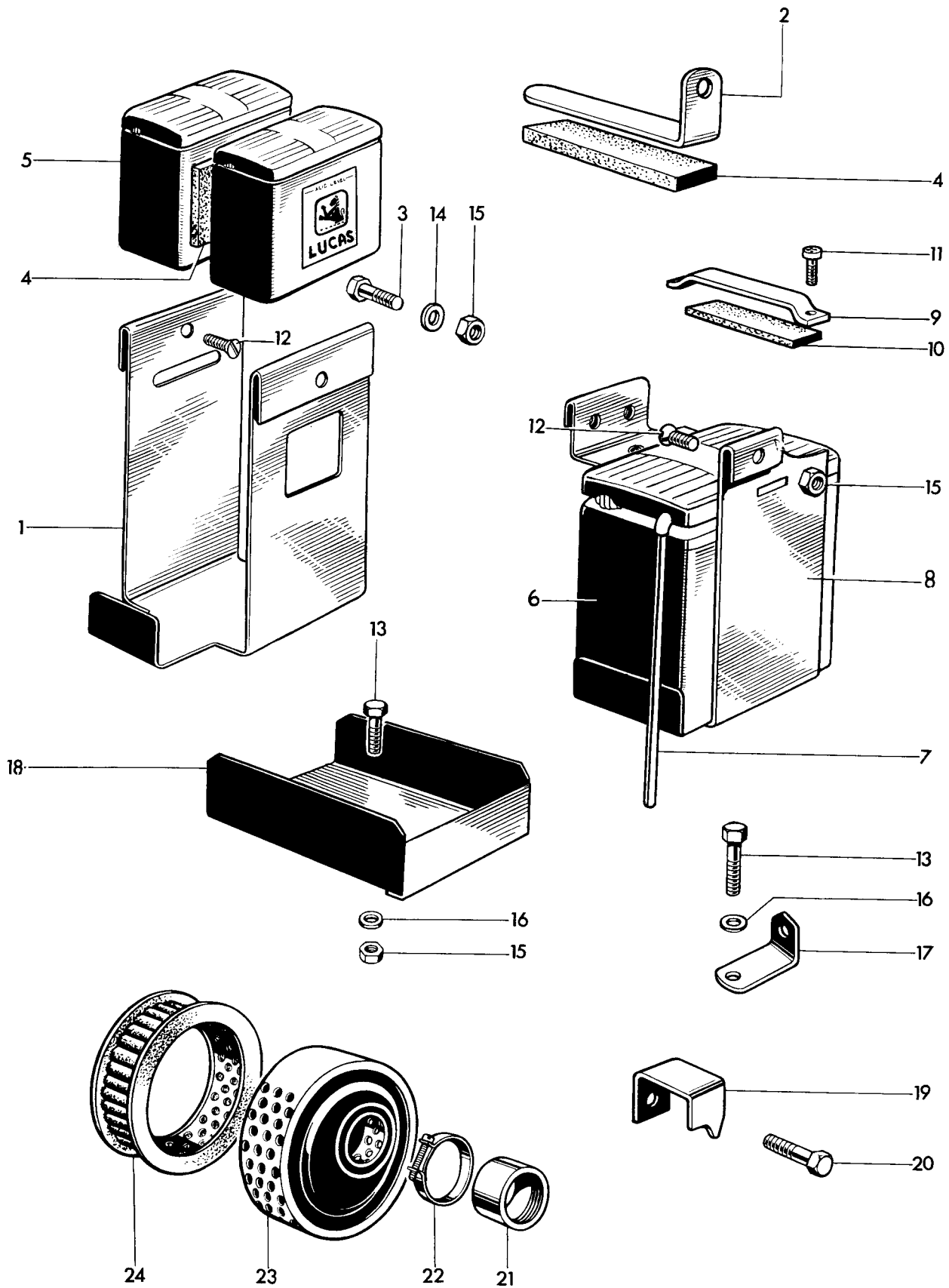

Fig. 24. BATTERY CARRIER AND AIR FILTER

**BATTERY CARRIER AND AIR FILTER**

			6T	TR6	T120
1	F5948	Battery carrier	1	-	-
2	F6129	Retainer strap	1	-	-
3	F1369	Bolt ( $\frac{5}{8}$ in. U.H.)	1	-	-
4	F3470	Rubber pad	3	-	-
5	MKZ9E	Battery	2	-	-
6	MLZ9E	Battery c/w lid	-	1	1
7	F4814	Plastic vent pipe	2	1	1
8	F5333	Battery carrier	-	1	1
9	F4661	Top strap	-	1	1
10	F4662	Packing rubber	-	1	1
11	E3200	Screw ( $\frac{1}{16}$ in. U.H.)	-	1	1
12	E3728	Screw ( $\frac{1}{32}$ in. U.H.)	2	1	1
13	DS57	Bolt ( $\frac{7}{16}$ in. U.H.)	3	3	3
14	S25-1	Plain washer	2	1	1
15	F879	Nut	6	5	5
16	S25-13	Plain washer	3	2	2
17	F4283	Rectifier bracket	1	1	1
18	F5665	Tool tray	1	1	1
19	F5414	Inflator bracket	1	1	1
20	F1369	Bolt ( $\frac{5}{8}$ in. U.H.)	1	1	1
21	F4576	Adaptor sleeve	1	-	-
22	F5625	Clip	1	-	-
23	F6430	AIR FILTER	1	-	-
24	F4811	Filter element (felt)	1	-	-
21	F5958	Adaptor sleeve	-	1	-
22	F6074	Clip	-	1	-
23	F6431	AIR FILTER	-	1	-
24	F5764	Filter element (coarse felt)	-	1	-

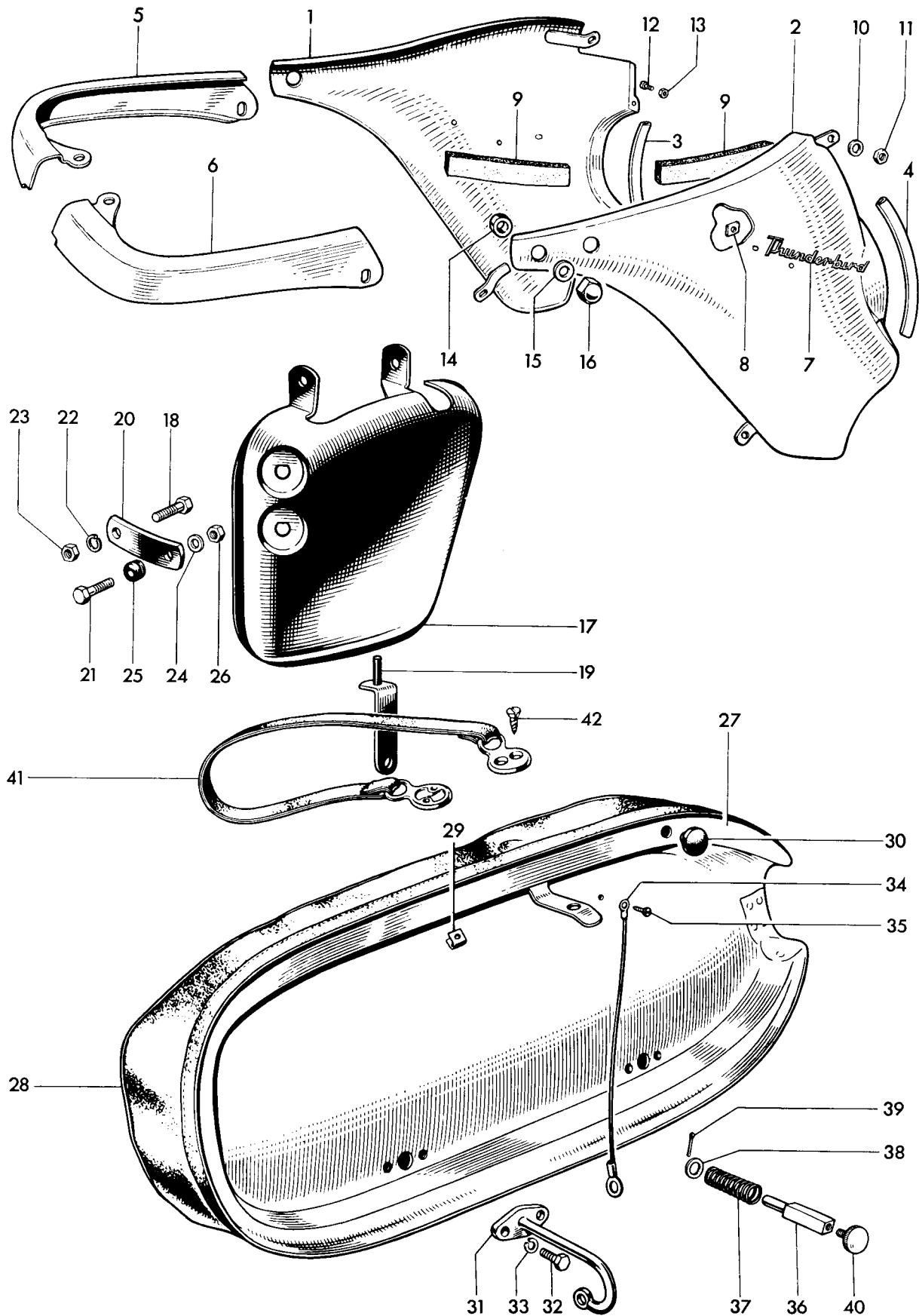

Fig. 25. PANELS AND TWINSEAT

Ref. No.	Part No.	DESCRIPTION	QUANTITY		
----------	----------	-------------	----------	--	--

**PANELS AND TWINSEAT**

			6T	TR6	T120
1	F5319	Left panel ... ..	1	-	-
2	F5320	Right panel ... ..	1	-	-
3	F6104	Left beading ... ..	1	-	-
4	F6105	Right beading ... ..	1	-	-
5	F5323	Left valance ... ..	1	-	-
6	F5324	Right valance ... ..	1	-	-
7	F6195	Motif "Thunderbird" ... ..	2	-	-
8	F4317	Spire nut ... ..	4	-	-
9	F5538	Rubber pad ... ..	2	-	-
10	S25-2	Plain washer ... ..	2	-	-
11	S1-52	Nut ... ..	2	-	-
12	F4715	Screw ( $\frac{13}{32}$ in. U.H.) ... ..	2	-	-
13	F4717	Self locking nut ... ..	2	-	-
14	F2694	Distance piece ... ..	3	-	-
15	GS308	Plain washer ... ..	4	-	-
16	E4329	Domed nut ... ..	4	-	-
17	F5394	Switch panel ... ..	-	1	1
18	F1369	Bolt ( $\frac{5}{8}$ in. U.H.) ... ..	-	1	1
19	F5939	Fixing bracket ... ..	-	1	1
20	F5923	Link ... ..	-	1	1
21	F1756	Bolt ( $\frac{3}{4}$ in. U.H.) ... ..	-	1	1
22	S26-2	Spring washer ... ..	-	2	2
23	F879	Nut ... ..	-	2	2
24	S25-43	Washer ... ..	-	1	1
25	F5466	Grommet ... ..	-	2	2
26	E3290	Self locking nut ... ..	-	1	1
27	F5366	TWINSEAT ... ..	1	1	1
28	F5418	Twinseat cover c/w clips ... ..	1	1	1
29	F4475	Clip ... ..		as required	
30	F4898	Rubber buffer ... ..	2	2	2
31	F4222	Hinge ... ..	2	2	2
32	DS57	Bolt ( $\frac{7}{8}$ in. U.H.) ... ..	4	4	4
33	S26-2	Spring washer ... ..	4	4	4
34	D374	Check wire ... ..	1	1	1
35	F4483	Self tapping screw ... ..	1	1	1
36	F4226	Seat catch plunger ... ..	1	1	1
37	F4228	Spring ... ..	1	1	1
38	E1719A	Plain washer ... ..	1	1	1
39	$\frac{3}{32}$ in. x $\frac{1}{2}$ in.	Split pin ... ..	1	1	1
40	F4227	Knob ... ..	1	1	1
41	F4361	Safety strap ... ..		as required	
42	F4365	Self tapping screw ... ..	4	4	4

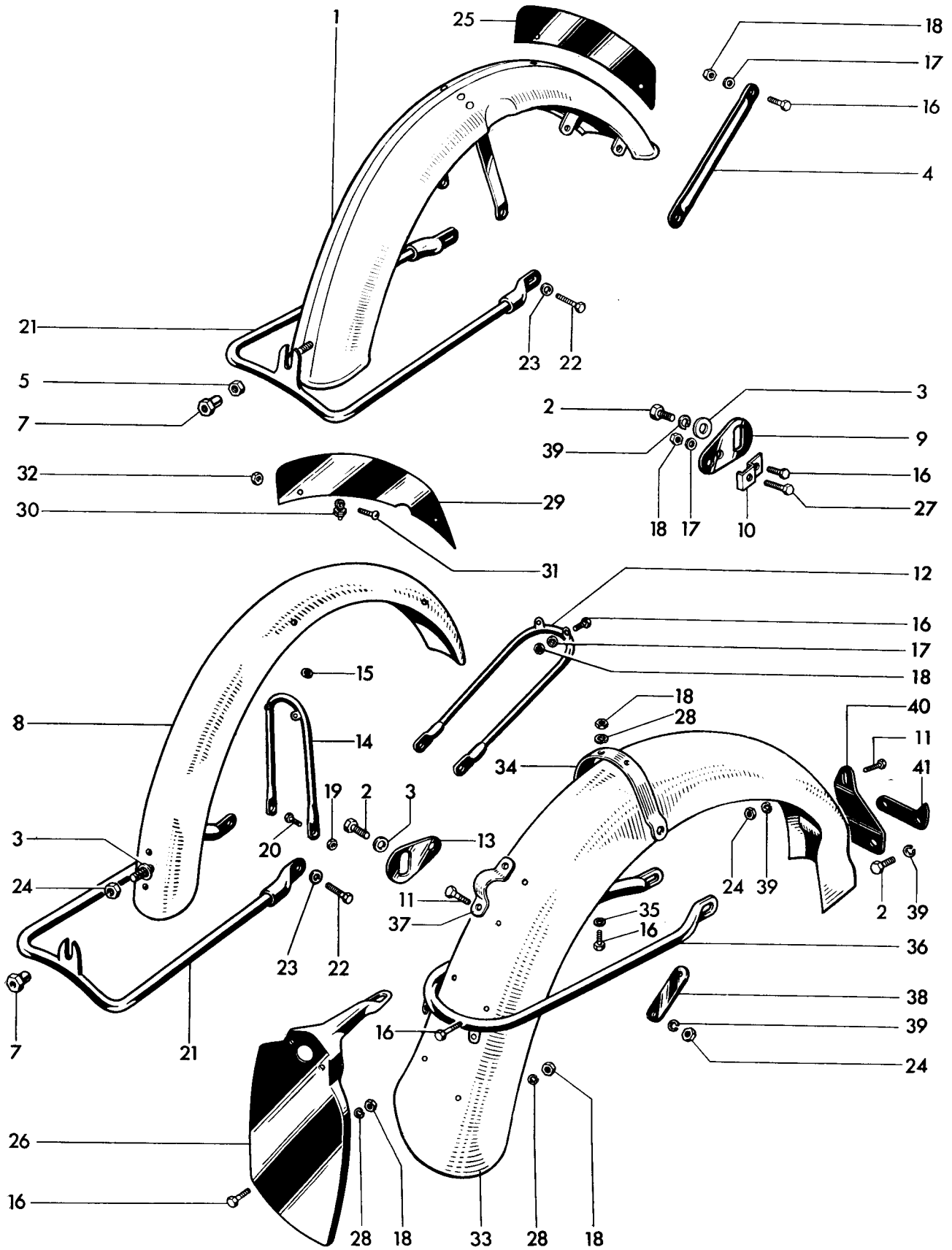

Fig. 26. MUDGUARDS

Ref. No.	Part No.	DESCRIPTION	QUANTITY		
<b>MUDGUARDS</b>					
			6T	TR6	T120
1	H1901	Front mudguard	1	-	-
2	F929	Bolt ( $\frac{1}{2}$ in. U.H.)	4	4	4
3	F4299	Plain washer	4	5	5
4	H1964	Front stay	2	-	-
5	H1904	Nut	1	-	-
6	S25-3	Plain washer	2	-	-
7	NS362	Spigot nut	1	1	1
8	H1675	Mudguard blade	-	1	1
9	H1878	Bracket	2	-	-
10	H1879	Clip	2	-	-
11	H590	Bolt ( $\frac{9}{16}$ in. U.H.)	3	3	3
12	H1681	Front stay	-	1	1
13	H1685	Bracket	-	2	2
14	H1683	Mudguard bridge	-	1	1
15	WE170	Fibre washer	-	2	2
16	DS57	Bolt ( $\frac{7}{16}$ in. U.H.)	10	10	10
17	S25-1	Plain washer	6	5	5
18	F879	Nut	17	10	10
19	T224	Nut	-	2	2
20	DS55	Bolt ( $\frac{5}{8}$ in. U.H.)	-	2	2
21	H1482	Bottom stay	1	1	1
22	H424	Bolt ( $\frac{3}{8}$ in. U.H.)	2	2	2
23	S25-71	Plain washer	2	2	2
24	S1-51	Nut	1	4	4
25	F6469	Number plate	1	-	-
26	F5924	Number plate	1	1	1
27	F1639	Bolt (in. U.H.)	2	-	-
28	S26-2	Spring washer	10	4	4
29	F6470	Number plate	-	1	1
30	H741	Clip assembly	2	2	2
31	H687	Screw ( $\frac{3}{8}$ in. U.H.)	2	2	2
32	H745	Nut	2	2	2
33	F5953	Mudguard blade	1	-	-
33	F5984	Mudguard blade	-	1	1
34	F4860	Mudguard bridge	1	1	1
35	F4299	Plain washer	2	2	2
36	F5424	Lifting handle	1	1	1
37	F5994	Clip	1	1	1
38	F6031	Backing plate	1	1	1
39	S26-3	Spring washer	9	5	5
40	F5369	Bracket	1	1	1
41	F5415	Inflator bracket	1	1	1

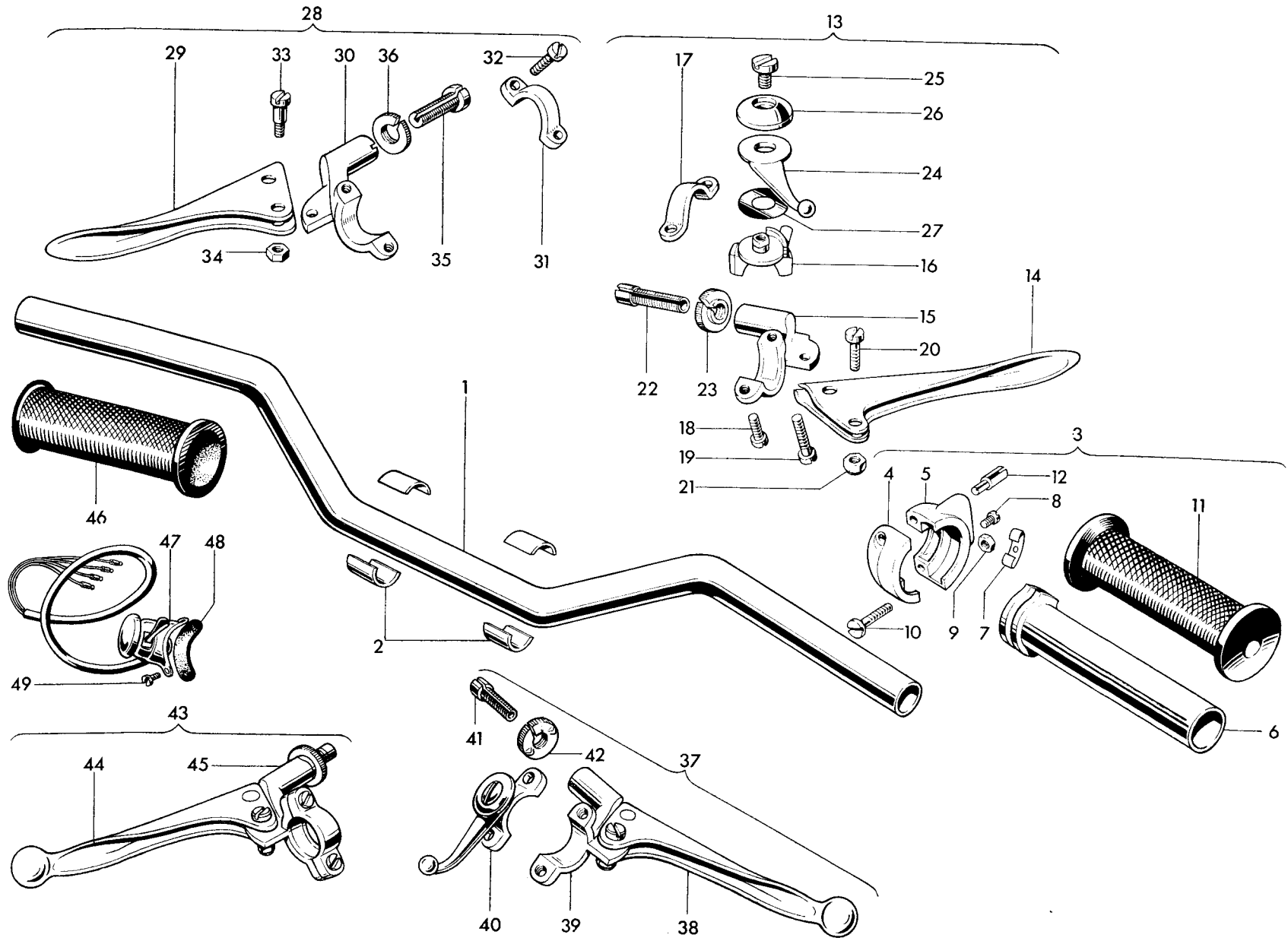

Fig. 27. HANDLEBARS AND CONTROL LEVERS

Ref. No.	Part No.	DESCRIPTION	QUANTITY	6T	TR6	T120
<b>HANDLEBARS AND CONTROL LEVERS</b>						
1	H.1871	Handlebar ... ..	1	1	1	
2	H.1425	Packing piece ... ..	4	4	4	
3	16/417	TWISTGRIP ... ..	1	1	1	
4	16/328	Body top half ... ..	1	1	1	
5	16/329	Body bottom half ... ..	1	1	1	
6	16/091	Rotor ... ..	1	1	1	
7	16/008	Friction spring ... ..	1	1	1	
8	16/009	Friction spring screw ... ..	1	1	1	
9	16/010	Locknut ... ..	1	1	1	
10	11/013	Screw ... ..	2	2	2	
11	16/070	Grip ... ..	1	1	1	
12	16/011	Cable stop ... ..	1	1	1	
13	18/1004	FRONT BRAKE AND AIR LEVER ASSEMBLY ... ..	1	-	-	
13	18/999	FRONT BRAKE LEVER ASSEMBLY ... ..	-	-	1	
14	18/535	Brake lever ... ..	1	-	1	
15	18/1014	Lever bracket ... ..	1	-	-	
15	18/1013	Lever bracket ... ..	-	-	1	
16	12/619	Control body ... ..	1	-	-	
17	12/595	Clamp ... ..	-	-	1	
18	11/014	Screw ... ..	1	1	2	
19	11/013	Screw ... ..	1	1	-	
20	18/087	Fulcrum screw ... ..	1	1	1	
21	18/053	Self locking nut ... ..	1	1	1	
22	18/1005	Cable adjuster ... ..	1	-	1	
23	18/1006	Thumb nut ... ..	1	-	1	
24	12/556	Lever ... ..	1	1	-	
25	12/607	Bolt ... ..	1	1	-	
26	12/606	Cap ... ..	1	1	-	
27	12/033	Spring washer ... ..	1	1	-	
28	18/1000	CLUTCH LEVER ASSEMBLY ... ..	1	-	1	
29	18/528	Clutch lever ... ..	1	-	1	
30	18/1009	Clutch lever bracket ... ..	1	-	1	
31	12/595	Clamp ... ..	1	-	1	
32	11/014	Screw ... ..	2	-	2	
33	18/087	Fulcrum screw ... ..	1	-	1	
34	18/053	Self locking nut ... ..	1	-	1	
35	18/1005	Cable adjuster ... ..	1	-	1	
36	18/1006	Thumb nut ... ..	1	-	1	
37	18/978	FRONT BRAKE AND AIR LEVER ASSEMBLY ... ..	-	1	-	
38	18/754	Brake lever (ball end) ... ..	-	1	-	
39	18/776	Lever bracket ... ..	-	1	-	
40	12/594	Control body ... ..	-	1	-	
41	18/838	Cable adjuster ... ..	-	2	-	
42	18/839	Thumb nut ... ..	-	2	-	
43	18/952	CLUTCH LEVER ASSEMBLY ... ..	-	1	-	
44	18/752	Clutch lever (ball end) ... ..	-	1	-	
45	18/773	Lever bracket ... ..	-	1	-	
46	16/069	Handlebar grip ... ..	1	1	1	
47	31563	Horn push and dip switch ... ..	1	1	1	
48	380459	Backing rubber ... ..	1	1	1	
49	H.1876	Screw (½ in. U.H.) ... ..	2	2	2	



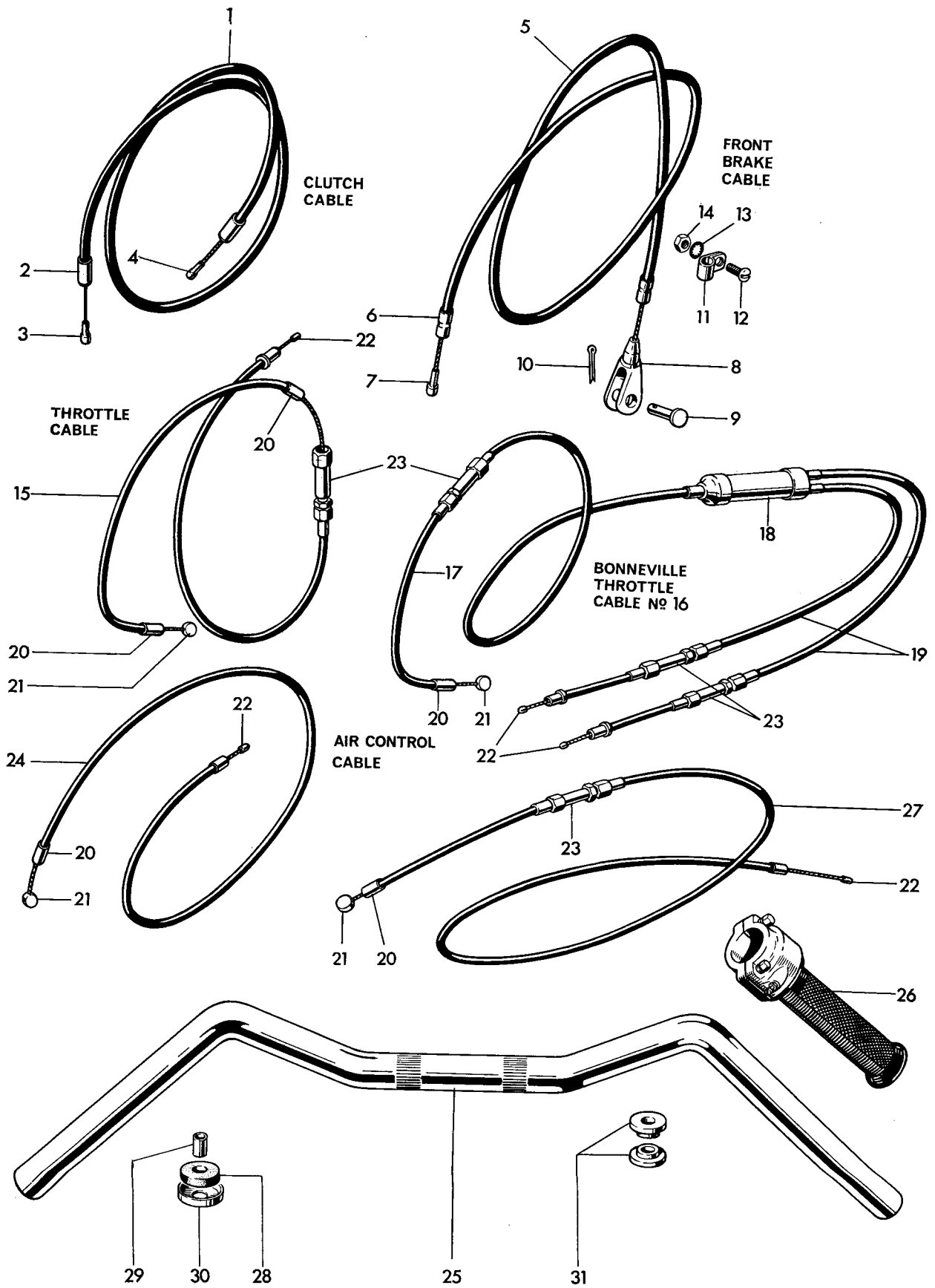

Fig. 28. CONTROL CABLES AND AMERICAN HANDLEBARS

**CONTROL CABLES AND AMERICAN HANDLEBARS**

			6T	TR6	T120
1	D565	CLUTCH CABLE ... ..	1	1	1
2	D103	Ferrule ... ..	2	2	2
3	D506	Nipple (Handlebar end) ... ..	1	1	1
4	DS73	Nipple ... ..	1	1	1
5	D558	FRONT BRAKE CABLE ... ..	1	1	1
6	D103	Ferrule ... ..	2	2	2
7	D506	Nipple (Handlebar end) ... ..	1	1	1
8	W593	Fork end ... ..	1	1	1
9	WF32	Pivot pin... ..	1	1	1
10	$\frac{1}{16}$ in. x $\frac{5}{8}$ in.	Split pin ... ..	1	1	1
11	H1171	Clip ... ..	1	-	-
12	F4715	Screw ( $\frac{13}{32}$ in. U.H.) ... ..	1	-	-
13	GS299	Serrated washer ... ..	1	-	-
14	H745	Nut ... ..	1	-	-
15	D495	THROTTLE CABLE ... ..	1	-	-
15	D519	THROTTLE CABLE ... ..	-	1	-
16	D499	THROTTLE CABLE ... ..	-	-	1
17	D500	Twistgrip cable ... ..	-	-	1
18	244/104	Junction block ... ..	-	-	1
19	D423	Carburettor cable ... ..	-	-	2
20	D101	Ferrule ... ..	3	3	10
21	D83	Nipple ... ..	1	1	1
22	NS191	Nipple ... ..	1	1	5
23	D104	Adjuster ... ..	1	1	3
24	D435	Air control cable ... ..	1	-	-
24	D507	Air control cable ... ..	-	1	-
25	H1869	American handlebar ... ..	1	-	-
25	H1870	American handlebar ... ..	-	1	1
5	D559	Front brake cable ... ..	1	1	1
16	D515	Throttle cable ... ..	-	-	1
26	313/6	Twin rotor twistgrip ... ..	-	-	1
27	D528	Throttle cable ... ..	-	-	2
28	H1580	Steady rubber ... ..	2	2	2
29	H1581	Distance piece ... ..	2	2	2
30	F3814	Cup ... ..	2	2	2
31	H1616	Solid bush (for handlebar-mounted windscreen) ... ..	4	4	4

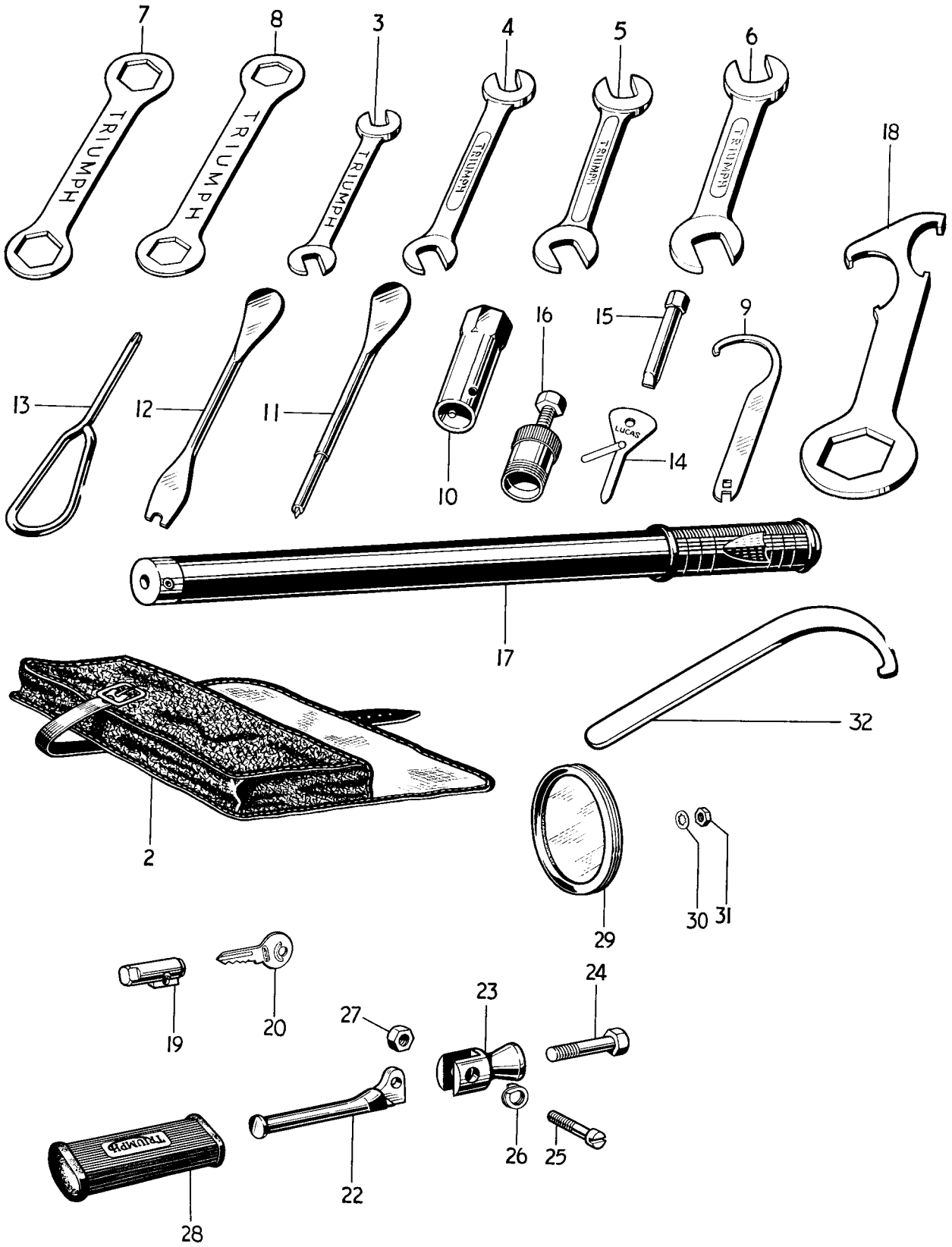

Fig. 29. TOOLKIT, FRAME LOCK, PILLION FOOTRESTS AND LICENCE HOLDER

Ref. No.	Part No.	DESCRIPTION	QUANTITY
----------	----------	-------------	----------

**TOOLKIT, FRAME LOCK, PILLION FOOTRESTS AND LICENCE HOLDER**

			6T	TR6	T120
1	D365	TOOLKIT COMPLETE	1	1	1
2	WA58	Tool roll	1	1	1
3	D360	Open spanner, $\frac{1}{8} \times \frac{5}{32}$ in. Whit.	1	1	1
4	D361	Open spanner, $\frac{3}{16} \times \frac{1}{4}$ in. Whit.	1	1	1
5	NA55	Open spanner, $\frac{1}{4} \times \frac{5}{16}$ in. Whit.	1	1	1
6	DA16	Open spanner, $\frac{3}{8} \times \frac{7}{16}$ in. Whit.	1	1	1
7	PA57	Ring spanner, $\frac{1}{2} \times \frac{9}{16}$ in. Whit.	1	1	1
8	D311	Ring spanner, $\frac{5}{8} \times \frac{11}{16}$ in. Whit.	1	1	1
9	D362	"C" spanner and tappet key	1	1	1
10	D87	Plug spanner	1	1	1
11	D363	Tyre lever and screwdriver	1	1	1
12	D364	Tyre lever and clutch key	1	1	1
13	D336	Phillips No. 3 screwdriver	1	1	1
14	400935	Screwdriver	1	1	1
15	D496	Screwdriver for chain tensioner	1	1	1
16	DA50/1	Clutch hub extractor	A	A	A
17	D296	Tyre inflator	1	1	1
18	D220	Fork spanner (for cap nut)	A	A	A
19	D402/3	FRAME LOCK c/w KEYS	1	1	1
20	D403	Key (state number)	1	1	1
21	F5552	PILLION FOOTREST	2	2	2
22	F1694	Pedal	2	2	2
23	F2268	Hanger	2	2	2
24	F5535	Bolt ( $\frac{13}{16}$ in. U.H.)	2	2	2
25	F2271	Pivot bolt	2	2	2
26	F2277	Thackeray (spring) washer	2	2	2
27	S1-51	Nut	2	2	2
28	F1695	Pedal rubber	2	2	2
29	D261	Licence holder	1	1	1
30	E1612	Serrated washer	1	-	-
31	F879	Nut	1	-	-
32	D527	Fork spanner (for sleeve nut)...	A	A	A



Ref. No.	Part No.	DESCRIPTION	QUANTITY
----------	----------	-------------	----------

**AMAL CARBURETTER 6T**

			6T
1	376/303	CARBURETTER ... ..	1
2	376/003	Mixing chamber, 1 $\frac{1}{16}$ in. choke	1
3	244/1048	"O" ring seal	1
4	376/065	Mixing chamber cap	1
5	29/307	Spring	1
6	4/241	Screw	1
7	376/107	Mixing chamber top	1
8	376/062	Air valve	1
9	4/046	Spring	1
10	6/047	Air valve guide	1
11	6/132A	Throttle cable ferrule	1
12	4/035	Air cable adaptor	1
13	376/060	Throttle valve (state cutaway)	1
14	376/061	Throttle return spring	1
15	376/068	Throttle stop screw	1
16	376/069	Stop screw spring	1
17	376/070	Peg screw	1
18	376/057	Jet block (1 $\frac{1}{16}$ in. choke)	1
19	376/067	Joint washer	1
20	376/073	Jet holder	1
21	376/074	Fibre washer	1
22	376/100	Main jet (state size)	1
23	376/075	Cover nut	1
24	376/072	Needle jet (0.106)...	1
25	376/063	Needle (Type C)	1
26	4/230	Needle clip	1
27	376/076	Pilot jet (state size)	1
28	116/017	Fibre washer	1
29	376/095	Cover nut	1
30	332/017	Air adjusting screw	1
31	4/148	Spring	1
32	376/085	Float spindle	1
33	376/083	Float	1
34	376/094	Bush	1
35	376/078	Joint washer	1
36	376/077	Cover	3
37	376/079	Screw	1
38	376/088	Needle seating	1
39	376/089	Needle	1
40	376/093	Filter	1
41	376/091	Bolt	1
42	376/092	Fibre washer	1
43	376/086	Tickler	1
44	376/087	Tickler spring	1
45	343/011	Tickler body	1
46	F5339	Petrol pipe	1

CARBURETTER COMPLETE  
REFERENCE N°1

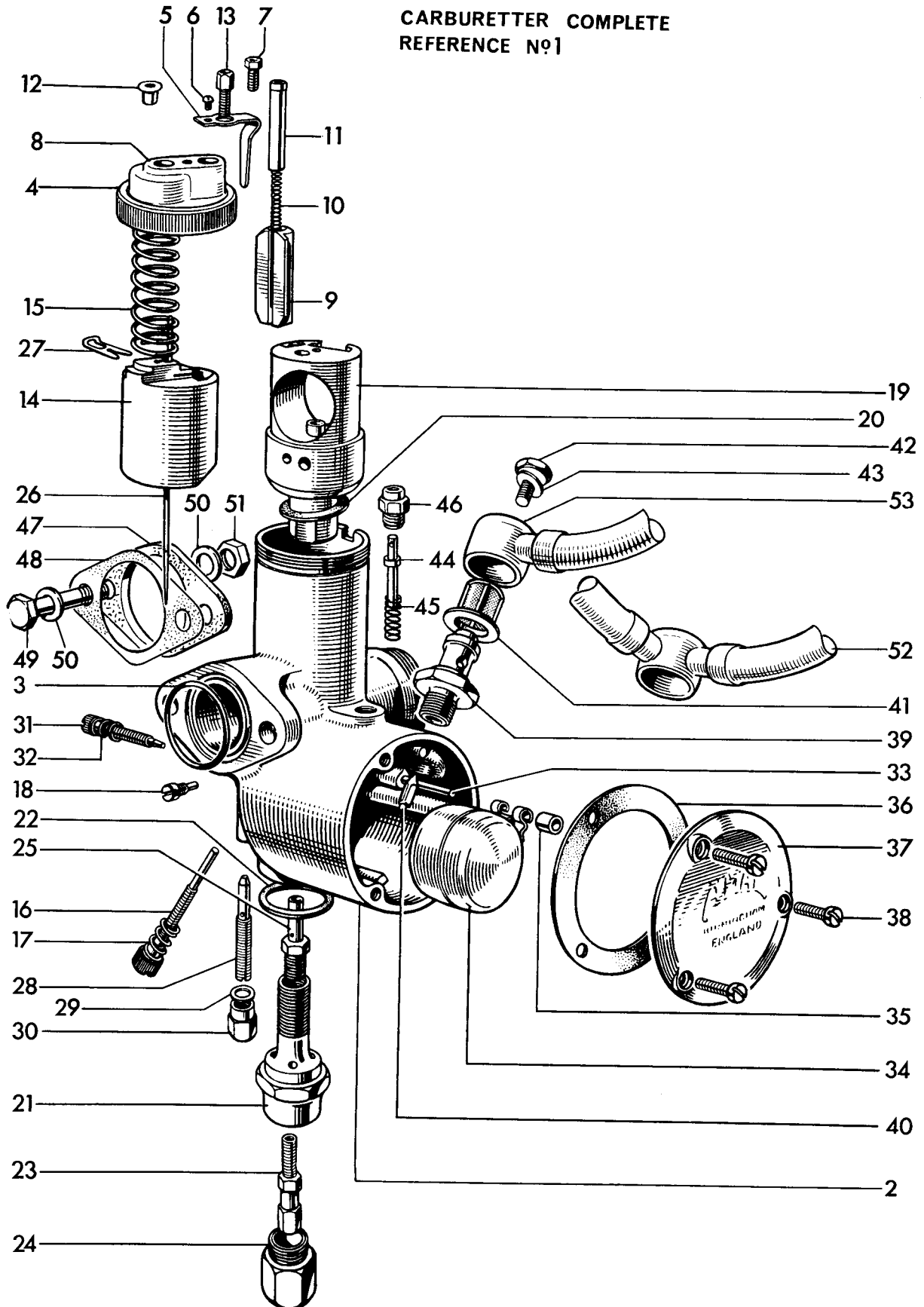

Fig. 31. AMAL CARBURETTER, TR6 AND T120

Ref. No.	Part No.	DESCRIPTION	QUANTITY	
<b>AMAL CARBURETTER, TR6 &amp; T120</b>				
			TR6	T120
1	389/97	CARBURETTER ... ..	1	-
1	389/203	CARBURETTER ... ..	-	2
2	389/002	Mixing chamber (1 $\frac{1}{8}$ in. choke) ... ..	1	2
3	244/1048	"O" ring seal ... ..	1	2
4	389/065	Mixing chamber cap ... ..	1	2
5	29/307	Spring ... ..	1	2
6	4/241	Screw ... ..	1	2
7	4/137A	Plug screw ... ..	-	2
8	389/107	Mixing chamber top ... ..	1	2
9	389/062	Air valve ... ..	1	-
10	4/046	Spring ... ..	1	-
11	29/057	Air valve guide ... ..	1	-
12	6/132A	Throttle cable ferrule ... ..	1	2
13	4/035	Air cable adjuster ... ..	1	-
14	389/060	Throttle valve (state cutaway) ... ..	1	2
15	389/061	Throttle return spring ... ..	1	2
16	376/068	Throttle stop screw ... ..	1	2
17	376/069	Stop screw spring ... ..	1	2
18	376/070	Peg screw ... ..	1	2
19	389/056	Jet block (1 $\frac{1}{8}$ in. choke) ... ..	1	2
20	376/067	Joint washer ... ..	1	2
21	376/073	Jet holder ... ..	1	2
22	376/074	Fibre washer ... ..	1	2
23	376/100	Main jet (state size) ... ..	1	2
24	376/075	Cover nut ... ..	1	2
25	376/072	Needle jet (0.106)... ..	1	2
26	389/063	Needle (Type D) ... ..	1	2
27	4/230	Needle clip ... ..	1	2
28	376/076	Pilot jet (state size) ... ..	1	2
29	116/162	Fibre washer ... ..	1	2
30	376/095	Cover nut ... ..	1	2
31	332/017	Air adjusting screw ... ..	1	2
32	4/148	Spring ... ..	1	2
33	376/085	Float spindle ... ..	1	2
34	376/083	Float ... ..	1	2
35	376/094	Bush ... ..	1	2
36	376/078	Joint washer ... ..	1	2
37	376/077	Cover ... ..	1	2
38	376/079	Screw ... ..	3	-
38	376/151	Screw ... ..	-	6
39	376/088	Needle seating ... ..	1	2
40	376/089	Needle ... ..	1	2
41	376/093	Filter ... ..	1	2
42	376/091	Bolt ... ..	1	2
43	376/092	Fibre washer ... ..	1	2
44	376/086	Tickler ... ..	1	2
45	376/087	Tickler spring ... ..	1	2
46	343/011	Tickler body ... ..	1	2
47	E2968	Insulating block ... ..	-	2
48	NA43A	Joint washer ... ..	-	2
49	F2603	Bolt (1 $\frac{5}{8}$ in. U.H.) ... ..	-	4
50	S25-3	Plain washer ... ..	-	4
51	T224	Nut ... ..	-	4
52	F5339	Petrol pipe ... ..	1	-
53	F5462	Petrol pipe ... ..	-	1



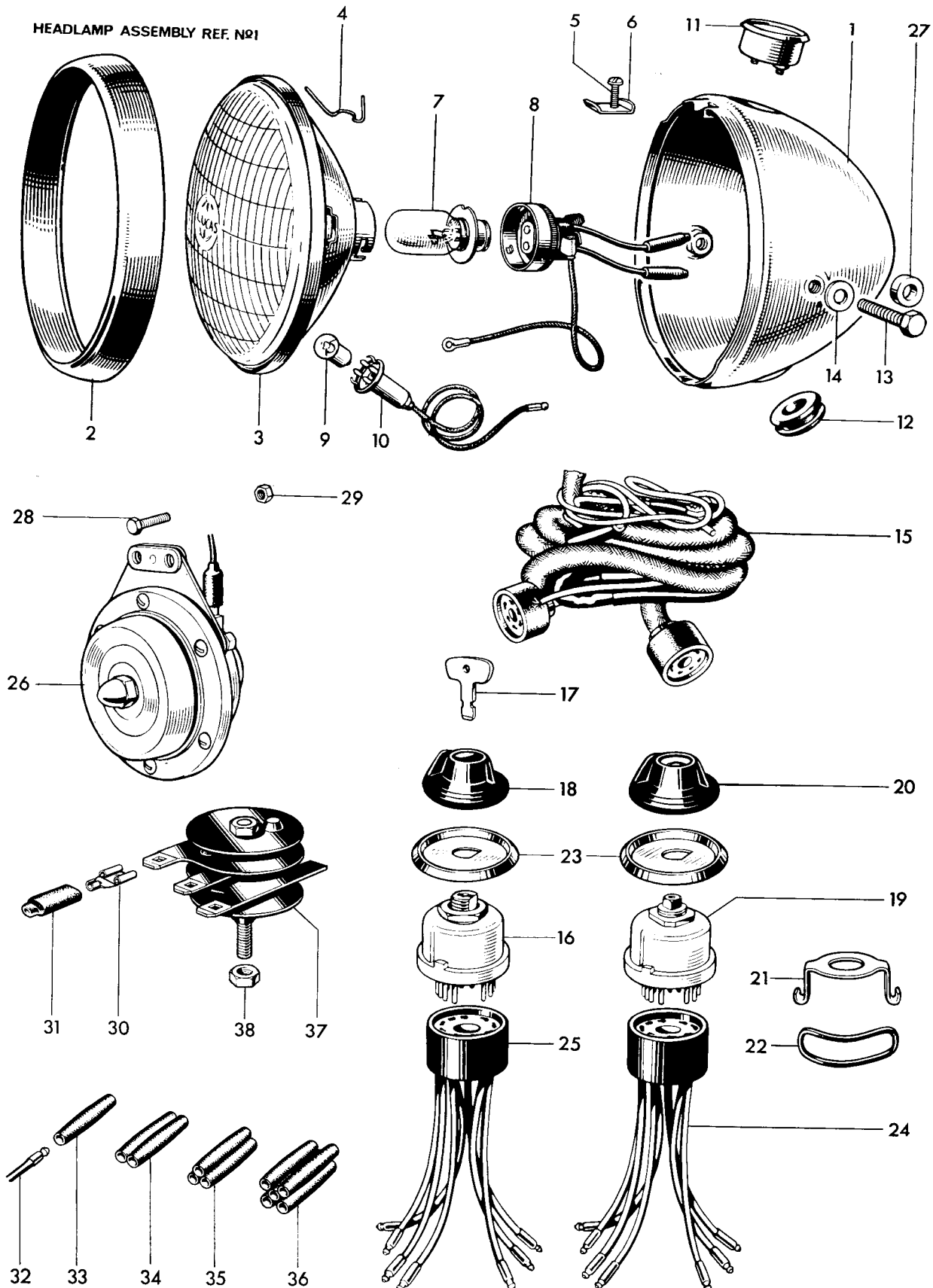

Fig. 32. HEADLAMP, WIRING HARNESS, HORN AND RECTIFIER

### HEADLAMP, WIRING HARNESS, HORN AND RECTIFIER

			6T	TR6	T120
1	58934	HEADLAMP COMPLETE	-	1	1
2	553248	Rim	-	1	1
3	516798	Light unit	-	1	1
4	504665	Fixing wire...	-	6	6
5	144921	Screw	-	1	1
6	534296	Plate	-	1	1
7	312	Bulb (30/24 W. Vert dip. Pre-focus)	-	1	1
8	554602	Main bulbholder	-	1	1
9	988	Bulb (3W. M.C.C.)	-	1	1
10	554710	Pilot bulbholder	-	1	1
11	36296	Ammeter, type 2AR	-	1	1
12	862217	Grommet	-	1	1
13	112201	Bolt	-	2	2
14	137499	Plain washer	-	2	2
15	54936415	Wiring harness	-	1	1
16	34427	IGNITION SWITCH COMPLETE WITH KEY, type 88SA	-	1	1
17	54336176	Ignition key	-	1	1
18	54336178	Ignition switch cover	-	1	1
19	34289	Lighting switch, type 88SA	-	1	1
20	54330934	Knob c/w screw	-	1	1
21	F5983	Bracket	-	2	2
22	F5988	Rubber band	-	2	2
23	54330576	Switch bezel plate	-	2	2
24	54930007	Replacement harness socket (Lighting)	-	1	1
25	54930008	Replacement harness socket (ignition)	-	1	1
26	70163	Horn, type 8H	-	1	1
27	H1932	Headlamp spacer	-	2	2
28	F4771	Screw ( $\frac{3}{8}$ in. U.H.)	-	2	2
29	F3799	Nut	-	2	2
30	54942078	Lucar connector	5	5	5
31	54190042	Insulating cover...	5	5	5
32	900269	Snap connector terminal		as required	
33	900288	Single snap connector		as required	
34	850641	Double snap connector		as required	
35	850844	Triple snap connector		as required	
36	850832	Quintuple snap connector		as required	
37	49072	Rectifier, type 2DS 506	1	1	1
38	F5338	Nut (156 596)	1	1	1

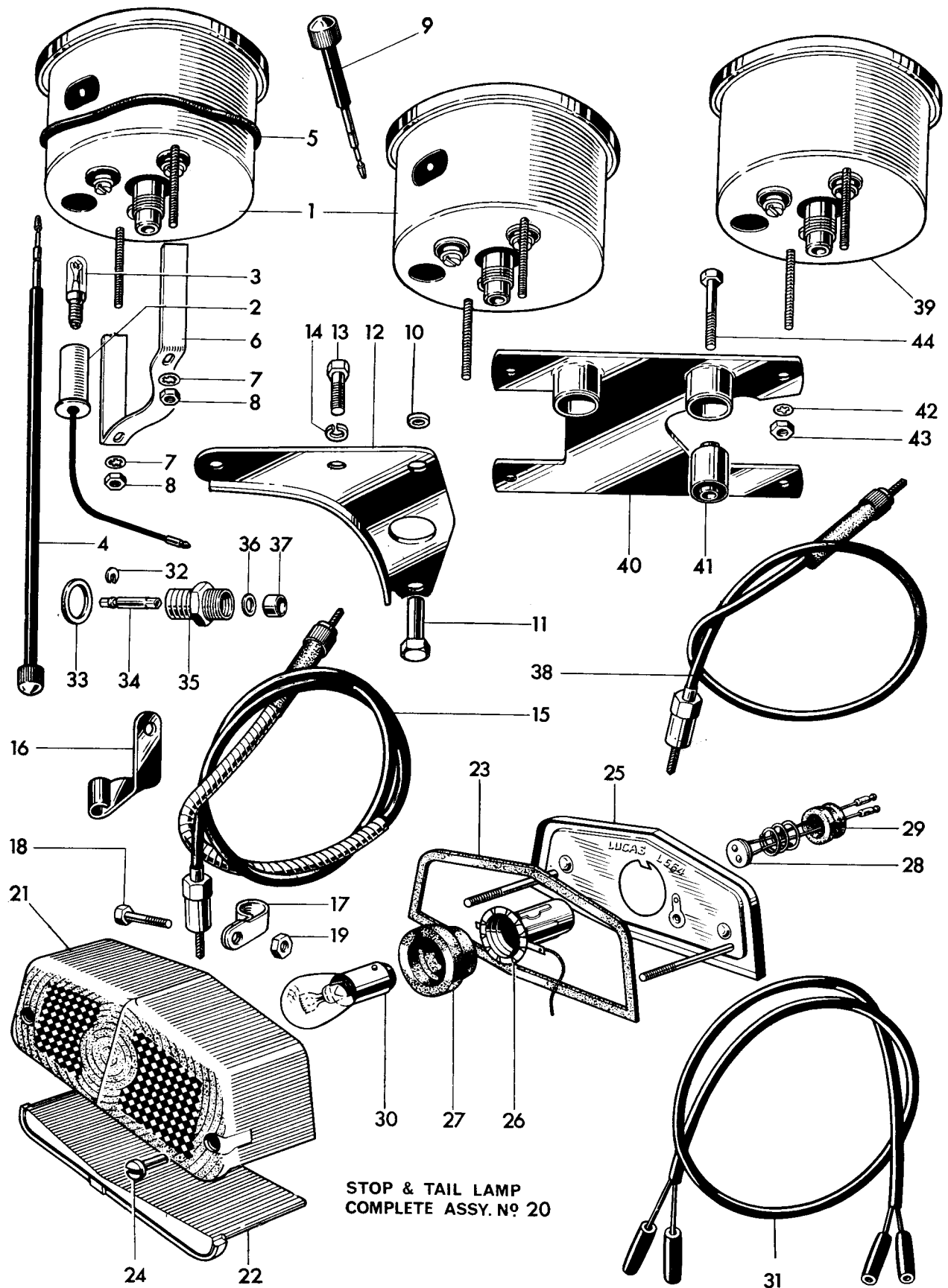

Fig. 33. SPEEDOMETER TACHOMETER AND TAIL LAMP

Ref. No.	Part No.	DESCRIPTION	QUANTITY		
<b>SPEEDOMETER, TACHOMETER AND TAIL LAMP</b>					
			6T	TR6	T120
1	SSM5002/00	Speedometer head MPH	1	-	-
1	SSM5002/01	Speedometer head KPH	A	-	-
1	SSM5001/00	Speedometer head MPH	-	1	-
1	SSM5001/01	Speedometer head KPH	-	A	A
2	554734	Bulb holder	1	1	1
3	987	Bulb, 3.W. M.E.S.	1	-	-
3	990	Bulb, 3.W. M.E.S.	-	1	1
4	41-118-127-72	Trip control	1	-	-
5	31-753-778	Rubber ring	1	-	-
6	31-674-188-01	Fixing strap	1	-	-
7	30-283-014-11	Washer	2	-	-
8	30-277-023-11	Nut	2	-	-
9	41-148-203-10	Trip control	-	1	1
10	H1702	Distance piece	-	2	2
11	H1701	Sleeve nut	-	2	2
12	H1668	Bracket	-	1	1
13	DS57	Bolt ( $\frac{7}{8}$ in. U.H.)	-	2	2
14	S26-2	Spring washer	-	2	2
15	D542	Speedometer cable (44 ins. long)	1	-	-
15	D543	Speedometer cable (40 $\frac{1}{2}$ ins. long)	-	1	1
16	H1698	Cable bracket	1	-	-
17	F3098	Clip	1	1	1
18	F1718	Bolt (1 $\frac{3}{8}$ in. U.H.)	1	1	1
19	S1-51	Nut	1	1	1
20	53454	STOP AND TAIL LAMP (type 564)	1	-	-
20	53432	STOP AND TAIL LAMP (type 564)	-	1	1
21	573839	Lens...	1	1	1
22	575200	Window	1	1	1
23	575208	Lens seating gasket	1	1	1
24	575219	Sleeve nut	2	2	2
25	576002	Base assembly	1	1	1
26	575209	Bulb holder	1	1	1
27	575207	Grommet	1	1	1
28	573828	Contact assembly	1	1	1
29	573825	Grommet	1	1	1
30	380	Bulb (6/21W. Offset pin)	1	-	-
30	384	Bulb (6/18W. Offset pin)	-	1	1
31	838604	Stop and tail lamp lead	1	1	1
32	D494	Circlip	1	1	1
33	T1257	Fibre washer	-	1	1
34	D493	Spade	-	1	1
35	E5667	ADAPTOR	-	1	1
36	E4803	"O" ring	-	1	1
37	E5669	Nylon bush	-	1	1
38	D529	Tachometer cable (34 $\frac{1}{2}$ in. long)	-	1	1
39	RSM 3001/02	Tachometer	-	1	1
40	H1596	MOUNTING BRACKET	-	2	2
41	H1087	Metalastik bush	-	4	4
42	30-282-014-11	Washer	-	4	4
43	30-276-037-11	Nut	-	2	2
44	H1086	Bolt (1 $\frac{3}{8}$ in. U.H.)	-	-	-

*Printed in England by*  
WARWICK PRINTING COMPANY LTD.  
WARWICK