



REPLACEMENT PARTS

CATALOGUE No. 2

UNIT CONSTRUCTION 650 c.c. TWINS

6T THUNDERBIRD

TR6 TROPHY

T120 BONNEVILLE 120

From engine No. DU 5825

[See Bookmarks](#)

TRIUMPH ENGINEERING COMPANY LIMITED
MERIDEN WORKS · ALLESLEY · COVENTRY · ENGLAND
TELEPHONE MERIDEN 331
COVENTRY 20221

TELEGRAMS "TRUSTY COVENTRY"

PUBLICATION PART No. 99-0821

TRIUMPH GUARANTEE

1. In this Guarantee the word "machine" refers to the motor cycle, scooter, motor cycle combination or sidecar as the case may be, purchased by the Purchaser.
2. In order to obtain the benefit of this Guarantee, the Purchaser must have correctly completed the registration form and returned it to us within fourteen days of the purchase.
3. We will supply, free of charge, a new part in exchange for, or, if we consider repair sufficient, will repair free of charge any part proved within six months of the date of purchase of any new machine, (three months overseas) or within three months of its renewal or repair in the case of a part already renewed or repaired, to be defective by reason of our faulty workmanship or materials. We do not undertake to bear the cost of fitting such new or repaired part or accessory.
4. Any part considered to be defective must be sent to our Works, carriage paid, accompanied by the following information:—
 - (a) Name of purchaser and his address;
 - (b) Date of purchase of machine;
 - (c) Name of dealer from whom the purchase was made;
 - (d) Engine number and model.
5. This Guarantee shall not extend to defects or damage appearing after misuse, neglect, abnormal stress or strain, or the incorporation or affixing of unsuitable attachments or parts and in particular:—
 - (a) Hiring out;
 - (b) Racing and Competitions;
 - (c) Adaptation or alteration of any part or parts after leaving our Works;
 - (d) The attaching of a sidecar in a manner not approved by us or to an unsuitable motor cycle.

This Guarantee shall not extend to machines whose trade mark, name or manufacturing number has been altered or removed, or in which has been used any part not supplied or approved by us, or to tyres, saddles, chains, speedometers, revolution counters and electrical equipment or to parts supplied to the order of the Purchaser and different from our standard specification.
6. Our liability and that of our dealer who sells the machine, shall be limited to that set out in this guarantee, and no other claims including claims for consequential damage or injury to person or property, shall be admissible. All other conditions and warranties statutory or otherwise and whether express or implied are hereby excluded and no guarantee other than that expressly herein contained applies to the machine to which this Guarantee relates or any accessory or part thereof.
7. We reserve the right to modify or deviate from the Published Specification without notice.

REPAIRS GUARANTEE

1. Whilst the highest standard of workmanship and materials is aimed at, we cannot accept liability for any defects appearing more than three months after the machine, assembly or component has left our Works after being repaired.
2. We will repair or replace at our option free of charge any defective work, materials or parts relating to the repairs carried out by us appearing within that time but shall not be under any further or other liability for any other loss or damage whether direct or consequential and our liability shall be limited to the cost of so making good. We do not undertake to bear the cost of fitting any replacement or repaired part.
3. We do not accept liability in respect of parts of proprietary manufacture, e.g. tyres, saddles, chains, speedometers, revolution counters and electrical equipment which may be used by us in effecting a repair. All other conditions and warranties statutory or otherwise express or implied are hereby excluded.

ILLUSTRATION INDEX

<i>Fig. No.</i>	<i>Description</i>	<i>Page No.</i>
1	CRANKSHAFT AND CONNECTING RODS	12
2	CRANKCASE	14
3	OIL PUMP AND RELEASE VALVE AND MANIFOLD	16
4	CYLINDER BLOCK AND HEAD, 6T AND TR6	18
5	CYLINDER BLOCK AND HEAD, T120	20
6	TIMING COVER, CONTACT BREAKER AND COILS	22
7	GEARBOX INNER COVER AND SELECTORS	24
8	GEARBOX SHAFTS AND GEARS	26
9	GEARBOX OUTER COVER	28
10	CLUTCH	30
11	CHAINCASE AND CHAINS	32
12	FRAME	34
13	SWINGING FORK AND SUSPENSION UNITS	36
14	ENGINE UNIT FITTINGS AND FOOTRESTS	38
15	EXHAUST PIPES AND SILENCERS	40
16	TELESCOPIC FRONT FORKS, 6T	42
17	NACELLE HEADLAMP AND SWITCHES	44
18	TELESCOPIC FRONT FORK, TR6 AND T120	46
19	FRONT WHEEL	48
20	REAR WHEEL	50
21	QUICKLY DETACHABLE REAR WHEEL	52
22	PETROL TANKS	54
23	OIL TANK	56
24	BATTERY CARRIER AND AIR FILTER	58
25	PANELS AND TWINSEAT	60
26	MUDGUARDS	62
27	HANDLEBARS AND CONTROL LEVERS	64
28	CONTROL CABLES AND AMERICAN HANDLEBARS	66
29	TOOLKIT, FRAME LOCK, PILLION FOOTRESTS AND LICENCE HOLDER	68
30	AMAL CARBURETTER, 6T	70
31	AMAL CARBURETTER, TR6 AND T120	72
32	HEADLAMP, WIRING HARNESS, HORN AND RECTIFIER	74
33	SPEEDOMETER, TACHOMETER AND TAIL LAMP	76

INDEX

	<i>Page</i>		<i>Page</i>
AIR FILTER	59	MANIFOLD	17
ALTERNATOR	13, 33	MUDGUARDS	63
BATTERY CARRIER	59	NACELLE	45
CARBURETTER	71, 73	OIL PUMP	17
CARTON PACKS	9	OIL TANK	57
CENTRE STAND	35	PETROL TANK	55
CHAINCASE	33	PILLION FOOTRESTS	69
CHAINS	33	PISTONS	13
CLUTCH	31	PROP STAND	35
COIL	23	Q.D. REAR WHEEL	53
CONTACT BREAKER	23	REAR PANELS	61
CONTROL CABLES	67	REAR WHEEL	51
CONTROL LEVERS	65	RECTIFIER	75
CRANKCASE	15	SILENCERS	41
CRANKSHAFT	13	SPARK PLUGS	23
CYLINDER HEAD	19, 21	SPEEDOMETER	77
ENGINE PLATES	39	STEERING RACES	35
EXHAUST PIPES	41	SUSPENSION UNITS	37
FOOTRESTS	39	SWITCHES	37, 45, 75
FRONT FORKS	43, 47	TIMING GEARS	13
FRONT WHEEL	49	TOOLKIT	69
GASKET SETS	10	TWINSEAT	61
GEARBOX	25, 27, 29	VALVES	19, 21
HANDLEBARS	65	WIRING HARNESS	45, 75
HORN	45	ZENER DIODE	45

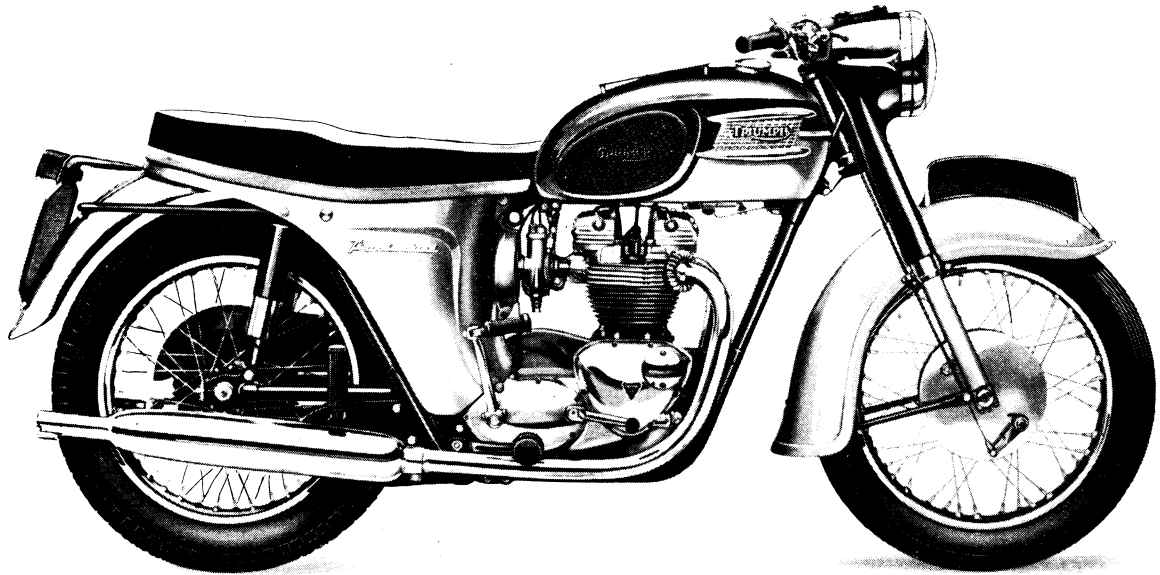

THUNDERBIRD (6T) TECHNICAL DATA

Bore and stroke	71×82 mm. 2.79×3.23 ins.
Capacity	649 c.c. (40 cu. ins.)
Compression ratio	7.5 : 1
Sparking plugs	Champion N4
Carburetter	Amal Monobloc 376
										Main jet ... 230
										Needle jet106
										Needle ... Type C
										Throttle valve ... 376/4
										Pilot jet ... 25
Gearbox sprocket							Solo ... 20 teeth
										Sidecar ... 18 teeth
Chains							Front ... $\frac{3}{8}$ " Duplex×84 links
										Rear ... Solo ... $\frac{5}{8}$ "× $\frac{3}{8}$ "×103 links
										Sidecar ... $\frac{5}{8}$ "× $\frac{3}{8}$ "×102 links
Capacities							Fuel Tank ... 4 galls. (18 litres)
										Oil Tank ... 5 pints (2.8 litres)
										Gearbox ... $\frac{7}{8}$ pint (500 c.c.)
										Primary Chaincase ... $\frac{5}{8}$ pint (350 c.c.)
										Front Forks (each leg) ... $\frac{1}{2}$ pint (190 c.c.)
Brakes							Front, diameter... 8" (20.32 cms.)
										Rear, diameter ... 7" (17.78 cms.)
Tyre size							Front ... 3.25×18
										Rear ... 3.50×18

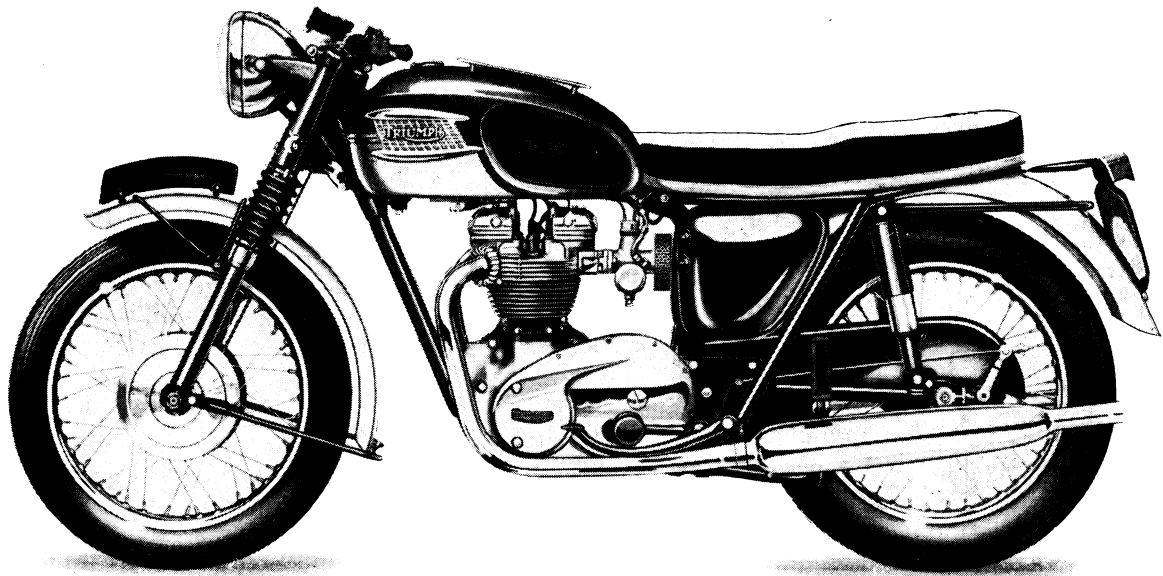

TROPHY (TR6) TECHNICAL DATA

Bore and stroke	71 × 82 mm. 2.79 × 3.23 ins.
Capacity	649 c.c. (40 cu. ins.)
Compression ratio	8.5 : 1
Sparking plugs	Champion N4
Carburetter	Amal Monobloc 389
										Main jet ... 310
										Needle jet106
										Needle ... Type D
										Throttle valve ... 389/3½
										Pilot jet ... 25
Gearbox sprocket	Solo	19 teeth
							Sidecar	17 teeth
Chains	Front	3/8" Duplex × 84 links
					Rear	Solo	...	5/8" × 3/8" × 103 links
								Sidecar	...	5/8" × 3/8" × 102 links
Capacities	Fuel Tank	4 galls. (18 litres)
					Oil Tank	5 pints (2.8 litres)
					Gearbox	7/8 pint (500 c.c.)
					Primary Chaincase	5/8 pint (350 c.c.)
					Front Forks (each leg)	1/2 pint (190 c.c.)
Brakes	Front, diameter...	8 in. (20.32 cm.)
					Rear, diameter	7 in. (17.78 cm.)
Tyre size	Front	3.25 × 19
					Rear	4.00 × 18

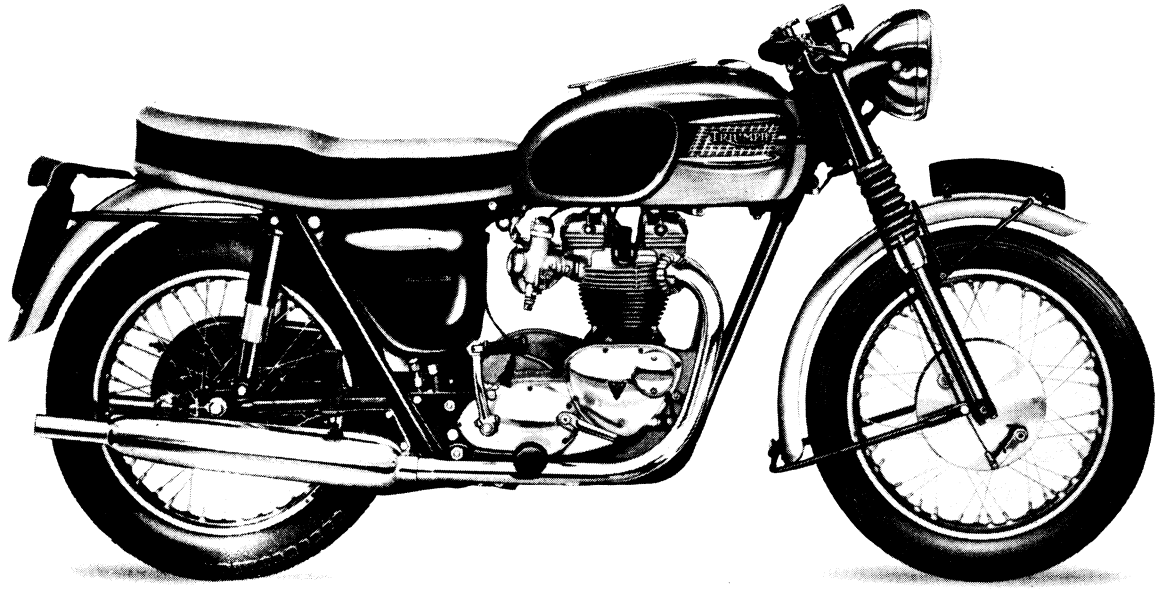

BONNEVILLE 120 (T120) TECHNICAL DATA

Bore and stroke	71 × 82 mm. 2.79 × 3.23 ins.
Capacity	649 c.c. (40 cu. ins.)
Compression ratio	8.5 : 1
Sparking plugs	Champion N4
Carburetters	2 Amal Monobloc 389
										Main jet ... 260
										Needle jet106
										Needle ... Type D
										Throttle valve ... 389/3
										Pilot jet ... 25
Gearbox sprocket	Solo	...	19 teeth
								Sidecar	...	17 teeth
Chains	$\frac{3}{8}$ " Duplex × 84 links
								Front	...	
								Rear	...	$\frac{5}{8}$ " × $\frac{3}{8}$ " × 103 links
								Solo	...	
								Sidecar	...	$\frac{5}{8}$ " × $\frac{3}{8}$ " × 102 links
Capacities	Fuel Tank ... 4 galls. (18 litres)
								Oil Tank	...	5 pints (2.8 litres)
								Gearbox	...	$\frac{7}{8}$ pint (500 c.c.)
								Primary Chaincase	...	$\frac{5}{8}$ pint (350 c.c.)
								Front Forks (each leg)	...	$\frac{1}{2}$ pint (190 c.c.)
Brakes	Front, diameter... 8 in. (20.32 cm.)
								Rear, diameter	...	7 in. (17.78 cm.)
Tyre size	Front ... 3.25 × 18
								Rear	...	3.50 × 18

CARTON PACK LIST

The following sub-assemblies are supplied in carton packs under the C.P. part number stated. The contents of these carton packs are preserved and will not deteriorate under adverse conditions.

Part No.	Contents
Brake Lining	
C.P.38/A.M.2 2	NW243 Brake lining
16	W129 Rivet
C.P.184 2	W1414 Brake lining
16	W129 Rivet
Pistons	
C.P.199 1	E4899 Piston C.R. 7.5 : 1
2	E3049 Compression ring
1	E2898 Oil control ring
1	WE203E Gudgeon pin
2	WE479 Circlip
C.P.199 is also available in 0.010 in., 0.020 in. and 0.040 in. oversizes.	
C.P.200 1	E5329 Piston C.R. 8.5 : 1
2	E3049 Compression ring
1	E2898 Oil control ring
1	WE203E Gudgeon pin
2	WE479 Circlip
C.P. 200 is also available in 0.010 in., 0.020 in. and 0.040 in. overseas.	
C.P.201 1	E5317 Piston C.R. 11 : 1 (Alcohol fuel)
2	E3049 Compression ring
1	E2898 Oil control ring
1	WE203E Gudgeon pin
2	WE479 Circlip
Piston Rings	
C.P. 99 4	E3049 Compression ring
2	E2898 Oil control ring
C.P. 99 is also available in 0.010 in., 0.020 in. and 0.040 in. oversizes.	
Valve springs	
C.P.188 4	E4221 Inner spring (Red spot)
(6T) 4	E4222 Outer spring (Red spot)
C.P.102 4	E3001 Inner spring (White spot)
(TR6, T120) 4	E3002 Outer spring (White spot)

CARTON PACK LIST — continued

Part No.	Contents
Valves	
C.P.173 2 E3310 Inlet valve	
(6T, TR6) 2 E3927 Exhaust valve	
Valve Guides	
C.P.97 2 E2899 Inlet guide	
(6T, TR6) 2 E2900 Exhaust guide	
De-coke Gasket Set All models D/GS1	

HOW TO USE THIS PARTS CATALOGUE

First check that the engine number of your machine is subsequent to that quoted on the title page.

Next consult the index on Page 5 for the parts or group of parts which you wish to locate. When you have located the parts make sure from the end columns that the part you have located does apply to your machine.

List the quantities required as single units; do not ask for "2 pairs" or "3 dozen".

In case of painted items always state the colour required. Painted parts are available only in the colours or alternatives specified for that model of that particular year.

<i>Colour</i>	<i>Suffix Letter to Part No.</i>
BLACK	W
SILVER	V
ALASKAN WHITE/GOLD... ..	AW/G
HI-FI SCARLET	HF

N.B. Hi-Fi Scarlet is a flamboyant finish applied over Gold Sheen.

Paint is available also in all colours in $\frac{1}{4}$ pint or 1 gallon tins.

PLEASE NOTE

THROUGHOUT THIS LIST, ASSEMBLIES ARE PRINTED IN CAPITALS AND THE COMPONENTS INCLUDED IN THAT ASSEMBLY ARE INDENTED IN THE DESCRIPTION COLUMN, REVERTING TO THE ORIGINAL ALIGNMENT WHEN THE ASSEMBLY IS COMPLETE. TO ORDER THE COMPLETE ASSEMBLY IT IS NECESSARY ONLY TO QUOTE THE ASSEMBLY NUMBER. ANY COMPONENT PARTS LISTED MAY ALSO BE OBTAINED SEPARATELY IF REQUIRED.

SPECIAL WORKSHOP TOOLS

A COMPLETE LIST OF WORKSHOP TOOLS CAN BE MADE AVAILABLE BY EITHER CONTACTING YOUR DEALER OR APPLYING DIRECT TO THE TRIUMPH SERVICE DEPARTMENT. IN MOST CASES THESE TOOLS ARE VERY COSTLY AS THEY ARE MADE ENTIRELY FOR WORKSHOP USE, AND THEREFORE, IT IS NOT RECOMMENDED THAT THE PRIVATE OWNER PURCHASES THE TOOLS IN ORDER TO AID SERVICING THE MACHINE ONCE OR TWICE ONLY. IN THESE CIRCUMSTANCES IT IS FAR MORE ECONOMICAL TO GET IN TOUCH WITH A RECOGNISED DEALER.

TRIUMPH SPARES

HOW TO ORDER. Every part is indicated by a number, and this should be quoted together with the description. In order to assist customers, dimensions have been given in many cases where parts are similar. Parts where possible have been listed in order of assembly and a number of the illustrations show the assembly order also. With these aids, there should be no difficulty in identifying the parts you require.

ALWAYS HEAD YOUR ORDER WITH THE ENGINE NUMBER, STAMPED ON THE LEFT SIDE OF THE ENGINE JUST BELOW THE CYLINDER, TOGETHER WITH THE PREFIX LETTERS.

WHERE TO OBTAIN. Triumph Spare Parts can only be obtained from an authorised Triumph Dealer, and we recommend our customers to place their orders with the Triumph Dealer in their district. When parts not usually asked for are required, and for which the Dealer may have to write or obtain specially, the postage or carriage incurred becomes payable.

TRIUMPH SPARES ARE NOT SUPPLIED TO PRIVATE OWNERS DIRECT FROM THE FACTORY. A LIST OF AUTHORISED DEALERS WHO STOCK TRIUMPH SPARES IS AVAILABLE ON REQUEST. IF DIFFICULTY IS EXPERIENCED IN OBTAINING THE REQUIRED PARTS, THE MATTER SHOULD BE TAKEN UP DIRECTLY WITH THE TRIUMPH SPARES DEPARTMENT.

Customers are warned against the risk incurred by purchasing parts that are not of genuine Triumph manufacture. This risk is eliminated if parts are ordered as instructed from recognised Dealers.

PATTERNS AND PARTS FOR REPAIR. It is not necessary to send patterns if the part number is quoted. The sending of patterns often delays the order as parcel post or rail takes longer than letter post.

Parts sent to Coventry for repair, replacement, or as patterns should bear the sender's Name and Address and clear instructions should accompany the parts. In your own interest send a copy of the advice note under separate cover. All parts must be forwarded carriage paid and care should be taken to ensure that all remittances are sent separately and not enclosed with the parts. Fragile units such as cylinders, etc., should always be boxed to avoid damage in transit. Complete machines should have all fitments such as windscreens, driving mirrors, tools, etc., removed by the sender before despatch, as it is impossible for us to accept responsibility in the event of loss in transit. We are always pleased to give estimates for overhauling and repairs, but should an estimate not be accepted, a charge will be made covering cost of dismantling and re-assembling, if carried out.

Communications relating to Parts should be addressed to the SPARES DEPARTMENT and for repairs, guarantee claims and technical advice to the SERVICE DEPARTMENT, Triumph Engineering Co. Ltd., Meriden Works, Allesley, Coventry. In order to facilitate quick reference, the quoting of any number, invoice number or reference from previous communications is essential. Accessories not of our manufacture should be sent direct to the actual makers, whose Name and Addresses appear below.

PROPRIETARY GROUP

Ancillary equipment which is fitted to our motor cycles is of the highest quality and is guaranteed by the manufacturers and not by ourselves. Any repairs or claims should be directed to the actual makers or their local agents who will always give owners every possible assistance. The following are the addresses of the various manufacturers:—

CARBURETTERS.

Messrs. Amal Ltd.,
Holdford Road,
Witton,
Birmingham, 6.

CHAINS.

Renold Chains Ltd.,
Wythenshawe,
Manchester.

ELECTRICAL EQUIPMENT.

Messrs. J. Lucas Ltd.,
Gt. Hampton Street,
Birmingham, 18.

TYRES.

Dunlop Rubber Co. Ltd.,
Fort Dunlop,
Birmingham, 24.

The Avon India Rubber Co. Ltd.,
Melksham,
Wilts.

SPARKING PLUGS.

Champion Sparking Plug Co. Ltd.,
Feltham,
Middlesex.

SPEEDOMETERS.

Messrs. Smiths Motor Accessories Ltd.,
Cricklewood Works,
London, N.W.2.

SUSPENSION UNITS.

Messrs. Girling Ltd.,
Kings Road,
Tyseley,
Birmingham, 11.

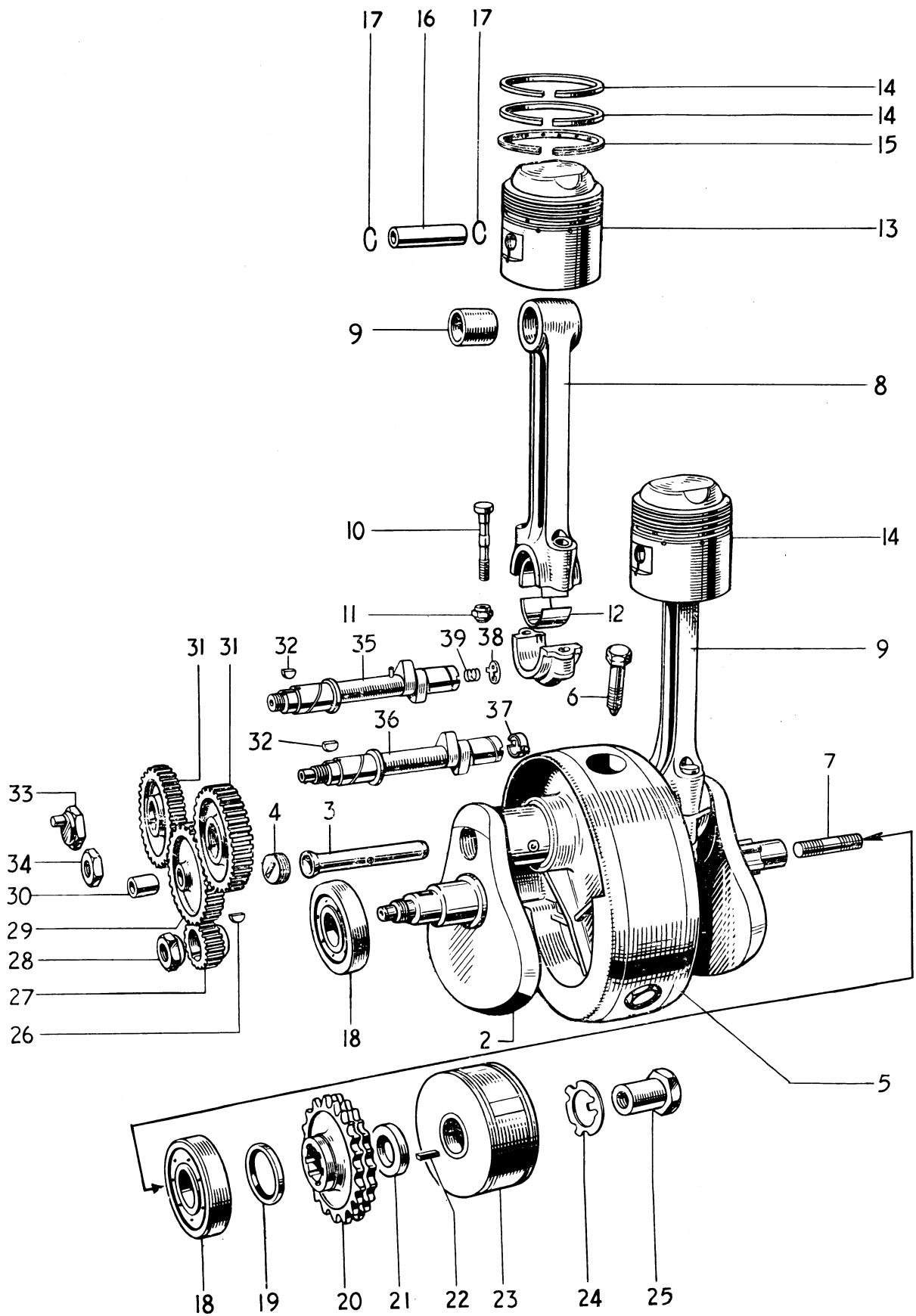

Fig. 1. CRANKSHAFT AND CONNECTING RODS

Ref. No.	Part No.	DESCRIPTION	6T	TR6	T120
CRANKSHAFT AND CONNECTING RODS					
1	E4642 71-2600	CRANKSHAFT AND FLYWHEEL ASSEMBLY ...	1	1	1
2	E4643	CRANKSHAFT C/W. OIL TUBE ...	1	1	1
3	E3903	Oil tube ...	1	1	1
4	E3905	Screwed plug ...	1	1	1
5	E4479 71-2425	Flywheel ...	1	1	1
6	*E3907	Flywheel bolt ...	3	3	3
7	E3114	Crankshaft stud (1 $\frac{3}{8}$ " O.A.) ...	1	1	1
8	E3606 70-9525	CONNECTING ROD ...	2	-	-
8	E3606 D	CONNECTING ROD ...	-	2	2
9	E1511	Small end bush ...	2	2	2
10	E2490A 70-2490/001	Connecting rod bolt ...	4	4	4
11	E2922	Self locking nut ...	4	4	4
12	E3586	Big end bearing ...	4	4	4
13	CP199	PISTON COMPLETE 7.5:1 C.R. ...	2	-	-
13	CP200 70-9488	PISTON COMPLETE 8.5:1 C.R. ...	-	2	2
14	E3049 70-6864	Taper compression ring ...	4	4	4
15	E2898 70-6865	Oil control ring ...	2	2	2
16	WE203E 70-6863	Gudgeon pin ...	2	2	2
17	WE479 70-6869	Circlip ...	4	4	4
18	E1591	Main bearing ...	2	2	2
19	E3876	Oil seal ...	1	1	1
20	E5446 70-5450	Engine sprocket, 29 teeth Duplex ...	1	1	1
21	E4573	Distance piece ...	1	1	1
22	E3974	Rotor key ...	1	1	1
23	5421390154202275	Rotor, type RM19 ...	1	1	1
24	E3975	Tab washer ...	1	1	1
25	E3977	Nut ...	1	1	1
26	E1580	Key ...	1	1	1
27	E5447	Timing pinion ...	1	1	1
28	E4565	Nut ...	1	1	1
29	E4566 70-6159	INTERMEDIATE WHEEL ...	1	1	1
30	E400	Intermediate wheel bush... ...	1	1	1
31	E4562	Camshaft wheel... ...	2	2	2
32	E1558	Camshaft key ...	2	2	2
33	E1463	Inlet camshaft nut ...	1	1	1
34	E4563	Exhaust camshaft nut ...	1	1	1
35	E4818	Inlet camshaft ...	1	-	-
35	E4819 71-0040	Inlet camshaft ...	-	1	1
36	E4848	Exhaust camshaft ...	1	-	-
36	E4855	EXHAUST CAMSHAFT ...	-	1	1
37	E4700	Tachometer drive thimble ...	-	1	1
38	E5316	Rotary breather valve ...	1	1	1
39	E2256	Breather valve spring ...	1	1	1

* Use D524 Loctite Sealant

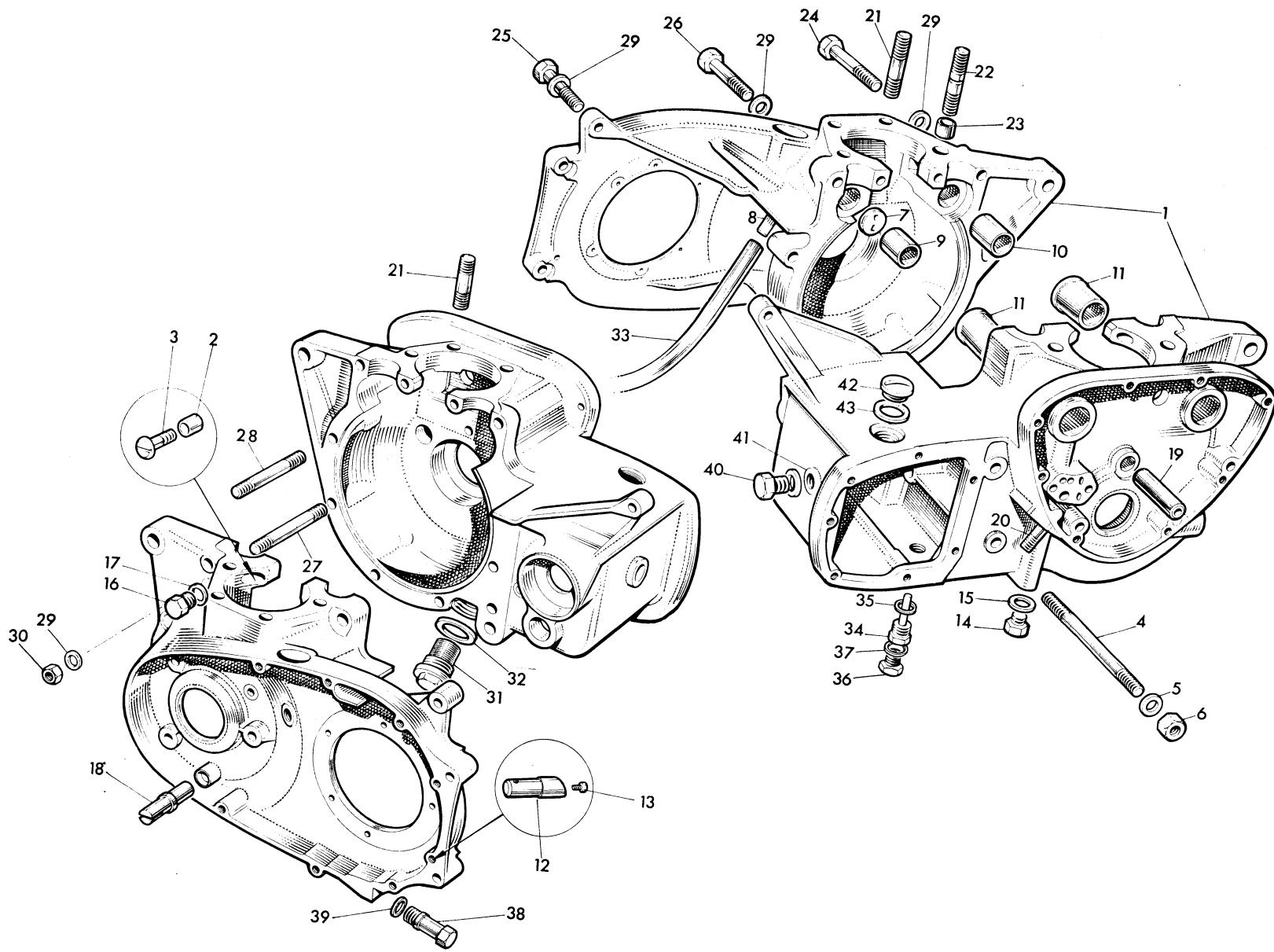

Fig. 2. CRANKCASE

Ref. No.	Part No.	DESCRIPTION	QUANTITY
CRANKCASE			
1	E4533/4 70-9752 70-9753	CRANKCASE	6T 1 TR6 1 T120 1
2	E3716	Hollow Dowel	1 1 1
3	E5232	Screw ($\frac{21}{32}$ in. U.H.)	2 2 2
4	E4542	Stud ($4\frac{1}{2}$ in. O.A.)	2 2 2
5	S25-2 60-4246	Plain washer	2 2 2
6	P0172A 99-0407	Nut	2 2 2
7	GS87 99-3525	Breather disc	1 1 1
8	E2724	Breather pipe	1 1 1
9	E2260 71-0288	Inlet camshaft bush	1 1 1
10	E1516 71-0287	Exhaust camshaft bush	1 1 1
11	E1479 71-0286	Camshaft bush	2 2 2
12	E4744	Chain oiler tube	1 1 1
13	E3885	Chain oiler jet	1 1 1
13	H689	Blanking screw	A A A
14	E4539	Oilway plug	1 1 1
15	GS439	Fibre washer	1 1 1
16	E4706	Tachometer drive plug	1 1 1
17	T1257	Fibre washer	1 1 1
18	E4147	Chain tensioner abutment	1 1 1
19	E375	Intermediate wheel spindle	1 1 1
20	E3717	Oil pipe stud ($1\frac{1}{2}$ in. O.A.)	1 1 1
21	E672	Cylinder stud ($1\frac{5}{8}$ in. O.A.)	6 6 6
22	E3523 70-3924	Cylinder stud ($1\frac{5}{8}$ in. O.A.)	2 2 2
23	E1534A 70-8751	Hollow dowel	2 2 2
24	E4541	Bolt ($2\frac{1}{2}$ in. U.H.)	1 1 1
25	E4540	Bolt ($1\frac{3}{4}$ in. U.H.)	1 1 1
26	E4098	Bolt ($1\frac{7}{8}$ in. U.H.)	1 1 1
27	E4856	Stud ($5\frac{1}{8}$ in. O.A.)	1 1 1
28	E2888	Stud ($3\frac{7}{8}$ in. O.A.)	3 3 3
29	S25-3 60-4247	Plain washer	11 11 11
30	S1-51 21-1875	Nut	8 8 8
31	E5312	Crankcase filter... ..	1 1 1
32	E5315 70-8782	Copper washer	1 1 1
33	E5375	Breather extension pipe	1 1 1
34	T1112	Drain plug (with level tube)	1 1 1
35	T1257	Fibre washer	1 1 1
36	T361	Level plug	1 1 1
37	WE170 60-4263	Fibre washer	1 1 1
38	E4922 70-6347	Drain and adjuster plug	1 1 1
39	T1738	Fibre washer	1 1 1
40	E4579	Blanking plug	1 1 1
41	T1921	Fibre washer	1 1 1
42	E732 57-2166	Filler plug	2 2 2
43	NE507 70-8782	Fibre washer	2 2 2

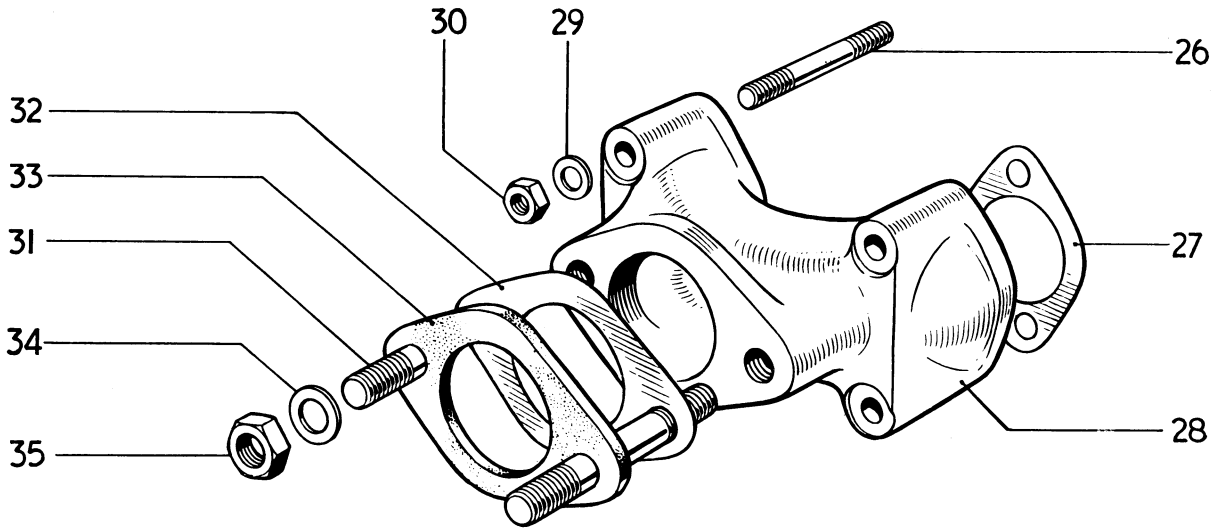
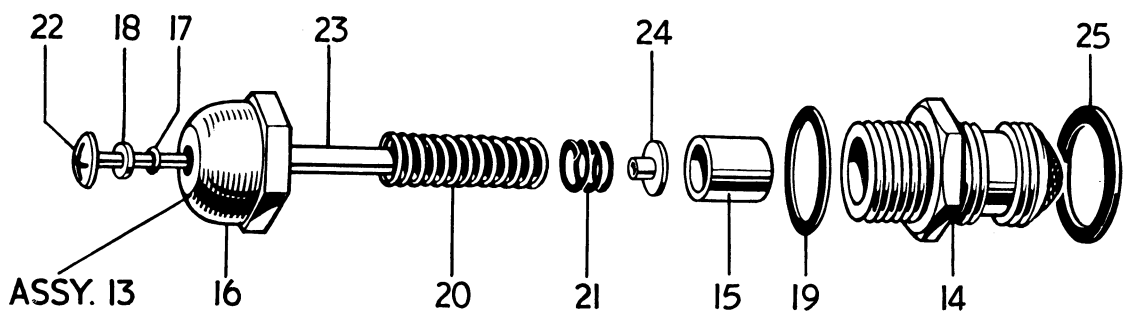
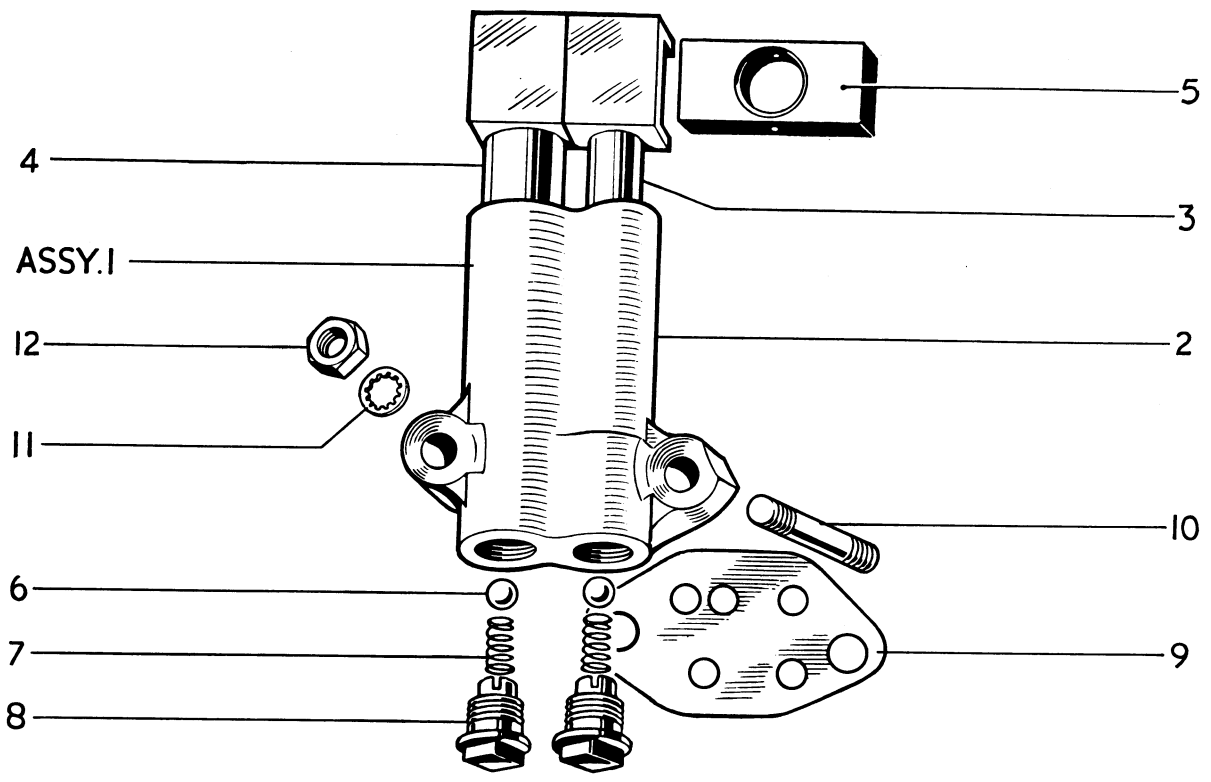

Fig. 3. OIL PUMP AND RELEASE VALVE AND MANIFOLD

Ref. No.	Part No.	DESCRIPTION	QUANTITY
OIL PUMP AND RELEASE VALVE AND MANIFOLD			
			6T TR6 T120
1	E3878 70-6928	OIL PUMP	1 1 1
2	E3731	Pump body... ..	1 1 1
3	GS153	Feed plunger	1 1 1
4	E1476	Scavenge plunger	1 1 1
5	E495	Drive block	1 1 1
6	S70-7 70-2363	Valve ball	2 2 2
7	E403	Valve spring	2 2 2
8	E2360	Screwed plug	2 2 2
9	E3730 71-1461	Joint washer	1 1 1
10	E3718	Oil pump stud (1 $\frac{5}{16}$ in. U.H.)	2 2 2
11	E3887	Serrated washer	2 2 2
12	E3732	Nut	2 2 2
13	E4191 70-5896	OIL RELEASE VALVE AND INDICATOR	1 1 1
14	E2794	Valve body	1 1 1
15	GS251 70-8752	Piston	1 1 1
16	E4192	Cap	1 1 1
17	E4193	Sealing ring	1 1 1
18	E4194	Cup	1 1 1
19	GS254 70-8754	Fibre washer	1 1 1
20	E2788	Main spring	1 1 1
21	E2789	Auxiliary spring	1 1 1
22	E2791	Button and shaft	1 1 1
23	E2793	Sealing rubber	1 1 1
24	E2792	Shaft nut	1 1 1
25	E1670 60-3355	Fibre washer	1 1 1
26	E2973	Stud (1 $\frac{5}{16}$ in. O.A.)	4 4 -
27	E3334	Joint washer	2 2 -
28	E3304	Inlet manifold	1 1 -
29	S25-1360-4248	Plain washer	4 4 -
30	W103	Nut	4 4 -
31	E2962	Stud (1 $\frac{7}{32}$ in. O.A.)	2 2 -
32	NA43A 71-1416	Joint washer	1 1 -
33	E2968 70-4918	Insulating block	1 1 -
34	S25-360-4247	Plain washer	2 2 -
35	S1-5121-0001/051	Nut	2 2 -

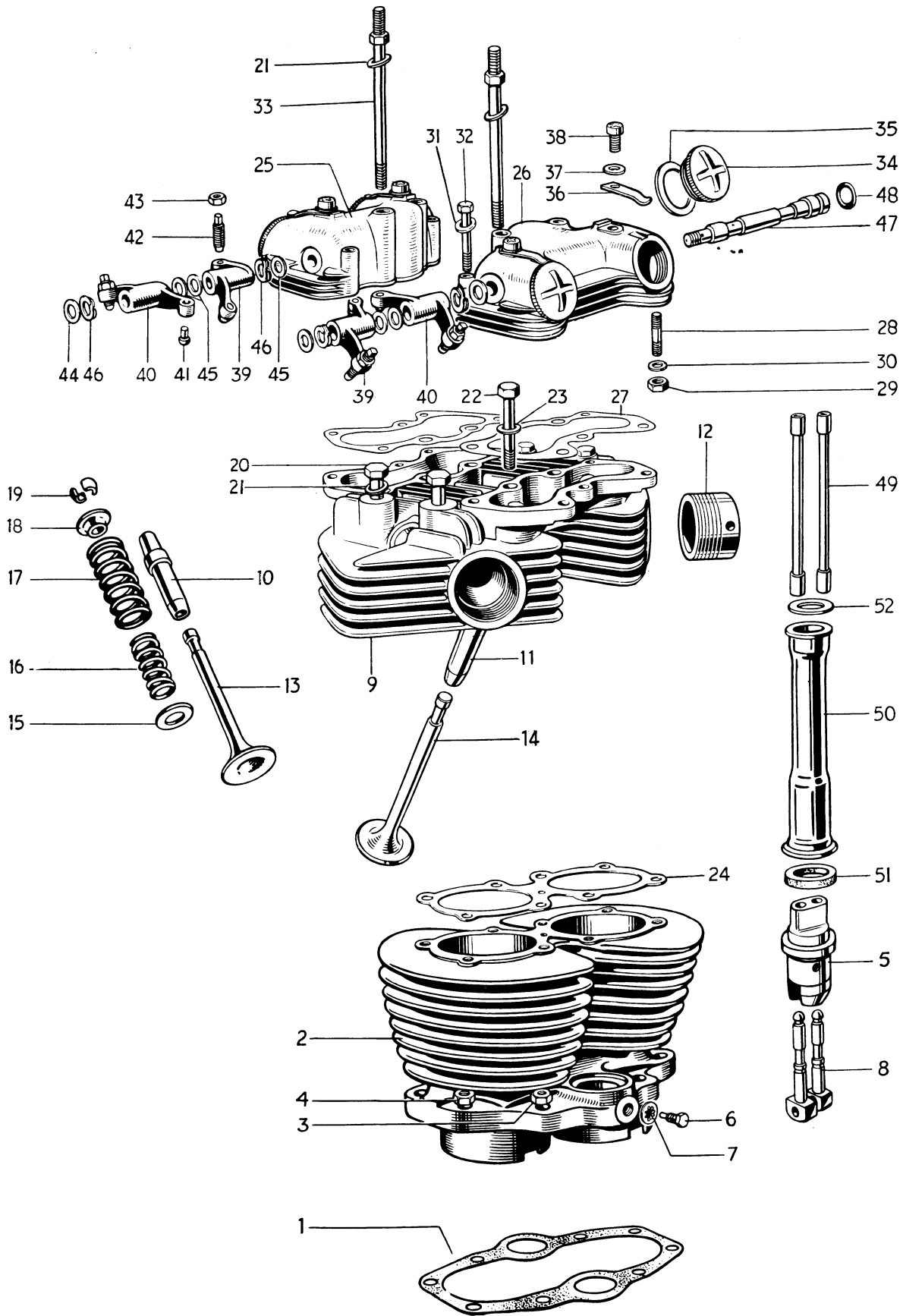

Fig. 4. CYLINDER BLOCK AND HEAD, 6T AND TR6

Ref. No.	Part No.	DESCRIPTION	QUANTITY	6T	TR6
CYLINDER BLOCK AND HEAD, 6T AND TR6					
1	E289470-6309	Cylinder base washer	1	1	1
2	E454670-6304	Cylinder block	1	1	1
3	W76	Inner cylinder base nut	4	4	4
4	P0172A 99-0047	Outer cylinder base nut	4	4	4
5	E1477	Tappet guide block	2	2	2
6	H200	Tappet block screw	2	2	2
7	E1612	Serrated washer	2	2	2
8	E3059 71-7008	Tappet	4	4	4
9	E4552	CYLINDER HEAD c/w GUIDES	1	1	1
10	E2899 71-3292	Inlet valve guide	2	2	2
11	E2900 71-3293	Exhaust valve guide	2	2	2
12	E3583	Exhaust pipe adaptor	2	2	2
13	E3310	Inlet valve	2	2	2
14	E3927	Exhaust valve	2	2	2
15	E5008	Bottom cup	4	-	4
15	E1544	Bottom cup	-	4	4
16	E4221	Inner valve spring (red spot)	4	-	4
17	E4222 70-7400	Outer valve spring (red spot)	4	-	4
16	E3001	Inner valve spring (white spot)	-	4	4
17	E3002	Outer valve spring (white spot)	-	4	4
18	E1543	Top collar	4	4	4
19	WE259A 71-3748	Split cotter	8	8	8
20	E327	Cylinder head bolt (3 $\frac{3}{8}$ in. U.H.)	4	4	4
21	F2184	Plain washer	8	8	8
22	E4771	Bolt (3 in. U.H.)	1	1	1
23	S25-3 60-4247	Plain washer	1	1	1
24	E4547	Cylinder head gasket	1	1	1
25	E4550	Inlet rocker box	1	1	1
26	E4551	Exhaust rocker box	1	1	1
27	E4549 70-9348	Joint washer	2	2	2
28	E2980	Rocker box stud (1 $\frac{5}{8}$ in. O.A.)	6	6	6
29	F879	Rocker box nut... ..	6	6	6
30	E3302	Plain washer	6	6	6
31	E2982	Rocker box bolt (2 $\frac{5}{32}$ in. U.H.)	4	4	4
32	S25-13 60-4248	Plain washer	4	4	4
33	E1596	Cylinder head bolt (for torque stay)	4	4	4
34	E4610 71-2744	Inspection cap	4	4	4
35	E3751	Joint washer	4	4	4
36	E4609	Locking spring	4	4	4
37	WE170 60-4263	Fibre washer	4	4	4
38	T1553	Screw ($\frac{3}{8}$ in. U.H.)	4	4	4
39	E1457	ROCKER (right exhaust, left inlet)	2	2	2
40	E1458	ROCKER (left exhaust, right inlet)	2	2	2
41	E1483	Rocker ball pin	4	4	4
42	E1513	Rocker adjusting pin	4	4	4
43	E470	Adjuster lock nut	4	4	4
44	E1330	Thrust washer, $\frac{3}{8}$ in.	2	2	2
45	E1575	Thrust washer, $\frac{1}{2}$ in.	6	6	6
46	E1574	Spring washer	4	4	4
47	E1512	Spring washer	2	2	2
48	E3253 60-3548	Sealing rubber	2	2	2
49	E2620	Push rod	4	4	4
50	E3646	Push rod	2	2	2
51	E1496	Cover tube	2	2	2
51	E1496	Bottom joint washer	2	2	2
52	E3547	Top joint washer	2	2	2

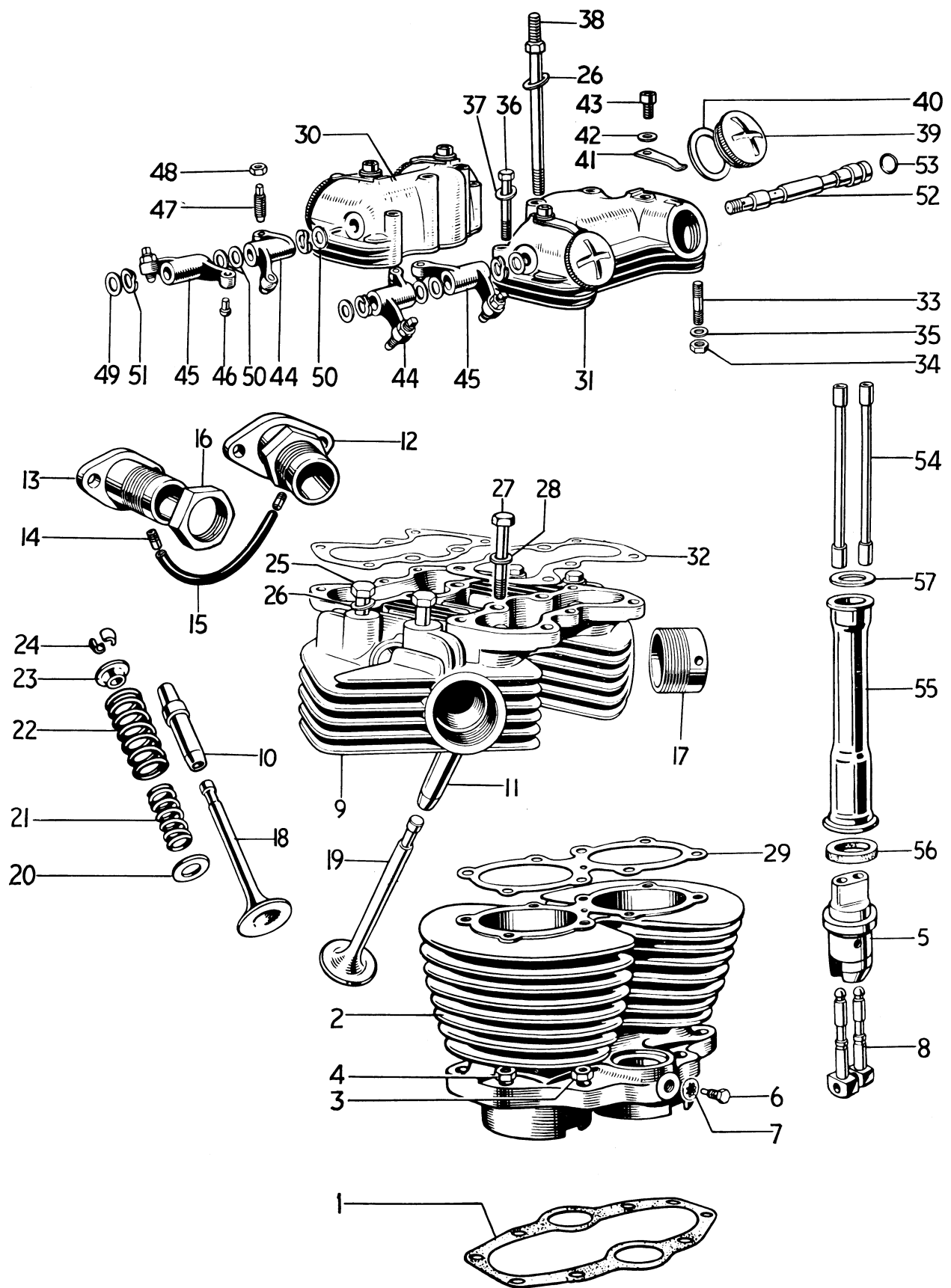

Fig. 5. CYLINDER BLOCK AND HEAD, T120

Ref. No.	Part No.	DESCRIPTION	QUANTITY
CYLINDER BLOCK AND HEAD, T120			T120
1	E2894 70-6309	Cylinder base washer	1
2	E4546 70-6304	Cylinder block	1
3	W76	Inner cylinder base nut	4
4	P0172A	Outer cylinder base nut	4
5	E1477	Tappet guide block	2
6	H200	Tappet block screw	2
7	E1612	Serrated washer	2
8	E3059	Tappet	4
9	E5348 70-5727	CYLINDER HEAD c/w GUIDES	1
10	E3827 71-3294	Inlet valve guide	2
11	E3828 71-3295	Exhaust valve guide	2
12	E5349 70-5351	Carburetter adaptor, left	1
13	E5350 70-5352	Carburetter adaptor, right	1
14	E4791	Connector	2
15	E4792	Balance pipe	1
16	E4608	Adaptor locking nut	2
17	E3583	Exhaust pipe adaptor	2
18	E4603	Inlet valve	2
19	E2904	Exhaust valve	2
10	E1544	Bottom cup	4
21	E3001	Inner valve spring	4
22	E3002	Outer valve spring	4
23	E1543	Top collar	4
24	WE259A 71-3748	Split cotter	8
25	E327	Cylinder head bolt (3 $\frac{3}{8}$ in. U.H.)	4
26	F2184	Plain washer	8
27	E4771	Bolt (3 in. U.H.)	1
28	S25-3 60-4247	Plain washer	1
29	E4547	Cylinder head gasket	1
30	E4550	Inlet rocker box	1
31	E4551	Exhaust rocker box	1
32	E4549 70-9348	Joint washer	2
33	E2980	Rocker box stud ($\frac{1}{8}$ in. O.A.)	6
34	F879	Nut	6
35	E3302	Plain washer	6
36	E2982	Rocker box bolt (2 $\frac{5}{32}$ in. U.H.)	4
37	S25-13 60-4248	Plain washer	4
38	E1596	Cylinder head bolt (for torque stay)	4
39	E4610 71-2744	Inspection cap	4
40	E3751	Joint washer	4
41	E4609	Locking spring	4
42	WE170 60-4263	Fibre washer	4
43	T1553	Screw ($\frac{3}{8}$ in. U.H.)	4
44	E1457	ROCKER (right exhaust, left inlet)	2
45	E1458	ROCKER (left exhaust, right inlet)	2
46	E1483	Rocker ball pin	4
47	E1513	Rocker adjusting pin	4
48	E470	Adjuster lock nut	4
49	E1330	Thrust washer, $\frac{3}{8}$ in.	2
50	E1575	Thrust washer, $\frac{1}{2}$ in.	6
51	E1574	Spring washer	4
52	E1512	Rocker spindle	2
53	E3253 60-3548	Sealing rubber	4
54	E2620	Push rod	2
55	E3646	Cover tube	2
56	E1496	Bottom joint washer	2
57	E3547	Top joint washer	2

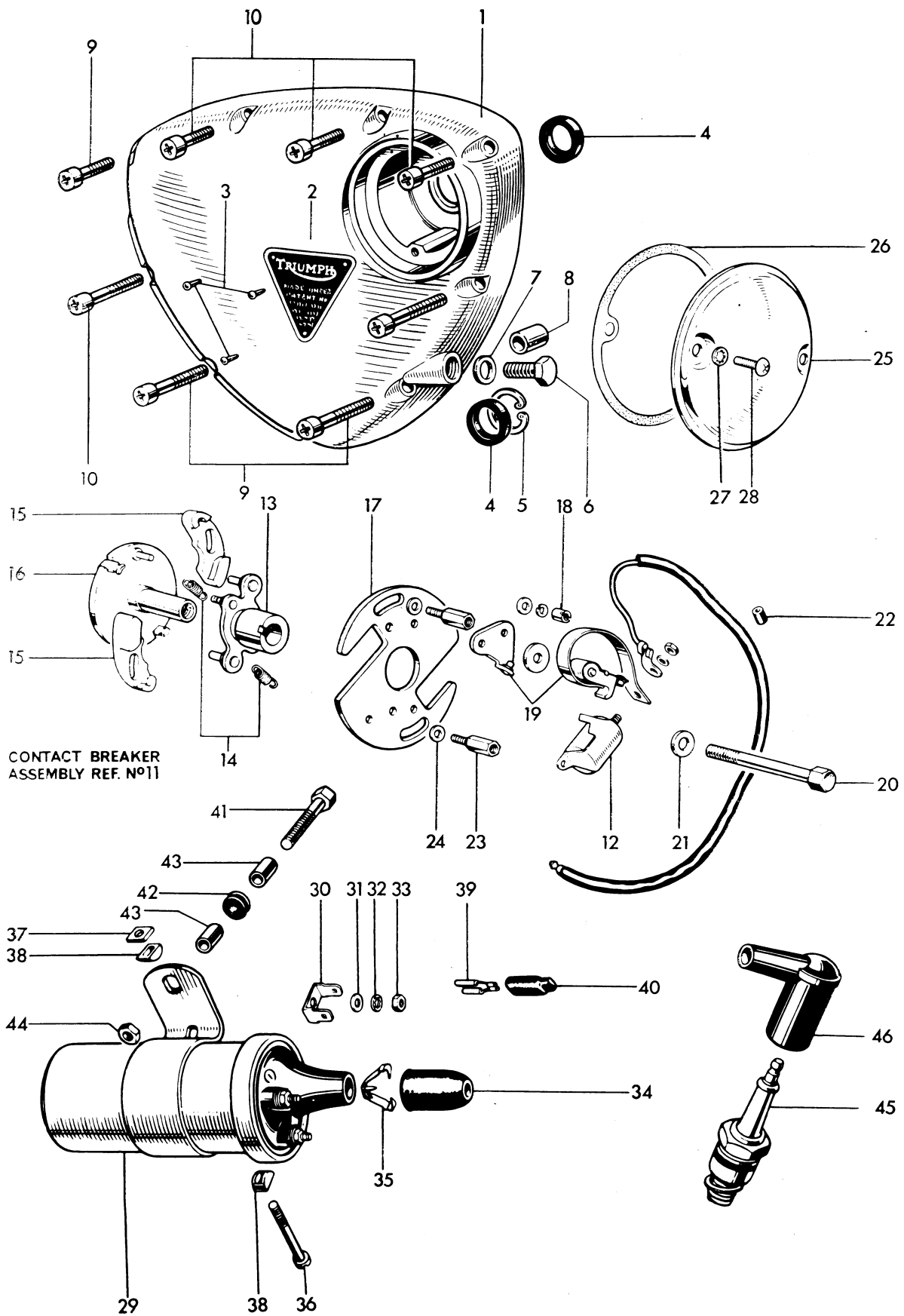

Fig. 6. TIMING COVER, CONTACT BREAKER AND COILS

Ref. No.	Part No.	DESCRIPTION	QUANTITY
TIMING COVER, CONTACT BREAKER AND COILS			
			6T TR6 T120
1	E4567	Timing cover	1 1 1
2	E4016	Patent plate	1 1 1
3	D208-560-4255	Hammer-drive screw	3 3 3
4	E4568	Oil seal	2 2 2
5	E4569	Circlip	1 1 1
6	E2615	Timing cover plug	1 1 1
7	E1335	Copper washer	1 1 1
8	T989	Hollow dowel	2 2 2
9	E3668	Screw (1 $\frac{5}{16}$ in. U.H.)	3 3 3
10	E3204	Screw (1 in. U.H.)	5 5 5
11	47605 N.L.A.	CONTACT BREAKER, type 4CA	1 1 1
12	425377	Condenser	2 2 2
13	54441729	Cam... ..	1 1 1
14	54415642 <i>Disc</i>	Spring set	1 1 1
15	425379 N.L.A.	Weight	2 2 2
16	54415751 <i>54418787</i>	Sleeve and action plate	1 1 1
17	425370	Base plate	1 1 1
18	169194	Slotted nut... ..	4 4 4
19	54415803	Contact set	2 2 2
20	E5451	Bolt (2 in. U.H.)	1 1 1
21	S25-4370-8163	Plain washer	1 1 1
22	E4707	Rubber grommet	1 1 1
23	E4747	Pillar bolt	2 2 2
24	E2351	Plain washer	2 2 2
25	E457170-8737	Cover	1 1 1
26	E504971-1462	Joint washer	1 1 1
27	GS299 <i>60-4256</i>	Serrated washer	2 2 2
28	F4715	Screw ($\frac{13}{32}$ in. U.H.)	2 2 2
29	45110	IGNITION COIL, type MA12	2 - -
29	45152	IGNITION COIL, type MA6	- 2 2
30	54190108	Lucar terminal	4 4 4
31	131023	Plain washer (E2351)	4 4 4
32	188330	Serrated washer (GS299)	4 4 4
33	166043	Nut (F3799)	4 4 4
34	421554 <i>54953628</i>	Rubber grommet	2 2 2
35	421863	Cable clip	2 2 2
36	100104 <i>Disc</i>	Screw	2 2 2
37	169160	Square nut	2 2 2
38	422369 <i>Disc</i>	"D" washer	4 4 4
39	54942078 <i>54960661</i>	Lucar connector	4 4 4
40	54190042	Insulating cover... ..	4 4 4
41	F4744	Bolt (1 $\frac{5}{16}$ in. U.H.)	2 2 2
42	F5466	Rubber grommet	2 2 2
43	F4366	Distance piece	4 4 4
44	E3290	Self locking nut	2 2 2
45	—	Sparking plug (Champion N4)	2 2 2
46	D297	Plug cover and suppressor	2 2 2
46	D262	Plug cover	A A A

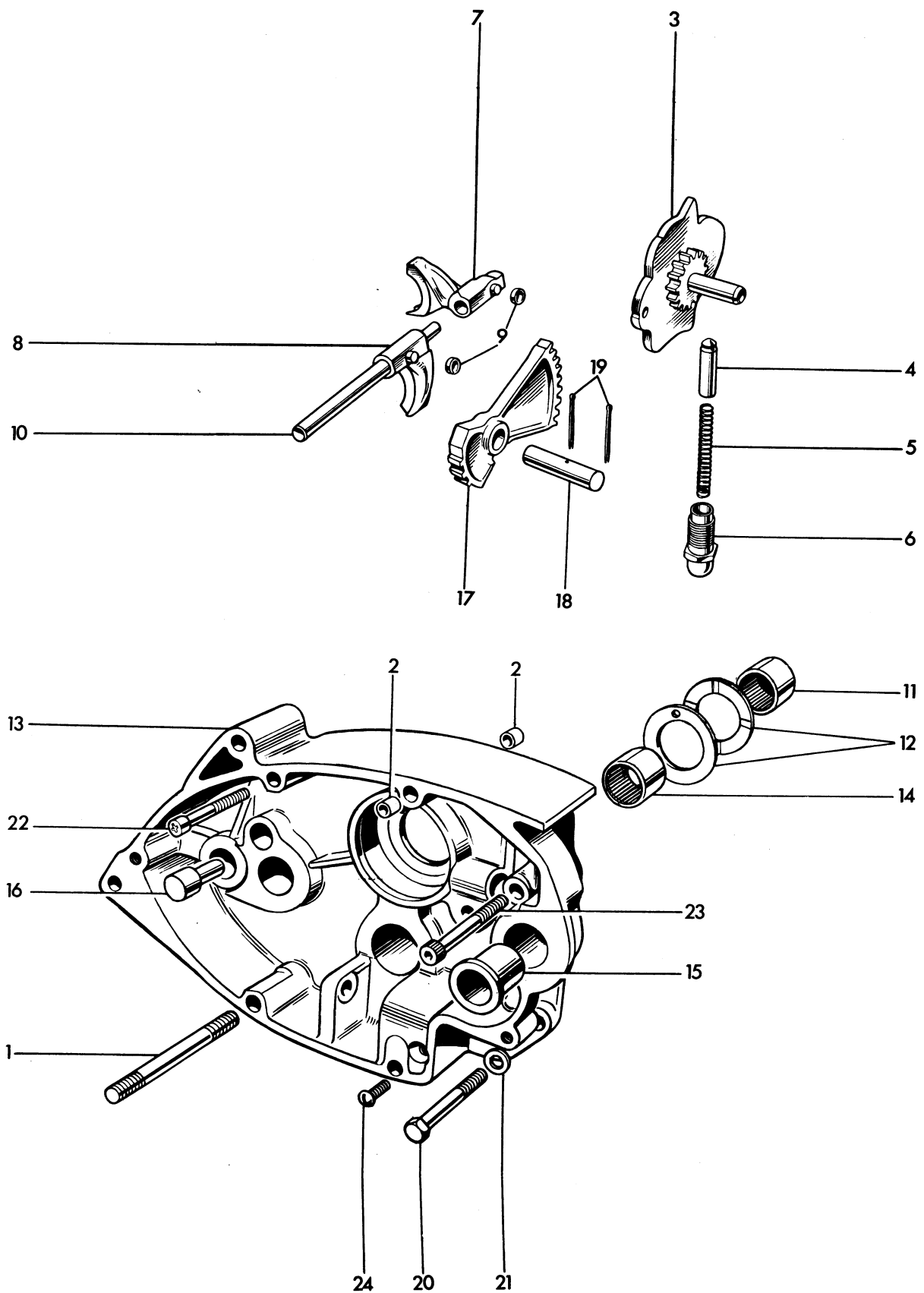

Fig. 7. GEARBOX INNER COVER AND SELECTORS

Ref. No.	Part No.	DESCRIPTION	6T	TR6	T120
GEARBOX INNER COVER AND SELECTORS					
1	E4535	Stud (3 in. O.A.)	2	2	2
2	T989	Hollow dowel	4	4	4
3	T500 57-4099	Gear selector camplate	1	1	1
4	T44 57-3660	Camplate index plunger	1	1	1
5	T373	Index plunger spring	1	1	1
6	T372	Index plunger holder	1	1	1
7	T260B 57-2596	Mainshaft selector fork	1	1	1
8	T913 57-4307	Layshaft selector fork	1	1	1
9	NT261 97-2595	Selector fork roller	2	2	2
10	T291	Selector fork rod	1	1	1
11	T1606	Layshaft bearing	1	1	1
12	T1607	Thrust washer	2	2	2
13	T1703	GEARBOX INNER COVER	1	1	1
14	T1614	Layshaft bearing	1	1	1
15	T412	Gearchange spindle bush... ..	1	1	1
16	T45	Kickstarter stop	1	1	1
17	T397	Camplate operating quadrant... ..	1	1	1
18	T1896	Quadrant spindle	1	1	1
19	$\frac{5}{64}$ in. x $1\frac{3}{8}$ in.	Split pin	2	2	2
20	T1778	Bolt ($1\frac{1}{8}$ in. U.H.)	1	1	1
21	E3446	Plain washer	1	1	1
22	E3204	Screw (1 in. U.H.)	1	1	1
23	T1779	Socket screw ($1\frac{3}{4}$ in. U.H.)	1	1	1
24	E3728	Countersunk screw ($\frac{15}{16}$ in. U.H.)	1	1	1

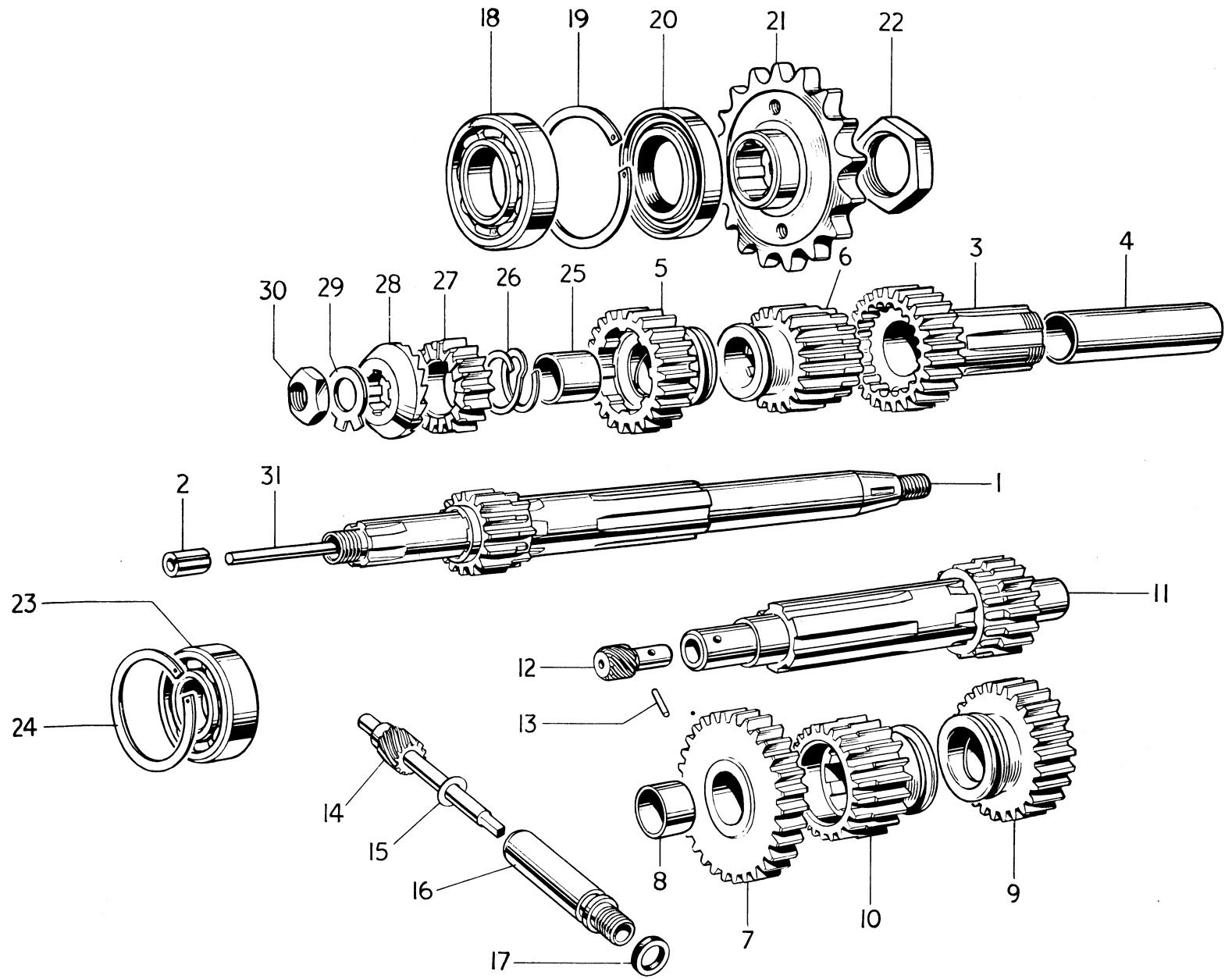

Fig. 8. GEARBOX SHAFTS AND GEARS

Ref. No.	Part No.	DESCRIPTION	QUANTITY		
GEARBOX SHAFTS AND GEARS					
1	T914 57-2436	MAINSHAFT c/w LOW GEAR (16T)	6T	TR6	T120
2	PT108B 57-3988	Clutch rod bush	1	1	1
3	T1914	MAINSHAFT HIGH GEAR (26T)	1	1	1
4	T1370	High gear bush	1	1	1
5	T917 57-3858	Mainshaft third gear (24T)	1	1	1
6	T916 57-3857	Mainshaft second gear (20T)	1	1	1
7	T926 57-3856	LAYSHAFT LOW GEAR (30T)	1	1	1
8	T928	Low gear bush	1	1	1
9	T1065 57-3861	Layshaft second gear (26T)	1	1	1
10	T930 57-3860	Layshaft third gear (22T)	1	1	1
11	T1843	Layshaft c/w high gear (20T)	1	1	1
12	T1744	Speedometer pinion, solo (10T)	1	1	1
12	T1747	Speedometer pinion, sidecar (9T)	A	A	A
13	T925	Securing pin	1	1	1
14	T1745	Speedometer gear, solo (15T)	1	1	1
14	T1748	Speedometer gear, sidecar (15T)	A	A	A
15	T825	Thrust washer	1	1	1
16	T933	Speedometer drive bush	1	1	1
17	T948	Rubber sealing ring	1	1	1
18	T448	High gear bearing	1	1	1
19	T489 70-0489	Circlip	1	1	1
20	T946	Oil seal	1	1	1
21	T1919 57-1919/020	Gearbox sprocket (20 teeth) solo	1	-	-
21	T1918 57-1918/019	Gearbox sprocket (19 teeth) solo	-	1	1
21	T1917 57-1917/018	Gearbox sprocket (18 teeth) side-car	A	-	-
21	T1916 57-1916/017	Gearbox sprocket (17 teeth) side-car	-	A	A
22	T440	Gearbox sprocket nut	1	1	1
23	S35-760-3552	Mainshaft bearing	1	1	1
24	T280	Circlip	1	1	1
25	T1338 57-1963	Pinion sleeve	1	1	1
26	T1250	Pinion spring	1	1	1
27	T730	Kickstarter pinion	1	1	1
28	T731	Kickstarter ratchet	1	1	1
29	T732	Tab washer	1	1	1
30	NT29799-3542	Nut	1	1	1
31	T1736	Clutch operating rod	1	1	1

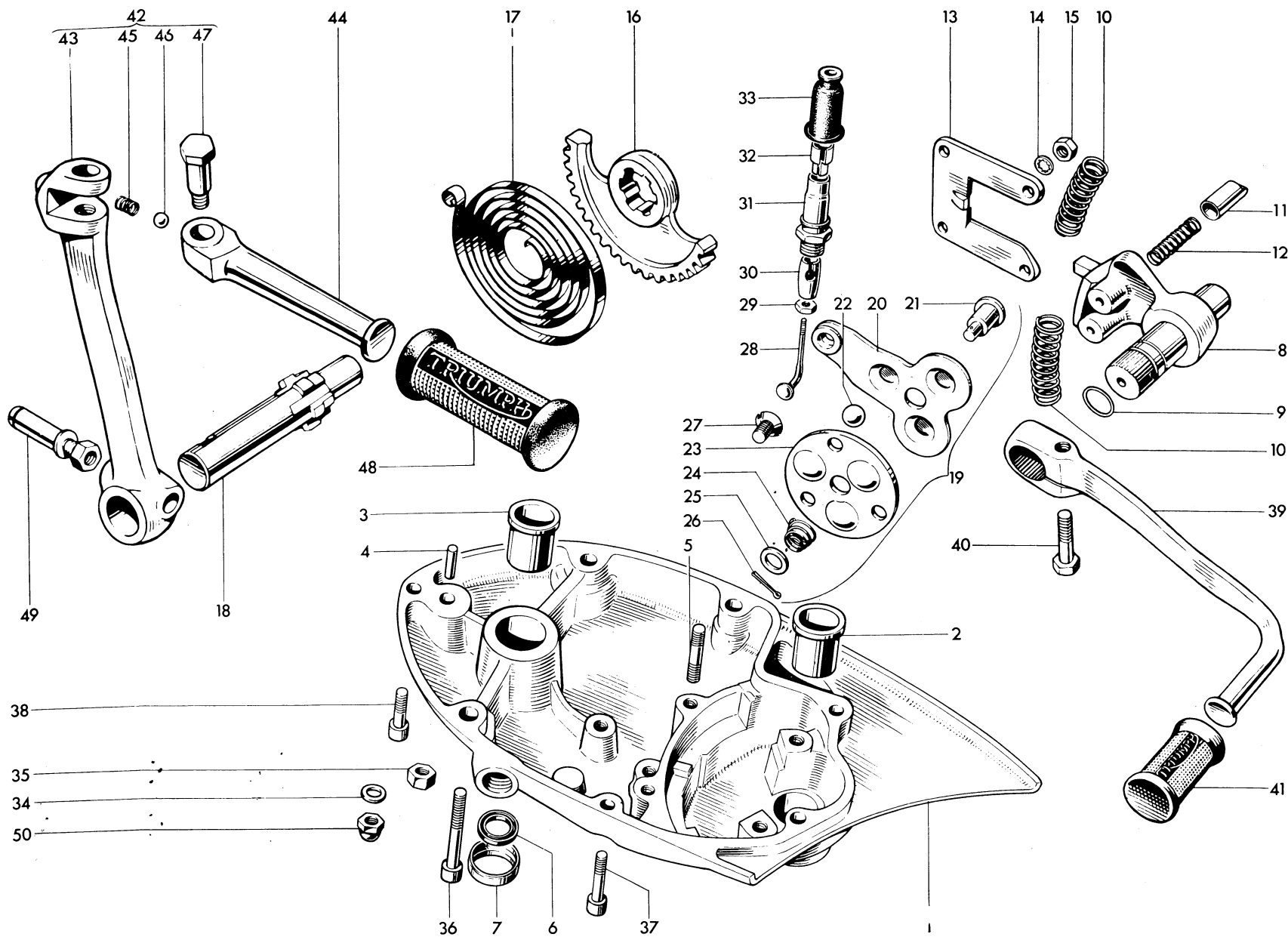

Fig. 9. GEARBOX OUTER COVER

Ref. No.	Part No.	DESCRIPTION	QUANTITY
GEARBOX OUTER COVER			
			6T TR6 T120
1	T1986	GEARBOX OUTER COVER	1 1 1
2	T57	Gearchange spindle bush... ..	1 1 1
3	T23	Kickstarter spindle bush	1 1 1
4	T47	Kickstarter spring anchor pin	1 1 1
5	T454	Guide plate stud ($\frac{7}{8}$ in. O.A.)	4 4 4
6	T1956	Oil seal	1 1 1
7	T1955	Oil seal housing	1 1 1
8	T408/957-0408/005	Gearchange quadrant	1 1 1
9	E3309/60-3530	Rubber "O" ring	1 1 1
10	T404	Quadrant return spring	2 2 2
11	T406	Gearchange quadrant plunger	2 2 2
12	T405	Plunger spring	2 2 2
13	T407	Guide plate	1 1 1
14	E1612	Serrated washer	4 4 4
15	F879	Nut	4 4 4
16	T25A 57-0025/001	Kickstarter quadrant 57-4117	1 1 1
17	T31	Kickstarter return spring	1 1 1
18	T24A 57-0024/001	Kickstarter axle 57-4756	1 1 1
19	T1707	CLUTCH LEVER ASSEMBLY	1 1 1
20	T1708	Clutch lever	1 1 1
21	T1710	Lever shaft	1 1 1
22	T1771 60-2368	Ball, $\frac{3}{8}$ in. diam.	3 3 3
23	T1711 57-4589	Thrust plate	1 1 1
24	T1712	Return spring	1 1 1
25	GS127 57-3673	Plain washer	1 1 1
26	$\frac{5}{64}$ in. x $\frac{1}{2}$ in. 60-2701	Split pin	1 1 1
27	T1713	Countersunk screw ($\frac{3}{8}$ in. O.A.)	2 2 2
28	T1714	Spoke	1 1 1
29	T1937	Locknut	1 1 1
30	T1946	Connector	1 1 1
31	T1644	Abutment	1 1 1
32	T1645	Adaptor	1 1 1
33	T1646	Rubber cover	1 1 1
34	S25-360-4247	Plain washer	2 2 2
35	S1-5121-0001/051	Nut	1 1 1
36	E3802	Screw ($2\frac{3}{4}$ in. U.H.)	2 2 2
37	E3668	Screw ($1\frac{5}{16}$ in. U.H.)	2 2 2
38	E3204	Screw (1 in. U.H.)	1 1 1
39	T1750 57-7010	Gearchange pedal	1 1 1
40	W932 14-0201	Bolt (1 in. U.H.)	1 1 1
41	T449 57-2450	Pedal rubber	1 1 1
42	T1938 57-3632	FOLDING KICKSTARTER 57-7018	1 1 1
43	T1939 57-2095	Kickstarter lever ... 57-2173	1 1 1
44	T1272 57-7017	Kickstarter pedal	1 1 1
45	T1167	Pedal locating spring	1 1 1
46	S70-3 60-2364	Steel ball, $\frac{1}{4}$ in. diam.	1 1 1
47	T1273	Pedal bolt	1 1 1
48	F1814 57-2330	Pedal rubber	1 1 1
49	T1222 57-4356	Cotter pin c/w nut and washer	1 1 1
50	H1531	Domed nut	1 1 1

CLUTCH ASSEMBLY No 1

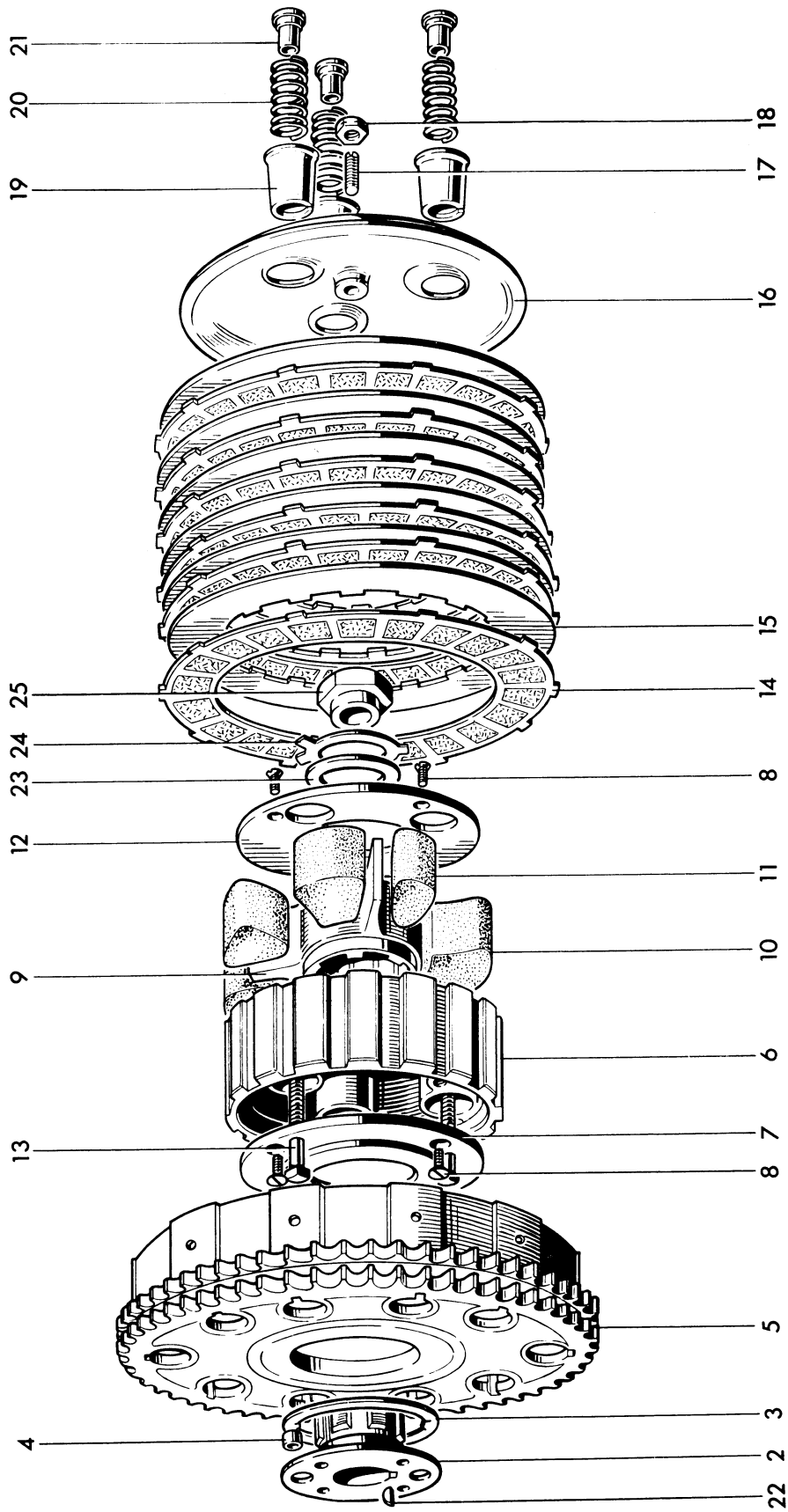

Fig. 10. CLUTCH

Ref. No.	Part No.	DESCRIPTION	6T	TR6	T120
CLUTCH					
1	T1928	CLUTCH COMPLETE	1	1	1
2	T1734	Hub	1	1	1
3	T1735	Thrust washer	1	1	1
4	T394	Roller	20	20	20
5	T1570	Sprocket and housing (58 teeth Duplex)	1	1	1
6	T1719	Centre	1	1	1
7	T1720	Inner plate	1	1	1
8	T1040	Countersunk screw (0.417 in. U.H.)	6	6	6
9	T1721	Shock absorber spider	1	1	1
10	T1722	Drive rubber (large)	3	3	3
11	T1723	Rebound rubber (small)	3	3	3
12	T1724	Outer plate	1	1	1
13	T423A 57-4754	Screwed pin (1 $\frac{3}{32}$ in. U.H.)	3	3	3
14	T1362 57-4763	Driving plate (bonded)	6	6	6
15	T1363	Driven plate	6	6	6
16	T1929 57-2156	Pressure plate	1	1	1
17	T1256 57-2729	Adjuster pin	1	1	1
18	GS662 60-4264	Nut	1	1	1
19	T1931	Spring cup	3	3	3
20	T1830	Spring	3	3	3
21	T427	Brass nut	3	3	3
22	S66-1 60-4253	Key	1	1	1
23	T1045	Cupped washer	1	1	1
24	T1046	Tab washer	1	1	1
25	T1047	Clutch securing nut	1	1	1

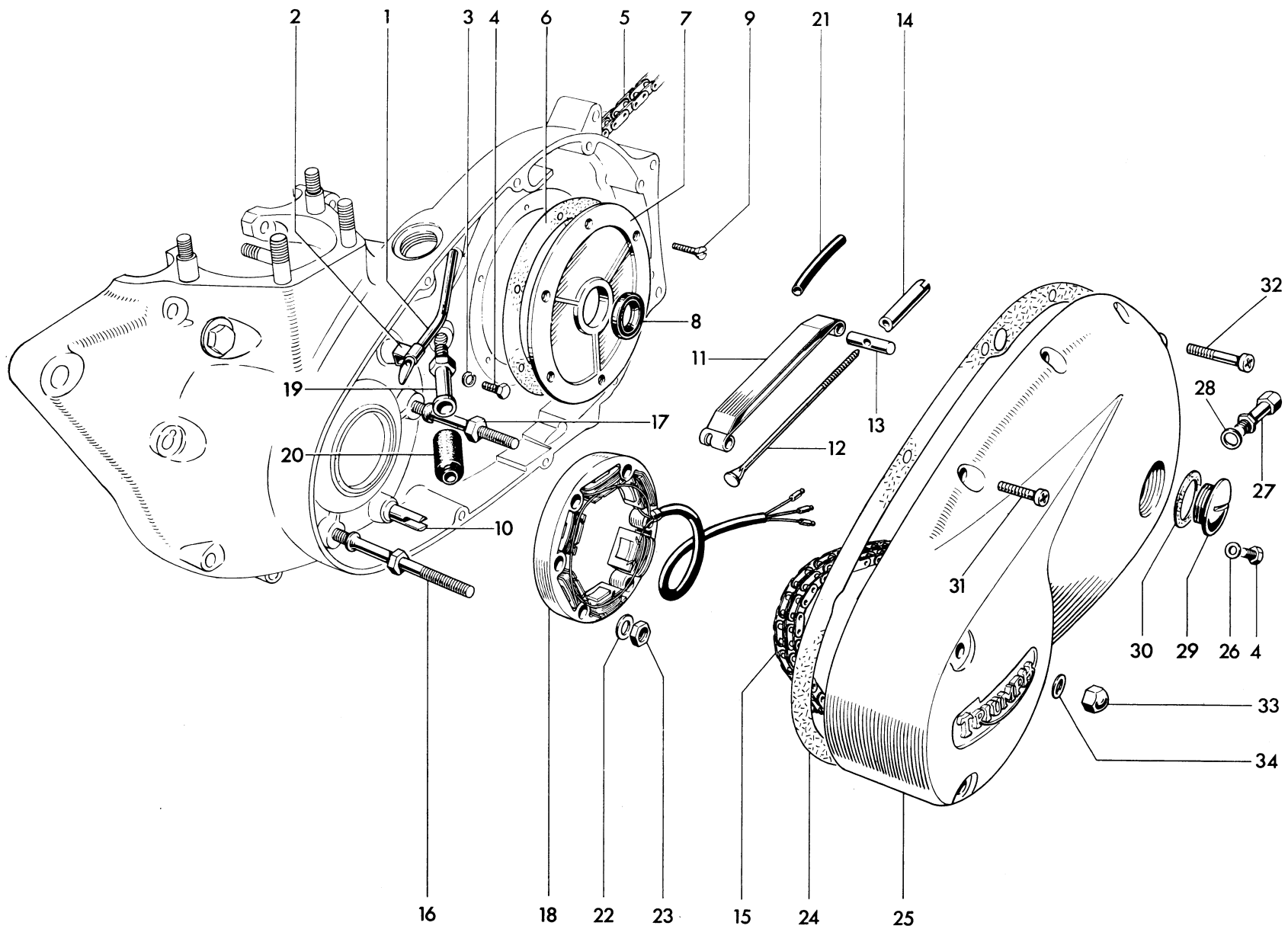

Fig. 11. CHAINCASE AND CHAINS

CHAINCASE AND CHAINS

			6T	TR6	T120
1	E4704	Primary chain oiler tube	1	1	1
2	E4705	Clip	1	1	1
3	S26-2 60-4250	Spring washer	1	1	1
4	DS57 82-9019	Bolt ($\frac{7}{16}$ in. U.H.)	2	2	2
5	D481	Rear chain, $\frac{5}{8}$ in. x $\frac{3}{8}$ in. x 103 links	1	1	1
6	E3832 71-1419	Joint washer	1	1	1
7	E4577	Cover plate	1	1	1
8	E4578	Oil seal	1	1	1
9	E3821	Countersunk screw ($\frac{5}{16}$ in. U.H.)	6	6	6
10	E4147 70-5087	Chain tensioner abutment	1	1	1
11	E4149	Chain tensioner blade	1	1	1
12	E4152	Tie rod	1	1	1
13	E4145	Trunnion	1	1	1
14	E4153 70-9703	Adjuster sleeve nut	1	1	1
15	D477	Primary chain, $\frac{3}{8}$ in. Duplex x 84 links	1	1	1
16	E4536	Stator stud	2	2	2
17	E4537	Stator stud	1	1	1
18	47162 47204	Stator, RM 19	1	-	-
18	47164 47197	Stator, RM 19	-	1	1
19	E4772	Sleeve nut	1	1	1
20	E4144	Rubber grommet	1	1	1
21	E5449	Plastic sleeve	1	1	1
22	S25-3 60-4247	Plain washer	3	3	3
23	E5324	Self-locking nut	3	3	3
24	T1770 71-1463	Joint washer	1	1	1
25	T1727 71-4072	Chaincase	1	1	1
26	E2441	Copper washer	1	1	1
27	E4922 70-6347	Drain and adjuster plug	1	1	1
28	T1738	Fibre washer	1	1	1
29	E732 57-2166	Filler plug	1	1	1
30	NE507 70-8782	Fibre washer	1	1	1
31	E4806	Screw ($\frac{29}{32}$ in. U.H.)	2	2	2
32	E3204	Screw (1 in. U.H.)	6	6	6
33	H1531	Domed nut	2	2	2
34	F1880	Copper washer	2	2	2

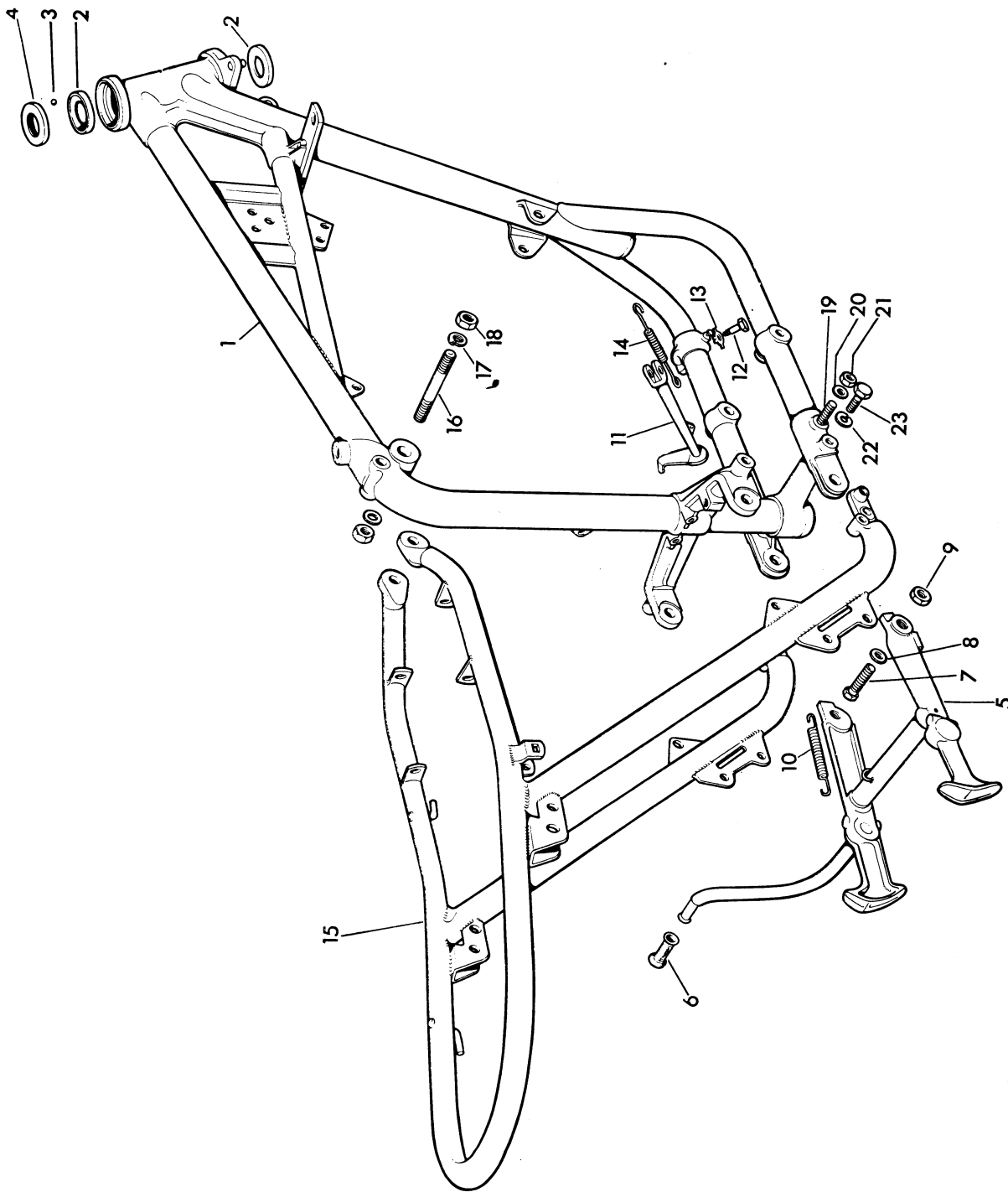

Fig. 12. FRAME

Ref. No.	Part No.	DESCRIPTION	QUANTITY		
FRAME					
			6T	TR6	T120
1	F5448	Front frame	1	1	1
2	H11182-6903	Steering race cup	2	2	2
3	S70-3 60-2364	Steel ball (1/4 in. diam.)	40	40	40
4	H1018	Top cone and dust cover	1	1	1
5	F5928	Centre stand (3.50 rear tyre)... ..	1	-	1
5	F5932	Centre stand (4.00 rear tyre)... ..	-	1	-
6	T449 57-2450	Pedal rubber	1	1	1
7	F5678	Pivot bolt	2	2	2
8	F5679	Plain washer	2	2	2
9	F2725	Nut	2	2	2
10	F4671	Return spring	1	1	1
11	F4388 82-7357	PROP STAND COMPLETE (3.50 rear tyre)	1	-	1
11	F4712 82-7373	PROP STAND COMPLETE (4.00 rear tyre)	-	1	-
12	F3097	Pivot bolt	1	1	1
13	F3096	Tab washer	1	1	1
14	F2610	Return spring	1	1	1
15	F5449 82-6443	Rear frame	1	1	1
16	F4510	Stud (4 3/8 in. O.A.) (when panels are fitted)	1	-	-
16	F2842	Stud (3 7/8 in. O.A.)	-	1	1
17	S26-1 60-4259	Spring washer	2	2	2
18	S1-52 60-4261	Nut	2	2	2
19	F5411	Bolt (3 in. U.H.)	2	2	2
20	S25-6 37-2027	Plain washer	2	2	2
21	DS47 60-4268	Nut	2	2	2
22	PCW73A 60-4251	Spring washer	2	2	2
23	F5605	Bolt (1 3/8 in. U.H.)	2	2	2

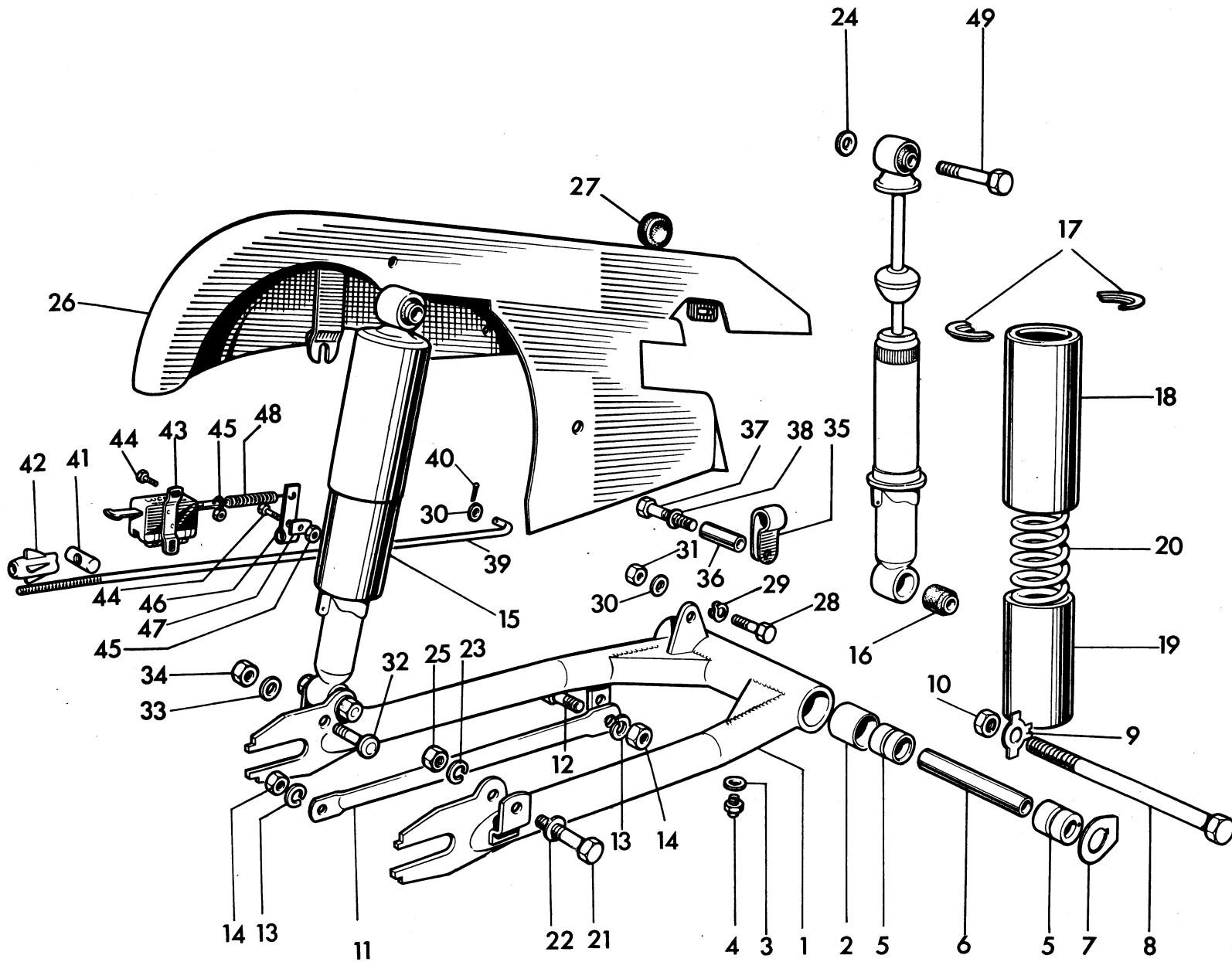

Fig. 13. SWINGING FORK AND SUSPENSION UNITS

SWINGING FORK AND SUSPENSION UNITS

			6T	TR6	T120
1	F5302	SWINGING FORK	1	1	1
2	F6042	Pivot bush	2	2	2
3	NW10060-1841	Grease nipple	1	1	1
4	WE17060-4263	Fibre washer	1	1	1
5	F5312 83-6821	Sleeve	2	2	2
6	F5313	Distance tube	1	1	1
7	F5311 82-6730	End plate	2	2	2
8	F6150	Bolt (8 $\frac{3}{8}$ in. U.H.)	1	1	1
9	F5944	Tab washer	1	1	1
10	NT297 99-3542	Nut	1	1	1
11	F3774	Brake torque stay	1	1	1
12	F5315	Bolt (3 $\frac{1}{2}$ in. U.H.)	1	1	1
13	PCW73A 60-4261	Spring washer	2	2	2
14	DS47 60-4268	Nut	2	2	2
15	†64054506	SUSPENSION UNIT	2	-	2
15	†64054164	SUSPENSION UNIT	-	2	-
16	9054/316A	Bonded bush	4	4	4
17	9054/171	Spring retainer	4	4	4
18	9054/151	Outer dirt shield	2	2	2
19	9054/47	Inner dirt shield	2	2	2
20	SA253/5	Spring, 145 lbs. Blue/Yellow	2	-	2
20	9054/280	Spring, 100 lbs. Green/Green	-	2	-
21	E2113	Unit fixing bolt (1 $\frac{5}{16}$ in. U.H.)	3	4	4
22	S25-2 60-4246	Plain washer	2	2	2
23	S26-1 60-4259	Spring washer	2	2	2
24	GS308 70-8770	Plain washer	-	2	2
25	P0172A 99-0047	Nut	2	4	4
26	F5737 82-7067	Chainguard	1	1	1
27	F5536	Grommet	1	1	1
28	F4135	Pivot bolt	1	1	1
29	F2277	Spring washer	1	1	1
30	S25-13 60-4248	Plain washer	2	2	2
31	E5269	Self-locking nut	1	1	1
32	F4136	Stepped bolt	1	1	1
33	S25-3 60-4247	Plain washer	1	1	1
34	S1-51 60-4261	Nut	1	1	1
35	F3808	Clip	1	1	1
36	F5741	Distance piece	1	1	1
37	E3872	Bolt (1 $\frac{1}{2}$ in. U.H.)	1	1	1
38	S26-2 60-4250	Spring washer	1	1	1
39	F3597 83-1925	Brake operating rod	1	1	1
40	1 $\frac{1}{8}$ in. x 3 $\frac{3}{8}$ in.	Split pin	1	1	1
41	W11	Pivot pin... ..	1	1	1
42	F4585	Adjuster nut	1	1	1
43	31437 54033234	Stop lamp switch, type 22B	1	1	1
44	T1076	Screw (3 $\frac{3}{8}$ in. U.H.)	3	3	3
45	F4717	Self locking nut	3	3	3
46	F5412	Switch lever	1	1	1
47	F5413	"D" washer	1	1	1
48	315738	Spring (F.3158)	1	1	1
49	F5729	Bolt	1	-	-
	†SB4/275	Sidecar suspension unit		as required	

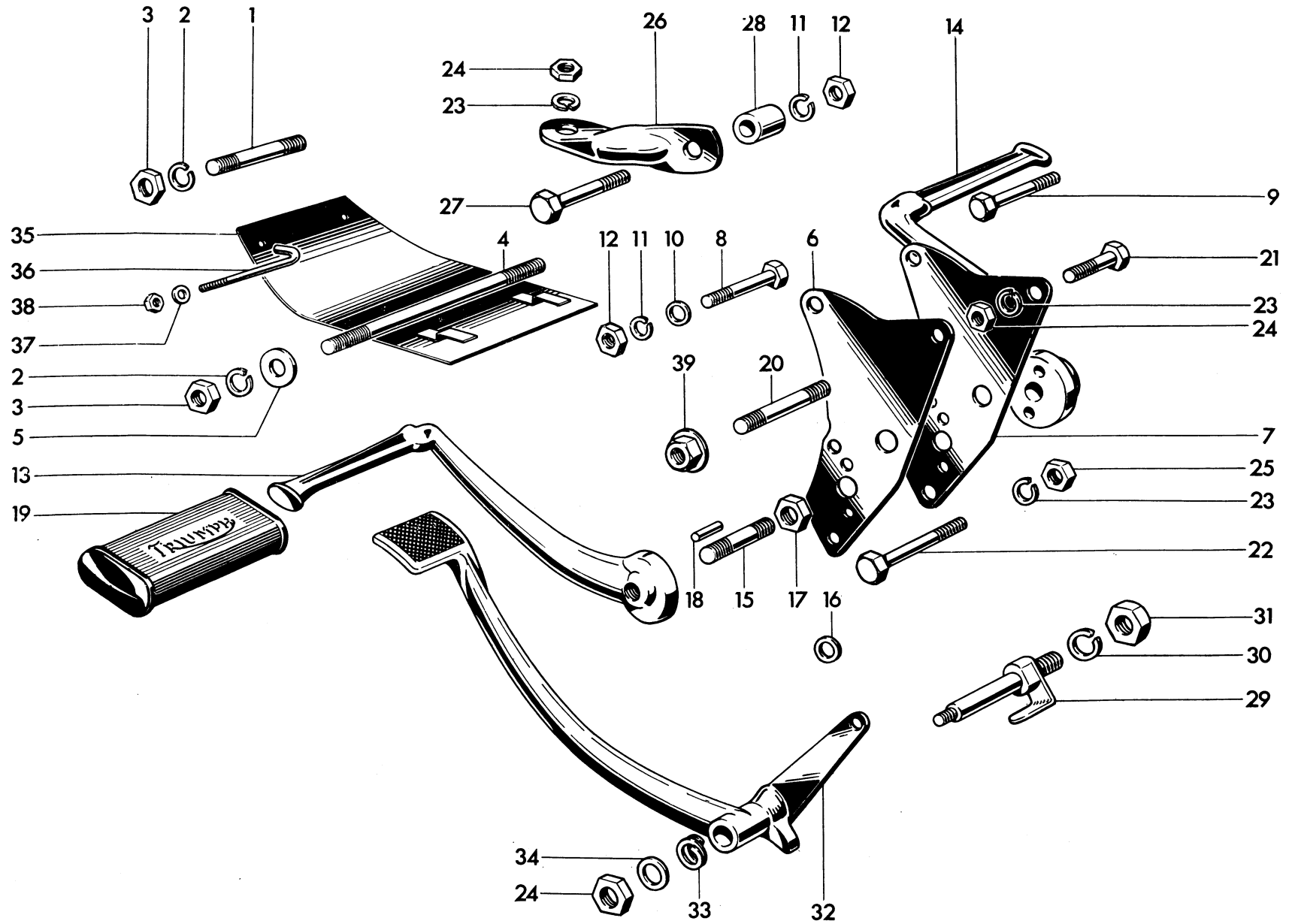

Fig. 14. ENGINE UNIT FITTINGS AND FOOTRESTS

ENGINE UNIT FITTINGS AND FOOTRESTS

			6T	TR6	T120
1	F5469	Stud (3 $\frac{5}{8}$ in. O.A.)	1	1	1
2	PCW73A60-4251	Spring washer	4	4	4
3	DS47 60-4268	Nut	4	4	4
4	F5259	Stud (8 $\frac{3}{8}$ in. O.A.)	1	1	1
5	F5532	Distance piece	2	2	2
6	F5907	Left rear engine plate	1	1	1
7	F5908	Right rear engine plate	1	1	1
8	E4165	Bolt (1 $\frac{1}{8}$ in. U.H.)	2	2	2
9	F5316	Bolt (1 $\frac{7}{8}$ in. U.H.)	2	2	2
10	S25-360-4247	Plain washer	4	4	4
11	S26-360-4260	Spring washer	6	6	6
12	S1-5121-0001/051	Nut	6	6	6
13	F5909 82-6069	Left footrest	1	1	1
14	F5910	Right footrest	1	1	1
15	F5942	Stud (1 $\frac{9}{16}$ in. O.A.)	2	2	2
16	S25-637-2023	Plain washer	2	2	2
17	S4-1321-0001/013	Nut	2	2	2
18	F5943	Peg	4	4	4
19	NF70482-9279	Footrest rubber	2	2	2
20	F5351	Stud (1 $\frac{3}{8}$ in. O.A.)	2	-	-
20	E3114	Stud (1 $\frac{3}{8}$ in. O.A.)	-	2	2
21	H211	Bolt (1 $\frac{1}{8}$ in. U.H.)	-	1	1
21	H426	Bolt (2 $\frac{3}{8}$ in. U.H.)	2	1	1
22	F1760	Bolt (1 $\frac{1}{8}$ in. U.H.)	2	2	2
23	S26-160-4259	Spring washer	8	8	8
24	S1-5260-4261	Nut	7	7	7
25	P0172A99-0047	Nut	2	2	2
26	E4778	Engine torque stay	4	4	4
27	F3805	Bolt (1 $\frac{5}{8}$ in. U.H.)	2	2	2
28	F3069 82-9092	Distance piece	4	4	4
29	F5604	Brake pedal spindle	1	1	1
30	SCZ45 82-8245	Spring washer	1	1	1
31	DS48 99-3557	Nut	1	1	1
32	F5242	Brake pedal	1	1	1
33	S26-160-3541	Spring washer	1	1	1
34	S25-260-4246	Plain washer	1	1	1
35	F5472	Crankcase undershield...	-	1	-
36	F5788	Hook bolt	-	2	-
37	S25-160-4245	Plain washer	-	2	-
38	F879	Nut	-	2	-
39	F3771	Nut	2	2	2

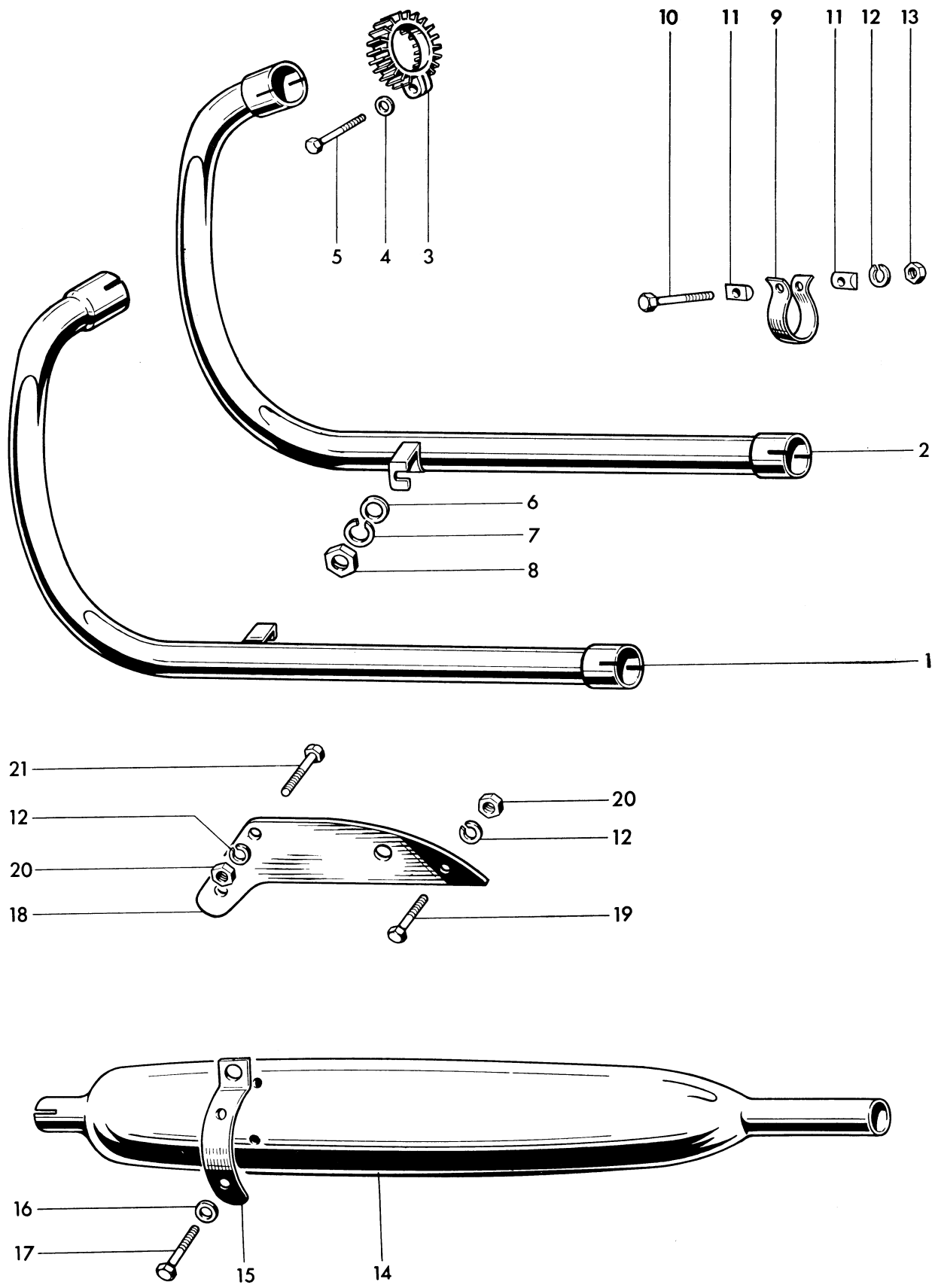

Fig. 15. EXHAUST PIPES AND SILENCERS

EXHAUST PIPES AND SILENCERS

			6T	TR6	T120
1	E4716 70-5957	Left exhaust pipe	1	1	1
2	E4718 70-5958	Right exhaust pipe	1	1	1
3	E4501 71-0216	Finned clip	2	2	2
4	E410A 70-8860	Hemispherical washer	2	2	2
5	E409	Bolt (1 $\frac{3}{16}$ in. U.H.)	2	2	2
6	F4370	Plain washer	1	1	1
7	PCW73A 60-4251	Spring washer	2	2	2
8	DS47 60-4268	Nut	2	2	2
9	E2271	Clip	2	2	2
10	F3430	Bolt (1 $\frac{3}{8}$ in. U.H.)	2	2	2
11	E3768	"D" washer	4	4	4
12	S26-3 60-4260	Spring washer	8	8	8
13	E1310	Nut	2	2	2
14	E4949	Silencer	2	2	2
15	E4951	Bracket	2	2	2
16	S25-3 60-4247	Plain washer	4	4	4
17	F929	Bolt ($\frac{1}{2}$ in. U.H.)	4	4	4
18	E4711	Pillion footrest support	2	2	2
19	F2335	Bolt ($\frac{1}{8}$ in. U.H.)	2	2	2
20	SI-5121-0001/051	Nut	6	6	6
21	DS58 99-3518	Bolt ($\frac{3}{8}$ in. U.H.)	2	2	2

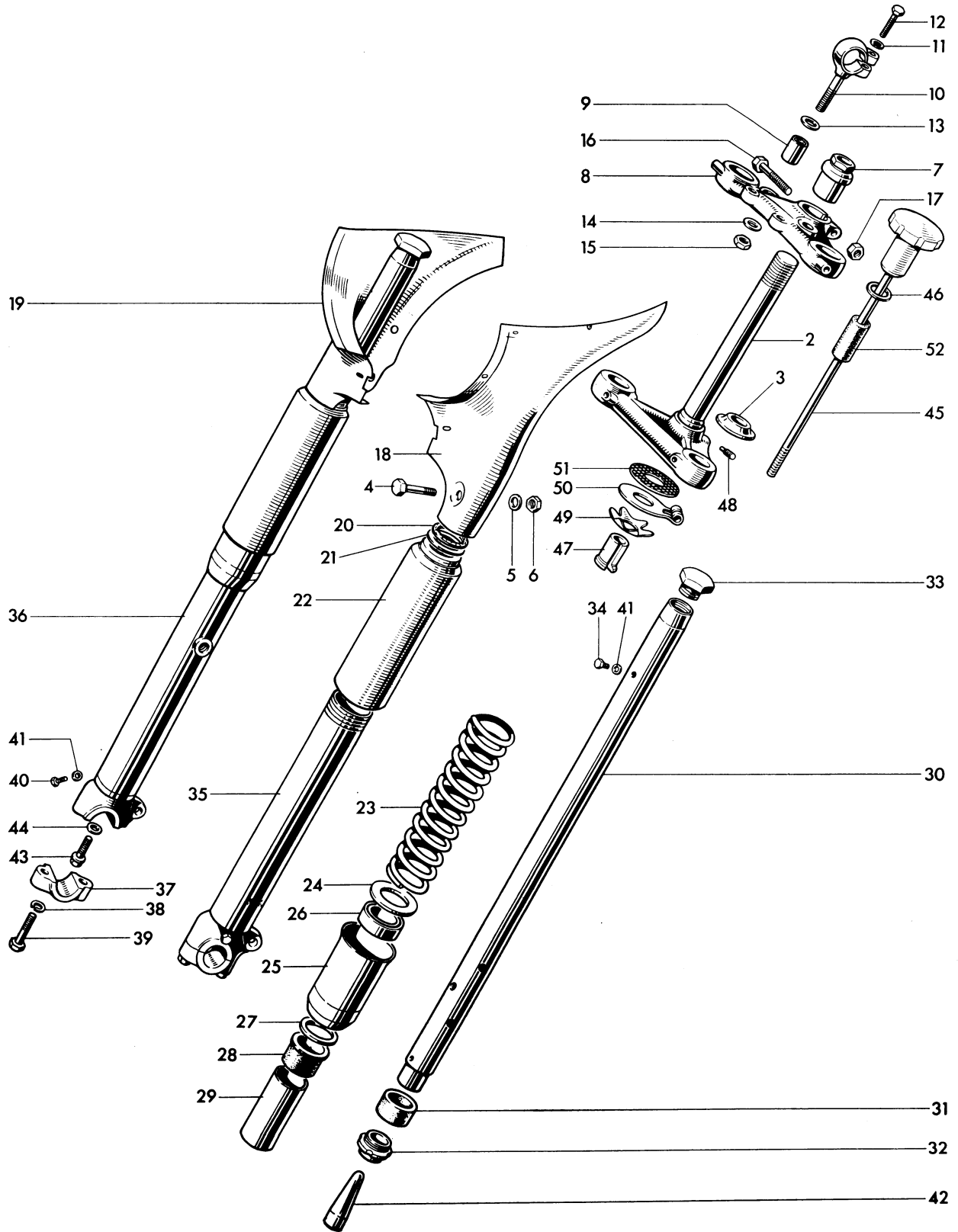

Fig. 16. TELESCOPIC FRONT FORK, 6T

Ref. No.	Part No.	DESCRIPTION	QUANTITY
		TELESCOPIC FRONT FORK, 6T	
1	H1727	FORK ASSEMBLY	1
2	H1577	Middle lug and stem	1
3	H439	Bottom cone	1
4	H941	Pinch bolt (2¼ in. U.H.)	2
5	S25-260-4246	Plain washer	2
6	E2412	Nut	2
7	H1141	Fork stem sleeve nut	1
8	H1528 97-1528/001	TOP LUG ASSEMBLY	1
9	H1527	Bonded bush	2
10	H1523 97-2291	Handlebar eyebolt	2
11	F1335	Plain washer	2
12	H1340	Bolt (1½ in. U.H.)	2
13	H1708	Plain washer	2
14	H1529	Hemispherical washer	2
15	F3955	Self locking nut	2
16	F1760	Pinch bolt (1⅞ in. U.H.)	1
17	H379	Seated nut	1
18	H1290	Left nacelle cover	1
19	H1291	Right nacelle cover	1
20	H1756	Felt washer	2
21	H1745	Plain washer	2
22	H1661 97-1914/043	Upper cover tube	2
23	H1660	Solo main spring (Unpainted)	2
23	H1697	Sidecar main spring (Yellow/White)	2
24	H1656	Plain washer	2
25	H1654	DUST EXCLUDER SLEEVE NUT	2
26	H1500	Oil seal	2
27	H431	Plain washer	2
28	H441	Top bearing	2
29	H1653	Damping sleeve	2
30	H1695 97-1981	STANCHION c/w BEARING	2
31	H443	Lower bearing	2
32	H1058	Bearing nut	2
33	H1659 97-1762	Cap nut	2
34	H519A 97-0519/001	Oil filler plug (¾ in.)	2
35	H1650 97-1650/043	LEFT BOTTOM MEMBER c/w CAP	2
36	H1651 97-1651/043	RIGHT BOTTOM MEMBER c/w CAP	1
37	H1053	Spindle cap	2
38	S26-3 60-4260	Spring washer	1
39	H1070	Cap bolt (1⅞ in. U.H.)	4
40	H1071	Drain plug	2
41	H430	Fibre washer	4
42	H1499	Restrictor	2
43	H1063	Flanged bolt (2⅜ in. U.H.)	2
44	H1062	Aluminium washer	2
45	H1142 97-1142/043	Steering damper rod c/w knob	1
46	H565	Plain washer	1
47	H408	Adjuster sleeve	1
48	H1286	Locating pin	1
49	H95	Spring plate	1
50	H413	Anchor plate	1
51	H435	Friction disc	1
52	H1618	Rubber sleeve	1

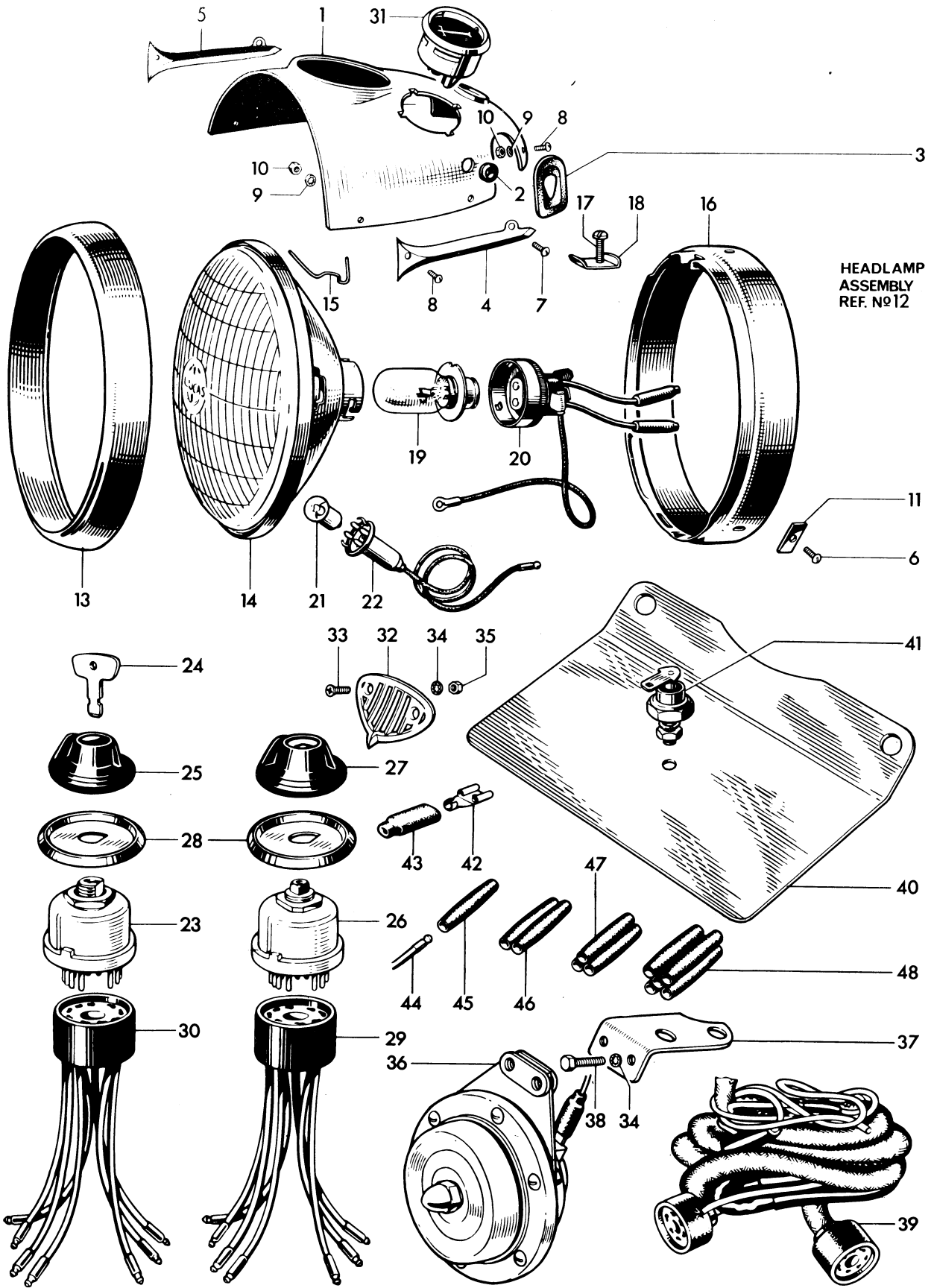

Fig. 17. NACELLE HEADLAMP AND SWITCHES

Ref. No.	Part No.	DESCRIPTION	QUANTITY
----------	----------	-------------	----------

NACELLE HEADLAMP AND SWITCHES

1	H1781 <i>97-178/043</i>	Nacelle top	6T 1
2	H961 <i>199002</i>	Rubber grommet	3
3	H669	Rubber grommet	2
4	H877	Left motif	1
5	H878	Right motif	1
6	H689	Screw ($\frac{1}{4}$ in. U.H.)	4
7	H687	Screw ($\frac{3}{8}$ in. U.H.)	2
8	H688	Screw ($\frac{5}{16}$ in. U.H.)	2
9	E2880	Serrated washer	4
10	H691	Nut	4
11	H690	Nut	2
12	59176 <i>N.L.A.</i>	HEADLAMP	1
13	553248	Rim	1
14	516812 <i>54525927</i>	Light unit	1
15	504665	Fixing wire... ..	6
16	553267	Fixing ring	1
17	144921	Screw	1
18	534296	Plate	1
19	414	Bulb (50/40 W. L.H. dipping. Pre-focus)	1
20	554602	Adaptor	1
21	222 <i>989</i>	Bulb (4W.M.C.C.)	1
22	554710	Pilot bulbholder	1
23	34427	IGNITION SWITCH c/w KEY, type 88SA	1
24	54336176	Ignition key	1
25	54336178	Ignition switch cover	1
26	34289	Lighting switch, type 88SA	1
27	54330934	Knob c/w screw	1
28	54330576	Switch bezel plate	2
29	54930007	Replacement harness socket (lighting)	A
30	54930008	Replacement harness socket (ignition)	A
31	36296 <i>36403</i>	Ammeter, type 2AR	1
32	H992	Horn grille	1
33	H993	Screw (0.540 in. U.H.)	2
34	GS29960-4256	Serrated washer	4
35	F3799	Nut	2
36	H1420	Horn bracket	1
37	70164	Horn, type 8H	1
38	F4771	Bolt ($\frac{1}{2}$ in. U.H.)	2
39	54094523 <i>Dix</i>	Wiring harness	1
40	F5762	Mounting plate	1
41	49345	Zener diode	1
42	54942078549606	Lucar connector	2
43	54190042	Insulating cover... ..	2
44	900269	Snap connector terminal	as required
45	900288	Single snap connector	as required
46	850641	Double snap connector	as required
47	850844	Triple snap connector	as required
48	850832	Quintuple snap connector	as required

ASSEMBLY REF. No.1

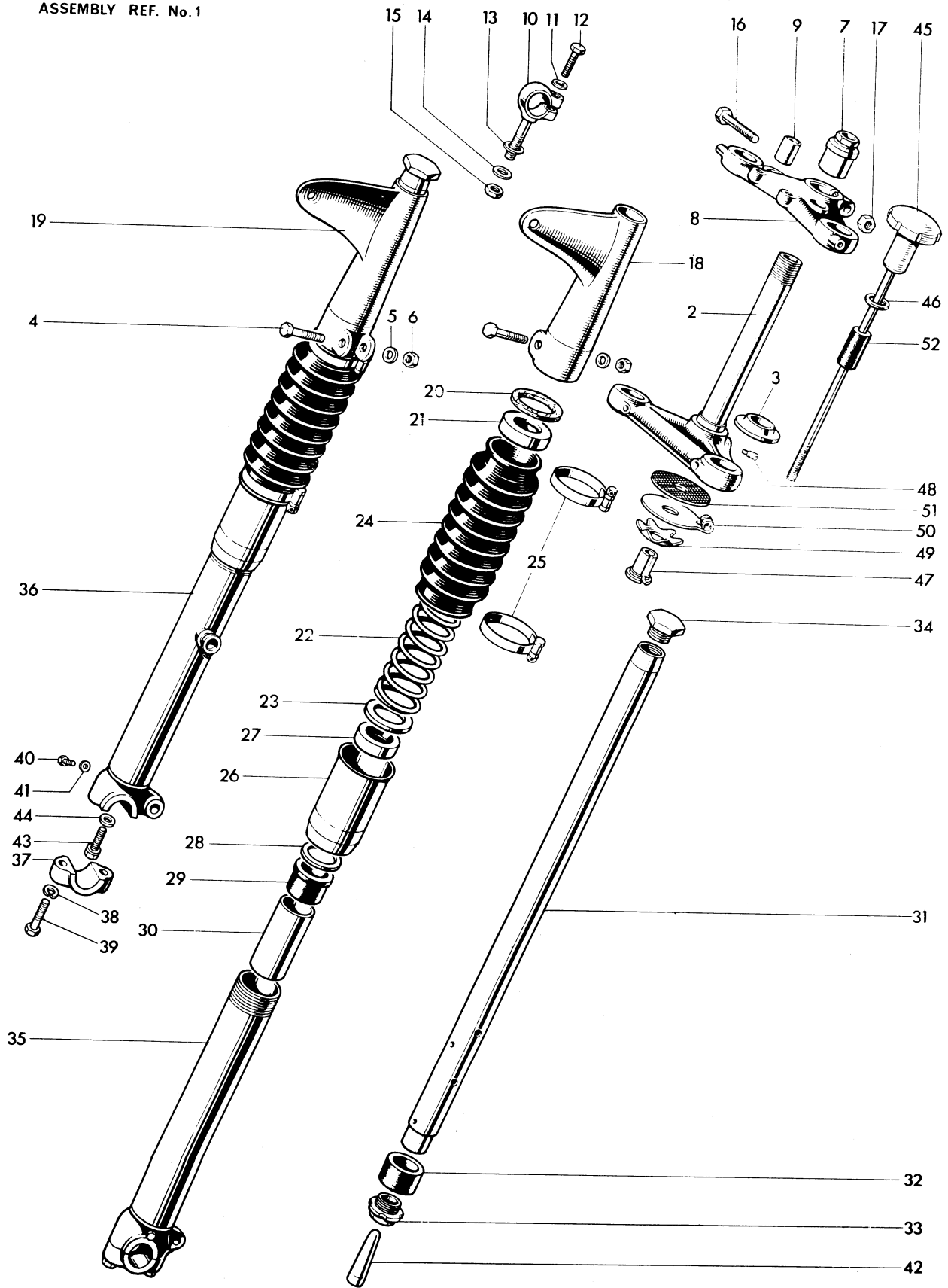

Fig. 18. TELESCOPIC FRONT FORK, TR6 AND T120

TELESCOPIC FRONT FORK, TR6 AND T120

			TR6	T120
1	H1715 97-2070	FORK ASSEMBLY	1	1
2	H1577 97-1999	Middle lug and stem	1	1
3	H439	Bottom cone	1	1
4	H941	Pinch bolt (2¼ in. U.H.)	2	2
5	S25-2 60-4246	Plain washer	2	2
6	E2412	Nut	2	2
7	H405	Fork stem sleeve nut	1	1
8	H1528A 97-1529/001	TOP LUG ASSEMBLY	2	2
9	H1527	Bonded bush	2	2
10	H1523 97-2291	Handlebar eyebolt	2	2
11	F1335	Plain washer	2	2
12	H1340	Bolt (1⅛ in. U.H.)	2	2
13	H1708	Plain washer	2	2
14	H1529	Hemispherical washer	2	2
15	F3955	Self-locking nut	2	2
16	F1760	Pinch bolt (1⅞ in. U.H.)	1	1
17	H379	Seated nut	1	1
18	H1646	Left top cover	1	1
19	H1647	Right top cover	1	1
20	H1756	Felt washer	2	2
21	H1657	Spring abutment	2	2
22	H1660	Solo main spring (Unpainted)	2	2
22	H1697	Sidecar main spring (Yellow/White)	2	2
23	H1656	Plain washer	2	2
24	H1645	Telescopic gaiter	2	2
25	D340	Gaiter clip	4	4
26	H1654	DUST EXCLUDER SLEEVE NUT	2	2
27	H1500	Oil seal	2	2
28	H431	Plain washer	2	2
29	H441	Top bearing	2	2
30	H1653	Damping sleeve	2	2
31	H1649	STANCHION c/w BEARING	2	2
32	H443	Lower bearing	2	2
33	H1058	Bearing nut	2	2
34	H1658	Cap nut	2	2
35	H1650 97-1650/043	LEFT BOTTOM MEMBER c/w CAP	1	1
36	H1651 97-1651/043	RIGHT BOTTOM MEMBER c/w CAP	1	1
37	H1053	Spindle cap	2	2
38	S26-3 60-4260	Spring washer	4	4
39	H1070	Cap bolt (1⅞ in. U.H.)	4	4
40	H1071	Drain plug	2	2
41	H430	Fibre washer	2	2
42	H1499	Restrictor	2	2
43	H1063	Flanged bolt (2⅜ in. U.H.)	2	2
44	H1062	Aluminium washer	2	2
45	H1142 97-1142/043	Steering damper rod c/w knob	1	1
46	H565	Plain washer	1	1
47	H408	Adjuster sleeve	1	1
48	H1286	Locating pin	1	1
49	H95	Spring plate	1	1
50	H413	Anchor plate	1	1
51	H435	Friction disc	1	1
52	H1618	Rubber sleeve	1	1

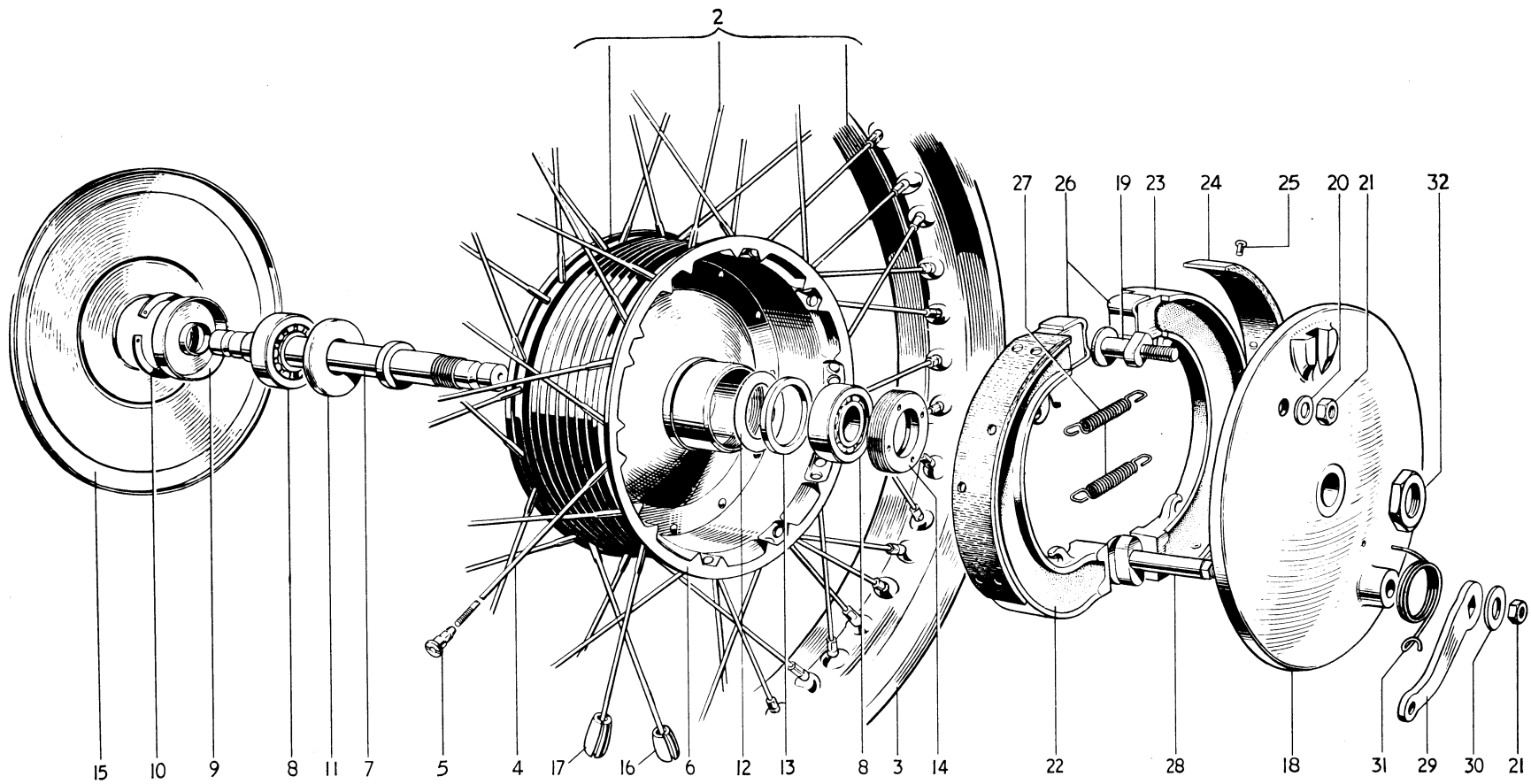

Fig. 19. FRONT WHEEL

Ref. No.	Part No.	DESCRIPTION	6T	TR6	T120
FRONT WHEEL					
1	W1399	FRONT WHEEL COMPLETE	1	-	1
1	W1323	FRONT WHEEL COMPLETE	-	1	-
2	W1371 <i>37-1721</i>	RIM, SPOKES AND HUB ASSEMBLY	1	-	1
2	W1324 <i>37-1721</i>	RIM, SPOKES AND HUB ASSEMBLY	-	1	-
3	W1374	Front wheel rim (WM2-18)	1	-	1
3	W1230	Front wheel rim (WM2-19)	-	1	-
4	W1275	Spoke (8/10G x 5 $\frac{1}{8}$ in. straight) c/w nipple	40	-	40
4	W1328	Spoke (8/10G x 5 $\frac{5}{8}$ in. straight) c/w nipple	-	40	-
5	S79-2 <i>37-4200</i>	Spoke nipple	40	40	40
6	W1325	Hub and brake drum	1	1	1
7	W1239	Wheel spindle	1	1	1
8	W653	Bearing	2	2	2
9	W1237	Dust cover	1	1	1
10	T280	Circlip	1	1	1
11	W1481	Grease retainer	1	1	1
12	W1474	Grease retainer (brake side)	1	1	1
13	W1238	Backing ring	1	1	1
14	W582	Retaining ring	1	1	1
15	W1332	Cover plate	1	1	1
16	W1197	Balance weight, $\frac{1}{2}$ oz.		as required	
17	W1198	Balance weight, 1 oz.		as required	
18	W1330	Brake anchor plate	1	1	1
19	W1302	Fulcrum pin	1	1	1
20	S25-2 <i>60-4246</i>	Plain washer	1	1	1
21	S1-52 <i>60-4261</i>	Nut	2	2	2
22	W1410	LEADING BRAKE SHOE c/w LINING	1	1	1
23	W1411	TRAILING BRAKE SHOE c/w LINING	1	1	1
24	W1414 <i>N.L.A.</i>	Brake lining	2	2	2
25	W129	Brass rivet	16	16	16
26	W1415 <i>37-4071</i>	Pivot pad	2	2	2
27	W135	Shoe return spring	2	2	2
28	W1243	Brake cam	1	1	1
29	W1331 <i>37-1331/034</i>	Brake cam lever	1	1	1
30	S25-6 <i>37-2027</i>	Plain washer	1	1	1
31	W592	Lever return spring	1	1	1
32	W1246	Anchor plate nut	1	1	1

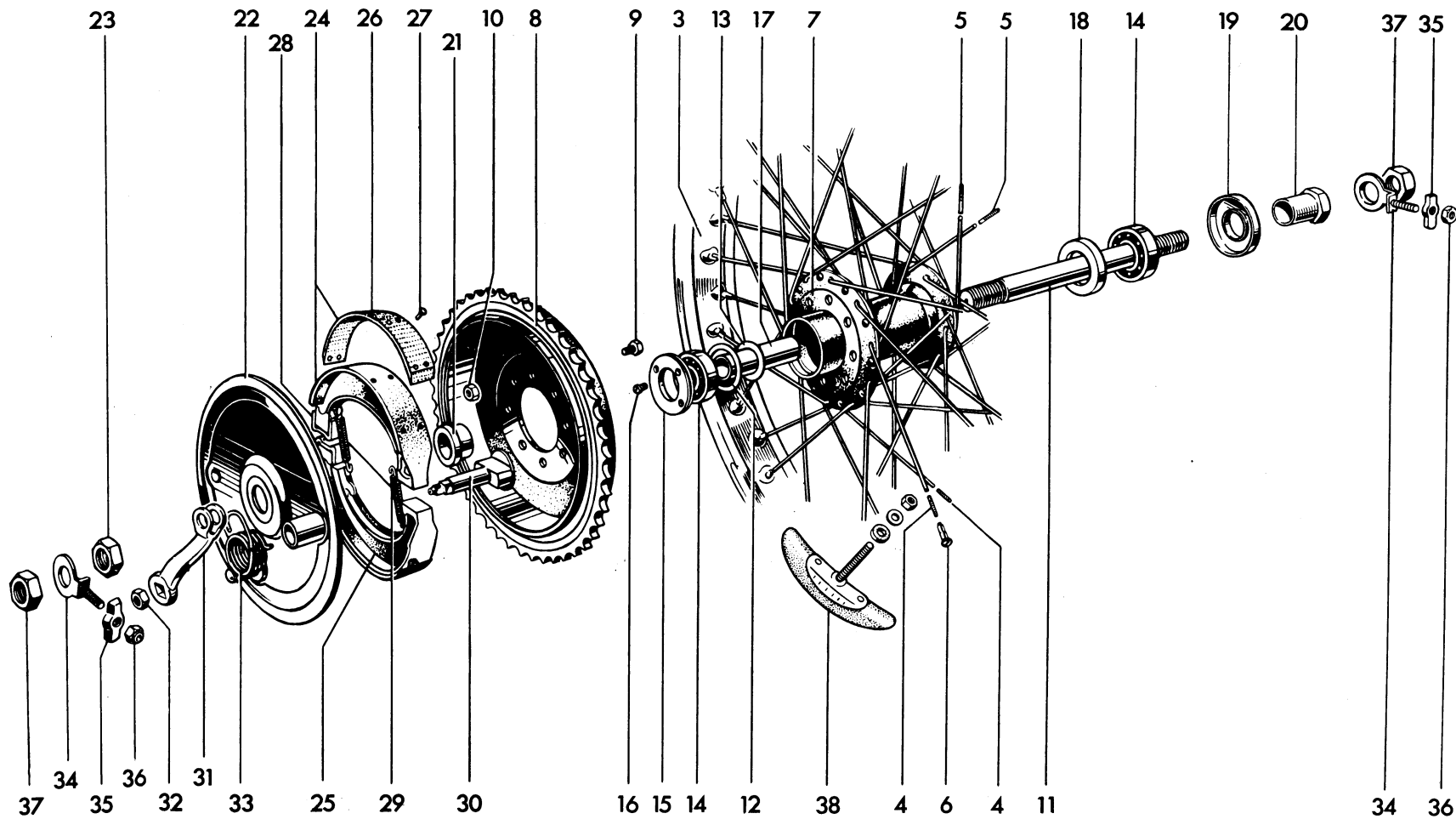

Fig 20. REAR WHEEL

Ref. No.	Part No.	DESCRIPTION	QUANTITY	6T	TR6	T120
REAR WHEEL						
1	W1469	REAR WHEEL COMPLETE	1	-	1	
1	W1491 37-1721	REAR WHEEL COMPLETE	-	1	-	
2	W1470	RIM, SPOKES AND HUB ASSEMBLY	1	-	1	
2	W1486 37-3610	RIM, SPOKES AND HUB ASSEMBLY	-	1	-	
3	W1471	Rear wheel rim (WM2-18)	1	-	1	
3	W1007	Rear wheel rim (WM3-18)	-	1	-	
4	W1107	Spoke (8/10G x 7 $\frac{3}{16}$ in. 90°) c/w nipple	20	20	20	
5	W1108	Spoke (8/10G x 7 $\frac{3}{8}$ in. 90°) c/w nipple	20	20	20	
6	S79-2 37-4200	Spoke nipple	40	40	40	
7	W1472	Hub	1	1	1	
8	W951	Sprocket and brake drum (46T)	1	1	1	
9	W62 37-1690	Sprocket to hub bolt ($\frac{1}{16}$ in. U.H.)	8	8	8	
10	W1495	Self-locking nut	8	8	8	
11	W1281 37-3589	Wheel spindle	1	1	1	
12	W1022	Backing ring	1	1	1	
13	W1474	Grease retainer	1	1	1	
14	W653	Bearing	2	2	2	
15	W1021 99-0057	RETAINER RING	1	1	1	
16	W1079	Locking screw ($\frac{5}{16}$ in. U.H.)	1	1	1	
17	W1278	Distance tube	1	1	1	
18	W583 37-1654	Grease retainer	1	1	1	
19	W1475	Dust cover	1	1	1	
20	W1478	Nut	1	1	1	
21	W1024	Distance piece	1	1	1	
22	W1112	Brake anchor plate	1	1	1	
23	F1747	Nut	1	1	1	
24	W1406	LEADING BRAKE SHOE c/w LINING	1	1	1	
25	W1407	TRAILING BRAKE SHOE c/w LINING	1	1	1	
26	NW243 99-0001	Brake lining	2	2	2	
27	W129	Brass rivet	16	16	16	
28	W1415 37-4071	Pivot pad	2	2	2	
29	W135	Shoe return spring	2	2	2	
30	W1083 37-3592	Brake cam	1	1	1	
31	W1487	Brake cam lever	1	1	1	
32	S1-52 60-4261	Nut	1	1	1	
33	W1488	Lever return spring	1	1	1	
34	W1134 37-2089	Chain adjuster	2	2	2	
35	W1015	Adjuster end plate	2	2	2	
36	W1058 70-8137	Self locking nut	2	2	2	
37	F1747	Spindle nut	2	2	2	
38	D106 WM2-58	Tyre security bolt	2	-	2	
38	WM3 37-3468	Tyre security bolt	-	2	-	

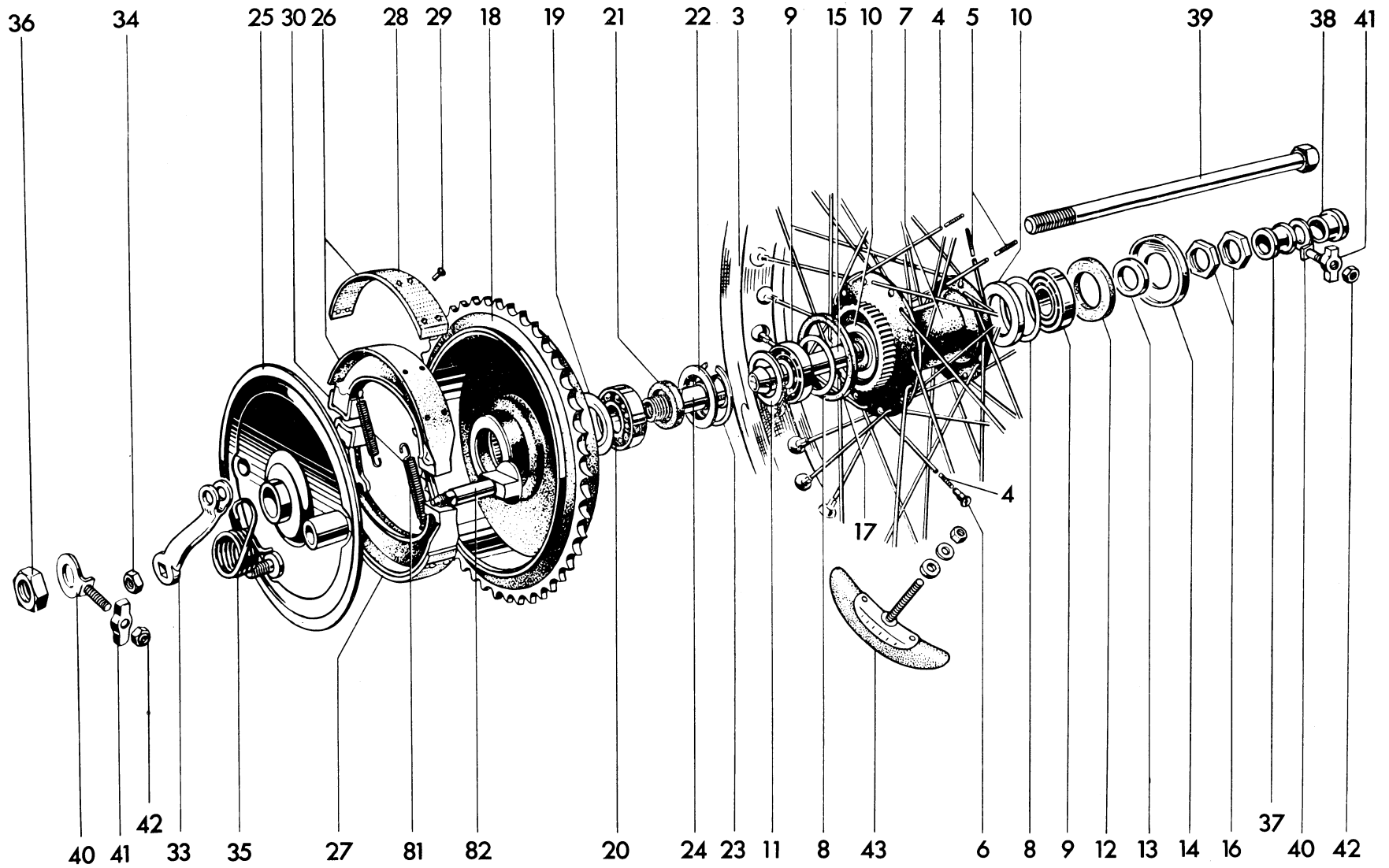

Fig. 21. QUICKLY DETACHABLE REAR WHEEL

Ref. No.	Part No.	DESCRIPTION	6T	TR6	T120
QUICKLY DETACHABLE REAR WHEEL					
1	W1310 37-1600	Q.D. REAR WHEEL COMPLETE	1	1	1
2	W1099	RIM, SPOKES AND HUB ASSEMBLY	1	1	1
3	W1007	Rear wheel rim (WM3-18)	1	1	1
4	W1107	Spoke (8/10G x 7 ⁹ / ₁₆ in. 90°) c/w nipple	20	20	20
5	W1108	Spoke (8/10G x 7 ⁷ / ₈ in. 90°) c/w nipple	20	20	20
6	S79-2 37-4200	Spoke nipple	40	40	40
7	W1100	Hub	1	1	1
8	W1033	Backing ring	2	2	2
9	W1034	Taper roller bearing complete	2	2	2
10	W1480	Grease retainer	2	2	2
11	W1035	Dust cap	1	1	1
12	W1036	Felt washer	1	1	1
13	W1037	Distance piece	1	1	1
14	W1038	Dust cap	1	1	1
15	W1039	Bearing sleeve	1	1	1
16	E398	Bearing adjuster nut	2	2	2
17	W1091	Rubber sealing ring	1	1	1
18	W1040	Sprocket and brake drum (46T)	1	1	1
19	W1143	Grease retainer	1	1	1
20	W1041	Bearing	1	1	1
21	W1042	Felt washer	1	1	1
22	W1043	Bearing and felt retainer	1	1	1
23	W1044	Circlip	1	1	1
24	W1045	Bearing sleeve	1	1	1
25	W1121	Brake anchor plate	1	1	1
26	W1406	LEADING BRAKE SHOE c/w LINING	1	1	1
27	W1407	TRAILING BRAKE SHOE c/w LINING	1	1	1
28	NW243 99-0001	Brake lining	2	2	2
29	W129	Brass rivet	16	16	16
30	W1415 37-4071	Pivot pad	2	2	2
31	W135	Shoe return spring	2	2	2
32	W1083 37-3592	Brake cam	1	1	1
33	W1487	Brake cam lever	1	1	1
34	S1-52 60-4261	Nut	1	1	1
35	W1488	Lever return spring	1	1	1
36	W1052	Nut	1	1	1
37	W1053	Inner distance piece	1	1	1
38	W1170	Outer distance piece	1	1	1
39	W1055	Spindle	1	1	1
40	W1135	Chain adjuster	2	2	2
41	W1015	Adjuster end plate	2	2	2
42	W1058 70-8137	Self locking nut	2	2	2
43	WM3 37-3468	Tyre security bolt	2	2	2

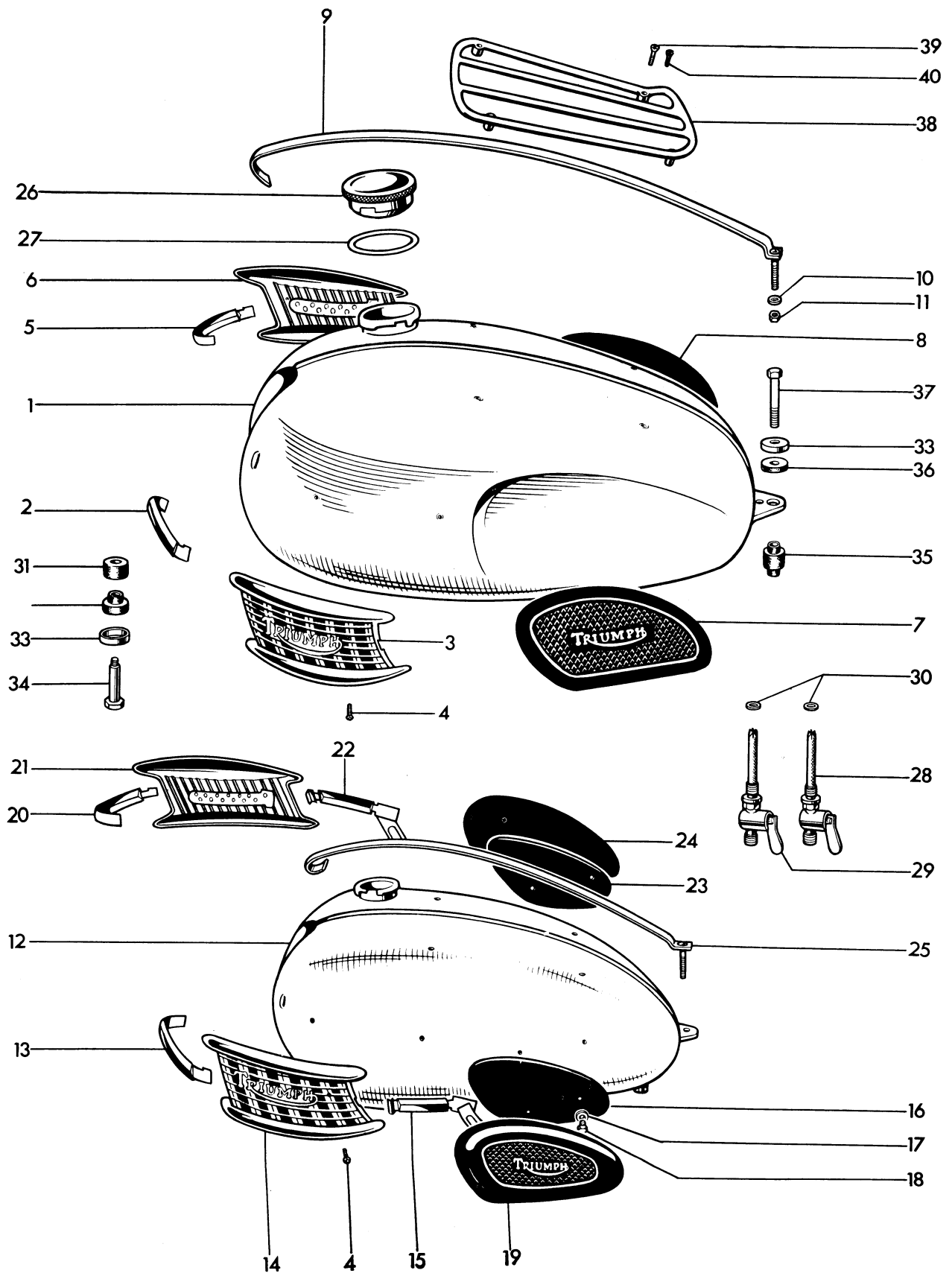

Fig. 22. PETROL TANKS

Ref. No.	Part No.	DESCRIPTION	QUANTITY		
PETROL TANKS					
			6T	TR6	T120
1	F5260	Petrol tank (4 gallons)	1	1	1
2	F4148	Styling strip (left, front)	1	1	1
3	F4766 ^{82-4766/049}	Styling unit (left)	1	1	1
4	F4129	Styling unit screw (0.435 in. U.H.)	4	4	4
5	F4151	Styling strip (right front)	1	1	1
6	F4767 ^{82-4767/049}	Styling unit (right)	1	1	1
7	F5401	Left knee grip	1	1	1
8	F5402	Right knee grip	1	1	1
9	F5398	Centre styling strip	1	1	1
10	F4019	Serrated washer	1	1	1
11	H919	Nut	1	1	1
12	F5416	Petrol tank (3 gallons)	-	A	A
13	F4235	Styling strip (left, front)	-	A	A
14	F4127	Styling unit (left)	-	A	A
15	F4236	Styling strip (left, rear)	-	A	A
16	F3915	Knee grip plate (left)	-	A	A
17	S25-13 ⁶⁰⁻⁴²⁴⁸	Plain washer	-	A	A
18	T361	Knee grip plate bolt ($\frac{1}{4}$ in. U.H.)	-	A	A
19	F1606	Knee grip (left)	-	A	A
20	F4237	Styling strip (right, front)	-	A	A
21	F4128	Styling unit (right)	-	A	A
22	F4238	Styling strip (right, rear)	-	A	A
23	F3916	Knee grip plate (right)	-	A	A
24	F1605	Knee grip (right)	-	A	A
25	F5564	Centre styling strip	-	A	A
26	F3220 ⁸³⁻³²⁷⁵	FILLER CAP	1	1	1
27	F4048	Joint washer	1	1	1
28	F4971 ⁸³⁻²⁸⁰¹	Petrol tap (left)...	1	1	1
29	F4972 ⁸³⁻²⁸⁰⁰	Petrol tap with reserve tube	1	1	1
30	F1511	Fibre washer	2	2	2
31	F5228	Rubber washer	2	2	2
32	F5229	Spigot rubber	2	2	2
33	F3814	Cup	3	3	3
34	F1808	Bolt ($1\frac{3}{16}$ in. U.H.)	2	2	2
35	F5336	Double spigot rubber	1	1	1
36	F967	Rubber washer	1	1	1
37	F5337	Bolt ($1\frac{1}{32}$ in. U.H.)	1	1	1
38	F3917	Parcel grid	1	1	1
39	F2936	Screw	1	1	1
40	F4384	Rubber blanking plug	A	A	A

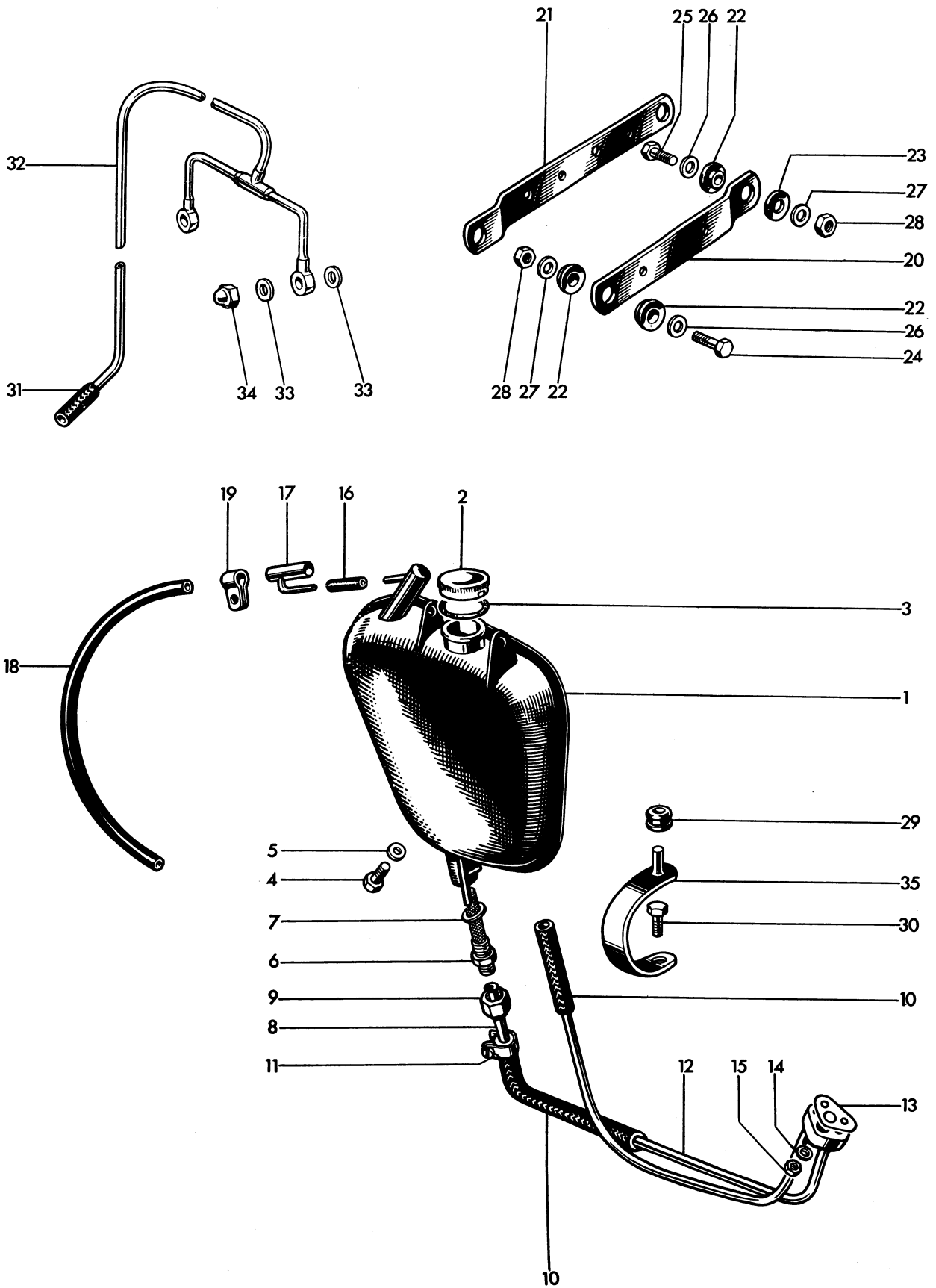

Fig. 23. OIL TANK

Ref. No.	Part No.	DESCRIPTION	QUANTITY		
OIL TANK					
			6T	TR6	T120
1	F6308	Oil tank ...	1	1	1
2	F321682-5155	FILLER CAP	1	1	1
3	F4047	Joint washer	1	1	1
4	F5343	Drain plug	1	1	1
5	PT104B51-3988	Fibre washer	1	1	1
6	F3179	Oil tank filter	1	1	1
7	F1713	Fibre washer	1	1	1
8	F3655	Upper feed pipe	1	1	1
9	F3182	Union nut	1	1	1
10	E4594	Flexible connector	2	2	2
11	E547370-6948	Clip	4	4	4
12	E459070-6930	Oil pipes and junction block .71-7.76	1	1	1
13	E376371-3754	Joint washer	1	1	1
14	E3446	Plain washer	1	1	1
15	E1310	Nut	1	1	1
16	E5374	Vent pipe	1	1	1
17	E5370	"T" piece	1	1	1
18	E5376	Extension pipe	1	1	1
19	F3098	Clip	2	2	2
20	F5949	Front strap	1	-	-
21	F5358	Rear Strap	1	-	-
20	F5328	Front strap	-	1	1
21	F5329	Rear strap	-	1	1
22	F5247	Spigot rubber	6	6	6
23	F5248	Rubber washer	2	2	2
24	F5330	Bolt ($\frac{3}{8}$ in. U.H.)	2	4	4
25	F5331	Bolt ($\frac{3}{8}$ in. U.H.)	2	-	-
26	S25-260-4246	Plain washer ($\frac{3}{8}$ in.)	4	4	4
27	S25-360-4247	Plain washer ($\frac{5}{16}$ in.)	4	4	4
28	T224	Nut	4	4	4
29	F6039	Grommet	1	1	1
30	F929	Bolt ($\frac{1}{2}$ in. U.H.)	1	1	1
31	E3383	Rubber connector	1	1	1
32	E415970-7574	Rocker oil feed pipe	1	1	1
33	E1335	Copper washer	4	4	4
34	E1435	Domed nut	2	2	2
35	F6147	Bracket	1	1	1

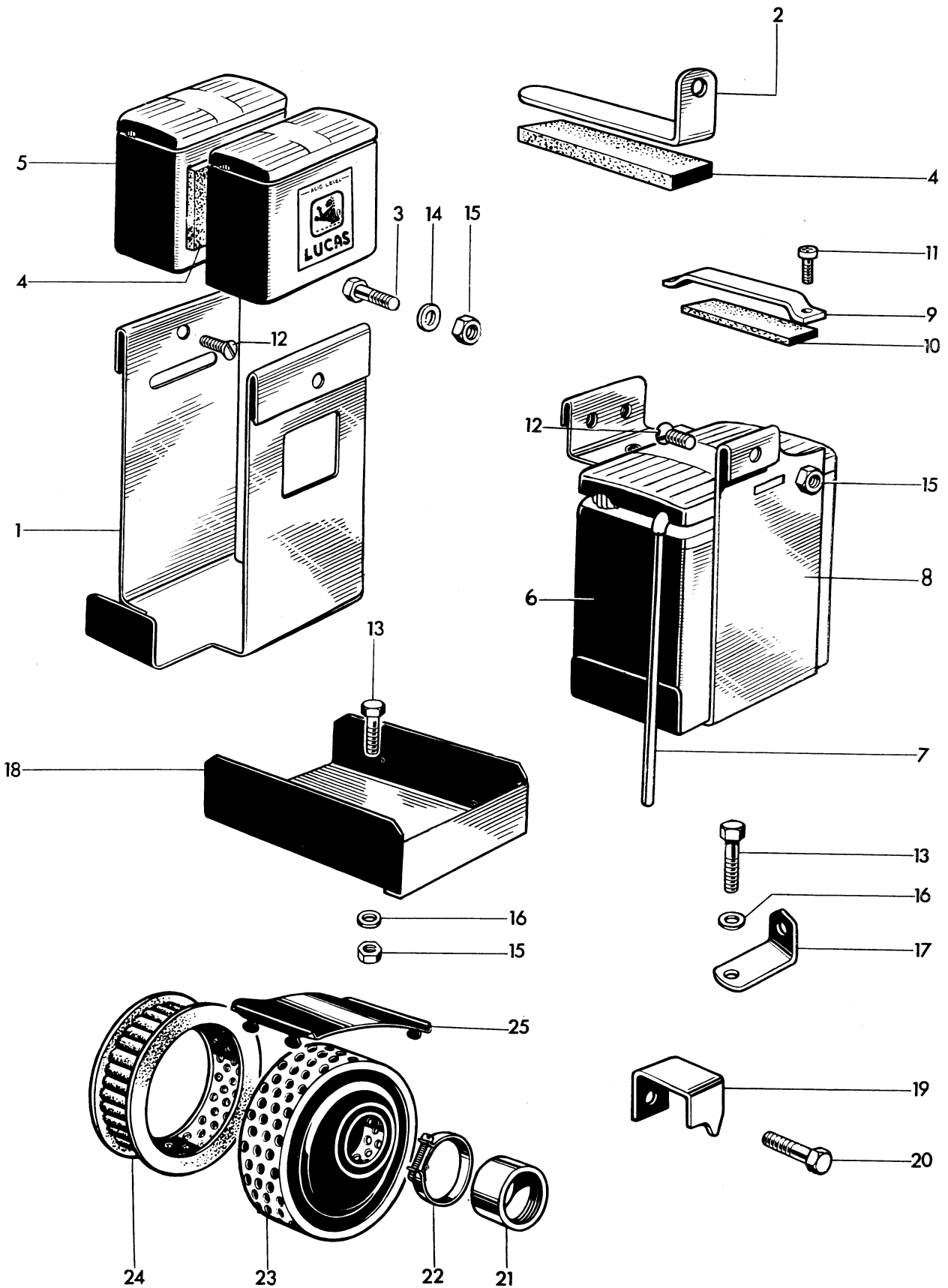

Fig. 24. BATTERY CARRIER AND AIR FILTER

BATTERY CARRIER AND AIR FILTER

			6T	TR6	T120
1	F5948	Battery carrier	1	-	-
2	F6129	Retainer strap	1	-	-
3	F1369	Bolt ($\frac{5}{8}$ in. U.H.)	1	-	-
4	F3470	Rubber pad	3	-	-
5	MKZ9E <i>Disc</i>	Battery	2	-	-
6	MLZ9E <i>Disc</i>	Battery c/w lid	-	1	1
7	F4814	Plastic vent pipe	2	1	1
8	F5333	Battery carrier	-	1	1
9	F4661	Top strap	-	1	1
10	F4662	Packing rubber	-	1	1
11	E3200	Screw ($\frac{11}{16}$ in. U.H.)	-	1	1
12	E3728	Screw ($\frac{15}{32}$ in. U.H.)	2	1	1
13	DS57 <i>82-9019</i>	Bolt ($\frac{7}{16}$ in. U.H.)	3	3	3
14	S25-1 <i>60-4245</i>	Plain washer	2	1	1
15	F879	Nut	6	5	5
16	S25-13 <i>60-4248</i>	Plain washer	3	2	2
17	F4283	Rectifier bracket	1	1	1
18	F5665	Tool tray	1	1	1
19	F5414	Inflator bracket	1	1	1
20	F1369	Bolt ($\frac{5}{8}$ in. U.H.)	1	1	1
21	F4576	Adaptor sleeve	1	-	-
22	F5625 <i>60-0707</i>	Clip	1	-	-
23	F5334 <i>82-6433</i>	AIR FILTER	1	-	-
24	F4811 <i>82-6866</i>	Filter element (felt)	1	-	-
21	F5958	Adaptor sleeve	-	1	-
22	F6074	Clip	-	1	-
23	F5956 <i>82-6432</i>	AIR FILTER	-	1	-
24	F5764 <i>82-6866</i>	Filter element (coarse felt)	-	1	-
25	F4964	Water deflector	-	1	-

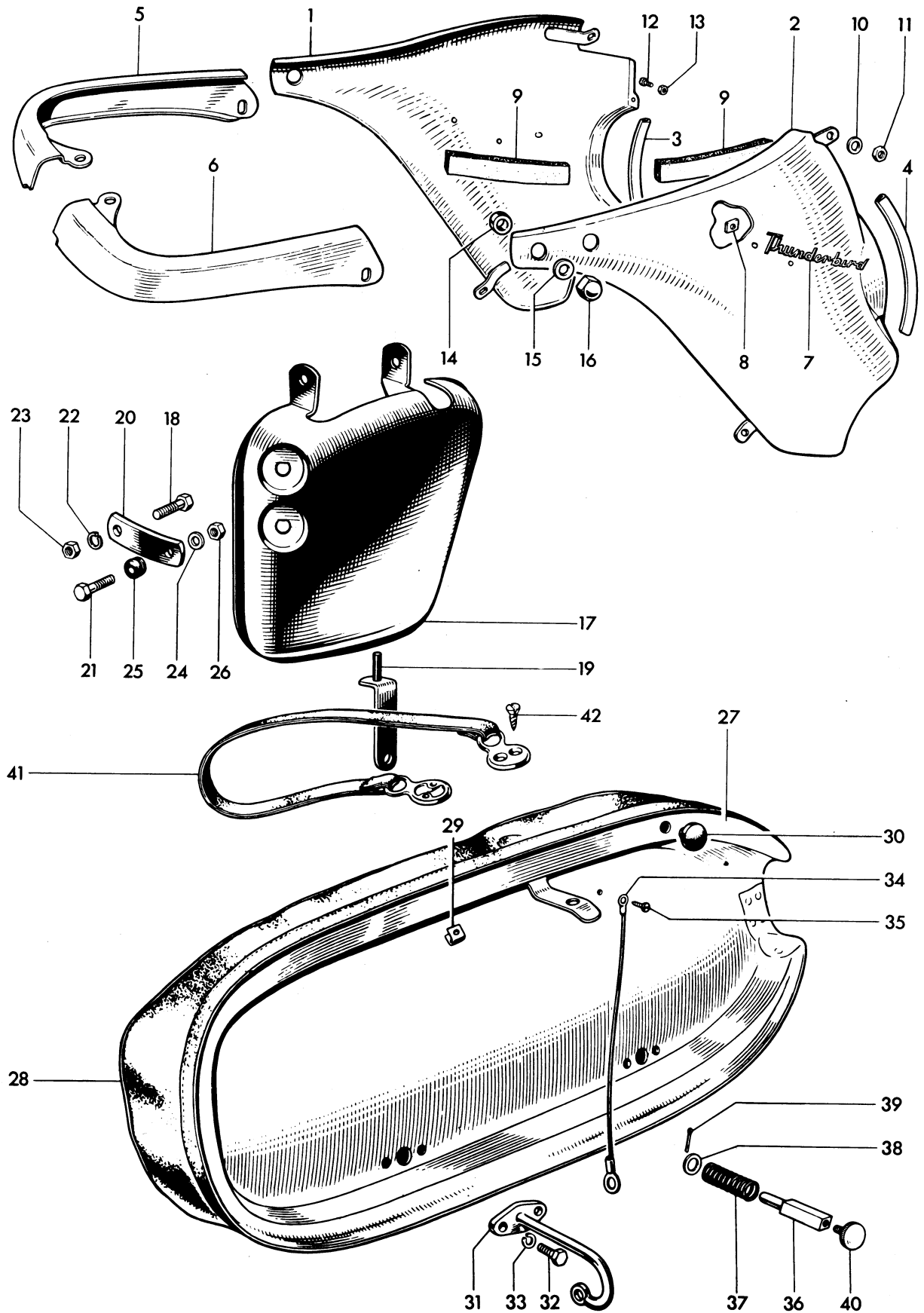

Fig. 25. PANELS AND TWINSEAT

Ref. No.	Part No.	DESCRIPTION	QUANTITY		
PANELS AND TWINSEAT					
1	F5319	Left panel	6T	TR6	T120
2	F5320	Right panel	1	-	-
3	F6104	Left beading	1	-	-
4	F6105	Right beading	1	-	-
5	F5323	Left valance	1	-	-
6	F5324	Right valance	1	-	-
7	F6195 82-6946	Motif "Thunderbird"	2	-	-
8	F4317	Spire nut	4	-	-
9	F5538	Rubber pad	2	-	-
10	S25-2 60-4246	Plain washer	2	-	-
11	S1-52 60-4261	Nut	2	-	-
12	F4715	Screw ($\frac{1}{2}$ in. U.H.)	2	-	-
13	F4717	Self locking nut	2	-	-
14	F2694	Distance piece	3	-	-
15	GS308 70-8770	Plain washer	4	-	-
16	E4329 70-1435	Domed nut	4	-	-
17	F5394	Switch panel	-	1	1
18	F1369	Bolt ($\frac{3}{8}$ in. U.H.)	-	1	1
19	F5939	Fixing bracket	-	1	1
20	F5923	Link	-	1	1
21	F1756	Bolt ($\frac{3}{4}$ in. U.H.)	-	1	1
22	S26-2 60-4250	Spring washer	-	2	2
23	F879	Nut	-	2	2
24	S25-43 70-8163	Washer	-	1	1
25	F5466	Grommet	-	2	2
26	E3290	Self locking nut	-	1	1
27	F5366 82-9502	TWINSEAT	1	1	1
28	F5418	Twinseat cover c/w clips	1	1	1
29	F4475	Clip		as required	
30	F4898	Rubber buffer	2	2	2
31	F4222	Hinge	2	2	2
32	DS57 82-9019	Bolt ($\frac{7}{16}$ in. U.H.)	4	4	4
33	S26-2 60-4250	Spring washer	4	4	4
34	D374	Check wire	1	1	1
35	F4483	Self tapping screw	1	1	1
36	F4226	Seat catch plunger	1	1	1
37	F4228	Spring	1	1	1
38	E1719A 71-3749	Plain washer	1	1	1
39	$\frac{3}{32}$ in. x $\frac{1}{2}$ in.	Split pin 60-2720	1	1	1
40	F4227 82-7560	Knob	1	1	1
41	F4361 82-7553	Safety strap		as required	
42	F4365	Self tapping screw	4	4	4

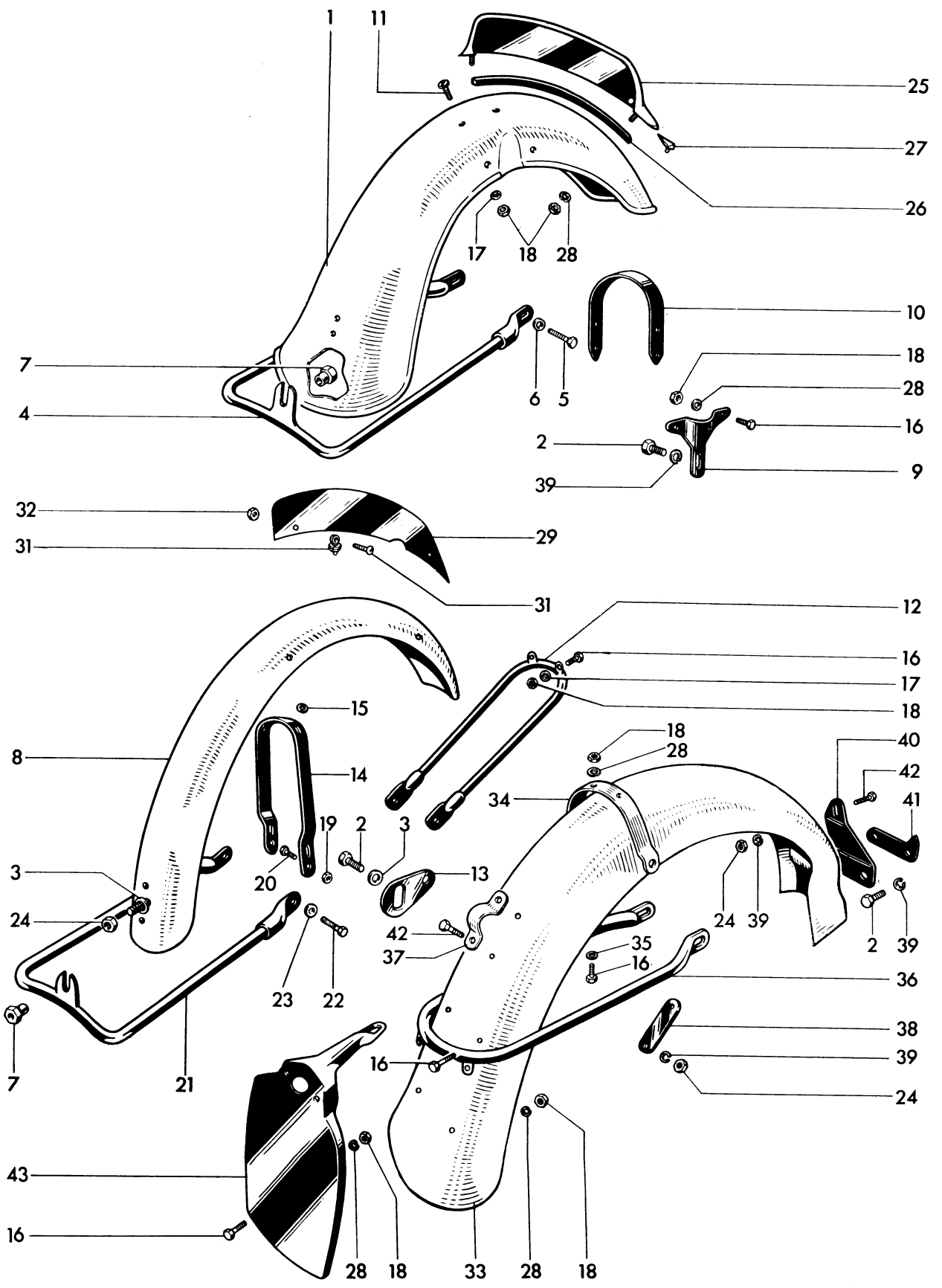

Fig. 26. MUDGUARDS

Ref. No.	Part No.	DESCRIPTION	QUANTITY		
MUDGUARDS					
			6T	TR6	T120
1	H1689	Front mudguard	1	-	-
2	F929	Bolt ($\frac{1}{2}$ in. U.H.)	4	4	4
3	F4299	Plain washer	4	5	5
4	H1100	Bottom stay	1	-	-
5	W62 37-1690	Bolt ($\frac{1}{8}$ in. U.H.)	2	-	-
6	S25-2 60-4246	Plain washer	2	-	-
7	NS362 99-3541	Spigot nut	1	1	1
8	H1675	Mudguard blade	-	1	1
9	H1540	Bracket	2	-	-
10	H1538	Mudguard bridge	2	-	-
11	F5001 70-6179	Bolt ($\frac{9}{16}$ in. U.H.)	5	-	-
12	H1681	Front stay	-	1	1
13	H1685	Bracket	-	2	2
14	H1683	Mudguard bridge	-	1	1
15	WE170 60-4263	Fibre washer	-	2	2
16	DS57 82-9019	Bolt ($\frac{7}{8}$ in. U.H.)	10	10	10
17	S25-1 60-4245	Plain washer	6	5	5
18	F879	Nut	17	10	10
19	T224	Nut	-	2	2
20	DS55 99-3516	Bolt ($\frac{5}{8}$ in. U.H.)	-	2	2
21	H1482	Bottom stay	-	1	1
22	H424	Bolt ($\frac{3}{8}$ in. U.H.)	-	2	2
23	S25-71 21-0025/071	Plain washer	-	2	2
24	S1-51 21-0001/051	Nut	3	4	4
25	F2698	Number plate	1	-	-
26	H251	Plastic beading	1	-	-
27	F4332	Packing piece	1	-	-
28	S26-2 60-4250	Spring washer	10	4	4
29	F2996	Number plate	-	1	1
30	H741	Clip assembly	-	2	2
31	H687	Screw ($\frac{3}{8}$ in. U.H.)	-	2	2
32	H745	Nut	-	2	2
33	F5953	Mudguard blade	1	-	-
33	F5984	Mudguard blade	-	1	1
34	F4860	Mudguard bridge	1	1	1
35	F4299	Plain washer	2	2	2
36	F5424	Lifting handle	1	1	1
37	F5994	Clip	1	1	1
38	F6031	Backing plate	1	1	1
39	S26-3 60-4260	Spring washer	7	5	5
40	F5369	Bracket	1	1	1
41	F5415	Inflator bracket	1	1	1
42	H590	Bolt ($\frac{9}{16}$ in. U.H.)	3	3	3
43	F5924	Number plate	1	1	1

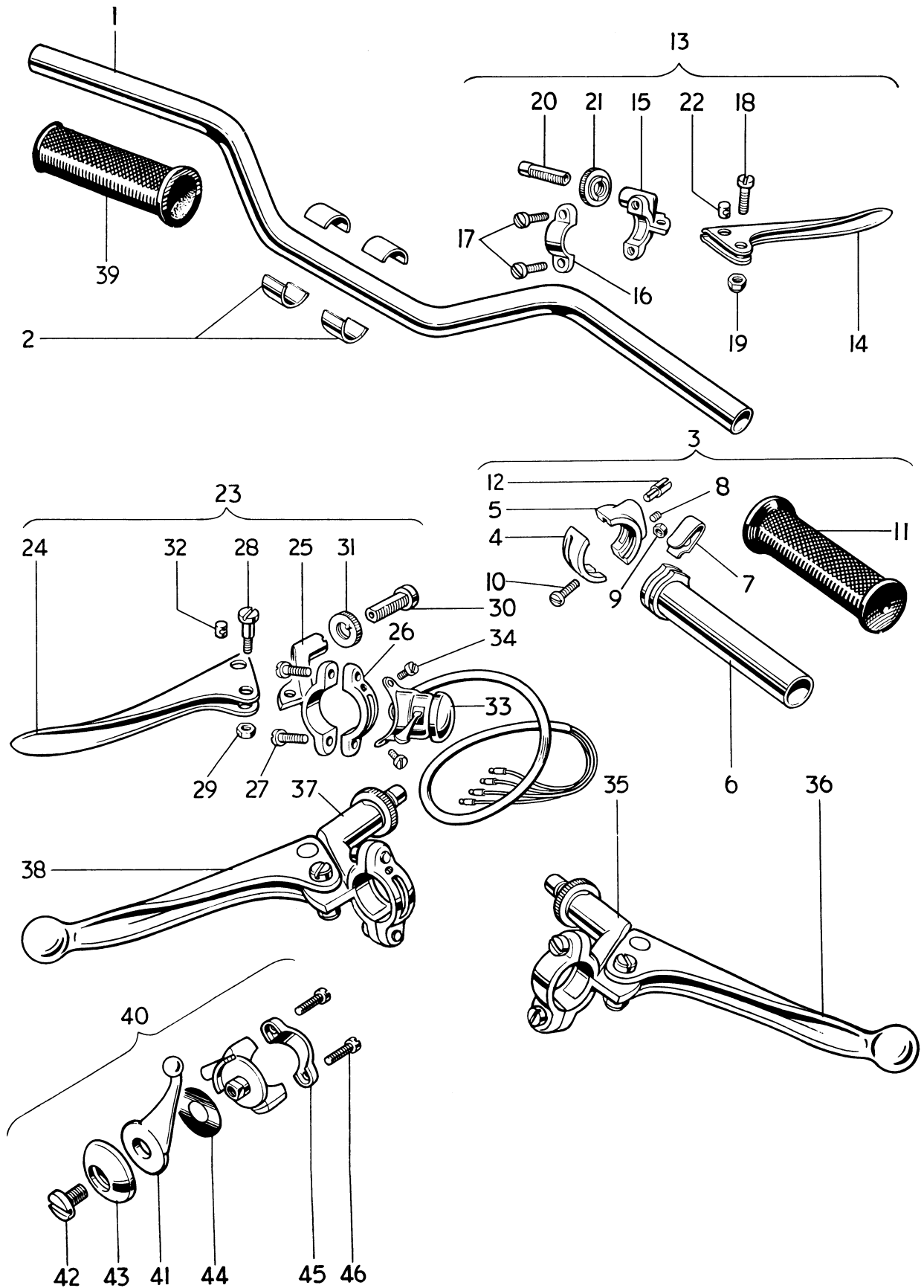

Fig. 27. HANDLEBARS AND CONTROL LEVERS

HANDLEBARS AND CONTROL LEVERS

			6T	TR6	T120
1	H1484 97-4552	Handlebar	1	1	1
2	H1425	Packing piece	4	4	4
3	16/417	TWISTGRIP	1	1	1
4	16/328	Body top half	1	1	1
5	16/329	Body bottom half	1	1	1
6	16/091	Rotor	1	1	1
7	16/008	Friction spring	1	1	1
8	16/009	Friction spring screw	1	1	1
9	16/010	Locknut	1	1	1
10	11/013	Screw	2	2	2
11	16/070	Grip	1	1	1
12	16/011	Cable stop	1	1	1
13	18/995	FRONT BRAKE LEVER ASSEMBLY	1	-	1
14	18/535	Brake lever	1	-	1
15	18/912	Brake lever bracket	1	1	1
16	12/040	Clamp	1	1	1
17	11/014	Screw	2	2	2
18	18/087	Fulcrum screw	1	1	1
19	18/053	Self locking nut	1	1	1
20	18/838	Cable adjuster	1	1	1
21	18/839	Thumb nut	1	1	1
22	18/880	Barrel nipple	1	1	1
23	18/996	CLUTCH LEVER ASSEMBLY	1	-	1
24	18/528	Clutch lever	1	-	1
25	18/913	Clutch lever bracket	1	1	1
26	18/910	Clamp (H668A)	1	1	1
27	61/004	Screw	2	2	2
28	18/087	Fulcrum screw	1	1	1
29	18/053	Self locking nut	1	1	1
30	18/838	Cable adjuster	1	1	1
31	18/839	Thumb nut	1	1	1
32	18/880	Barrel nipple	1	1	1
33	31563	Horn push and dip switch	1	1	1
34	H689	Screw (1/4 in. U.H.)	2	2	2
35	18/935	FRONT BRAKE LEVER ASSEMBLY (Ball-end)	-	1	-
36	18/754	Brake lever (Ball-end)	-	1	-
37	18/993	CLUTCH LEVER ASSEMBLY (Ball-end)	-	1	-
38	18/752	Clutch lever (Ball-end)	-	1	-
39	16/069	Handlebar grip	1	1	1
40	12/608	AIR LEVER	1	1	-
41	12/556	Lever	1	1	-
42	12/607	Bolt	1	1	-
43	12/606	Cap	1	1	-
44	12/033	Spring washer	1	1	-
45	12/040	Clamp	1	1	-
46	11/014	Screw	2	2	-

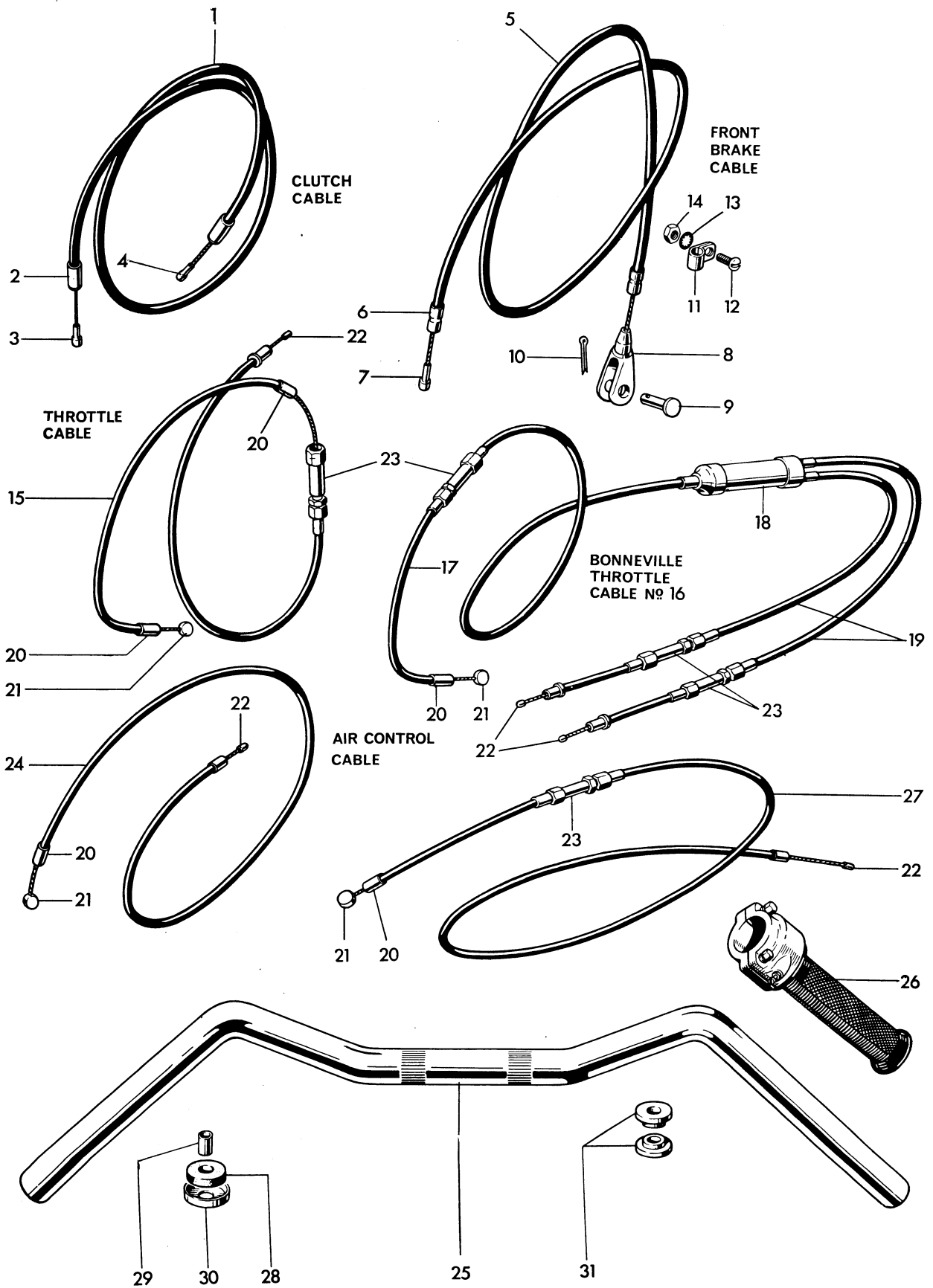

Fig. 28. CONTROL CABLES AND AMERICAN HANDLEBARS

CONTROL CABLES AND AMERICAN HANDLEBARS

										6T	TR6	T120
1	D466	CLUTCH CABLE	1	1	1
2	D103	Ferrule	2	2	2
3	D368	Nipple	1	1	1
4	DS73 99-3510	Nipple	1	1	1
5	D416 60-0474	FRONT BRAKE CABLE	1	1	1
6	D103	Ferrule	2	2	2
7	D368	Nipple	1	1	1
8	W593	Fork end	1	1	1
9	WF32 60-4252	Pivot pin...	1	1	1
10	$\frac{1}{8}$ in. x $\frac{5}{8}$ in.	Split pin	1	1	1
11	H1171	Clip	1	-	-
12	F4715	Screw ($\frac{13}{32}$ in. U.H.)	1	-	-
13	GS299 60-4256	Serrated washer	1	-	-
14	H745	Nut	1	-	-
15	D495	THROTTLE CABLE	1	-	-
15	D519	THROTTLE CABLE	-	1	-
16	D499	THROTTLE CABLE	-	-	1
17	D500	Twistgrip cable	-	-	1
18	244/104	Junction block	-	-	1
19	D423	Carburetter cable	-	-	2
20	D101	Ferrule	3	3	10
21	D83	Nipple	1	1	1
22	NS191	Nipple	1	1	5
23	D104	Adjuster	1	1	3
24	D435	Air control cable	1	-	-
24	D507	Air control cable	-	1	-
25	H1694	American handlebar	1	-	-
25	H1511 97-4252	American handlebar	-	1	1
5	D417 60-0474	Front brake cable	1	1	1
16	D515	Throttle cable	-	-	1
26	313/6	Twin rotor twistgrip	-	-	1
27	D528	Throttle cable	-	-	2
28	H1580	Steady rubber	2	2	2
29	H1581	Distance piece	2	2	2
30	F3814	Cup	2	2	2
31	H1616	Solid bush (for handlebar-mounted windscreen)	4	4	4

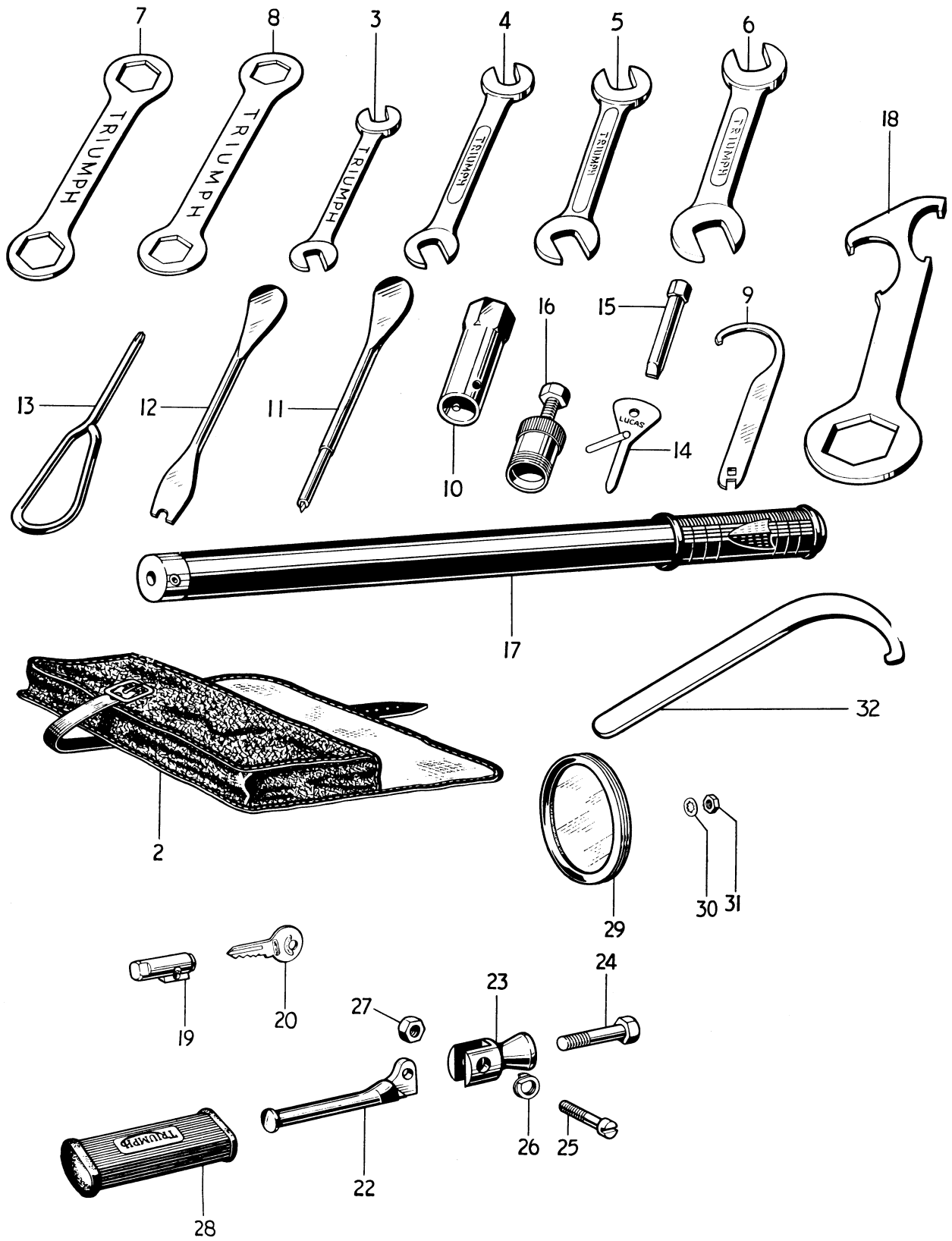

Fig. 29. TOOLKIT, FRAME LOCK, PILLION FOOTRESTS AND LICENCE HOLDER

**TOOLKIT, FRAME LOCK, PILLION FOOTRESTS AND
LICENCE HOLDER**

									6T	TR6	T120
1	D365	60-0769	TOOLKIT COMPLETE	1	1	1
2	WA58	60-0291	Tool roll	1	1	1
3	D360		Open spanner, $\frac{1}{8} \times \frac{5}{32}$ in. Whit.	1	1	1
4	D361		Open spanner, $\frac{3}{16} \times \frac{1}{4}$ in. Whit.	1	1	1
5	NA55	99-3539	Open spanner, $\frac{1}{4} \times \frac{5}{16}$ in. Whit.	1	1	1
6	DA16	99-3511	Open spanner, $\frac{3}{8} \times \frac{7}{16}$ in. Whit.	1	1	1
7	PA57	99-3548	Ring spanner, $\frac{1}{2} \times \frac{9}{16}$ in. Whit.	1	1	1
8	D311		Ring spanner, $\frac{5}{8} \times \frac{1}{16}$ in. Whit.	1	1	1
9	D362		"C" spanner and tappet key	1	1	1
10	D87	99-3513	Plug spanner	1	1	1
11	D363	60-0767	Tyre lever and screwdriver	1	1	1
12	D364		Tyre lever and clutch key	1	1	1
13	D336		Phillips No. 3 screwdriver	1	1	1
14	400935		Screwdriver	1	1	1
15	D496		Screwdriver for chain tensioner	1	1	1
16	DA50/1	60-0662	Clutch hub extractor	A	A	A
17	D296		Tyre inflator	1	1	1
18	D220		Fork spanner (for cap nut)	A	A	A
19	D402/3		FRAME LOCK c/w KEYS	1	1	1
20	D403		Key (state number)	1	1	1
21	F5552	82-9369	PILLION FOOTREST	2	2	2
22	F1694		Pedal	2	2	2
23	F2268		Hanger	2	2	2
24	F5535		Bolt ($\frac{1}{16}$ in. U.H.)	2	2	2
25	F2271		Pivot bolt	2	2	2
26	F2277		Thackeray (spring) washer	2	2	2
27	S1-51	21-0001/051	Nut	2	2	2
28	F1695		Pedal rubber	2	2	2
29	D261	60-2599	Licence holder	1	1	1
30	E1612		Serrated washer	1	-	-
31	F879		Nut	1	-	-
32	D527		Fork spanner (for sleeve nut)...	A	A	A

**CARBURETTER COMPLETE
REF. N°1**

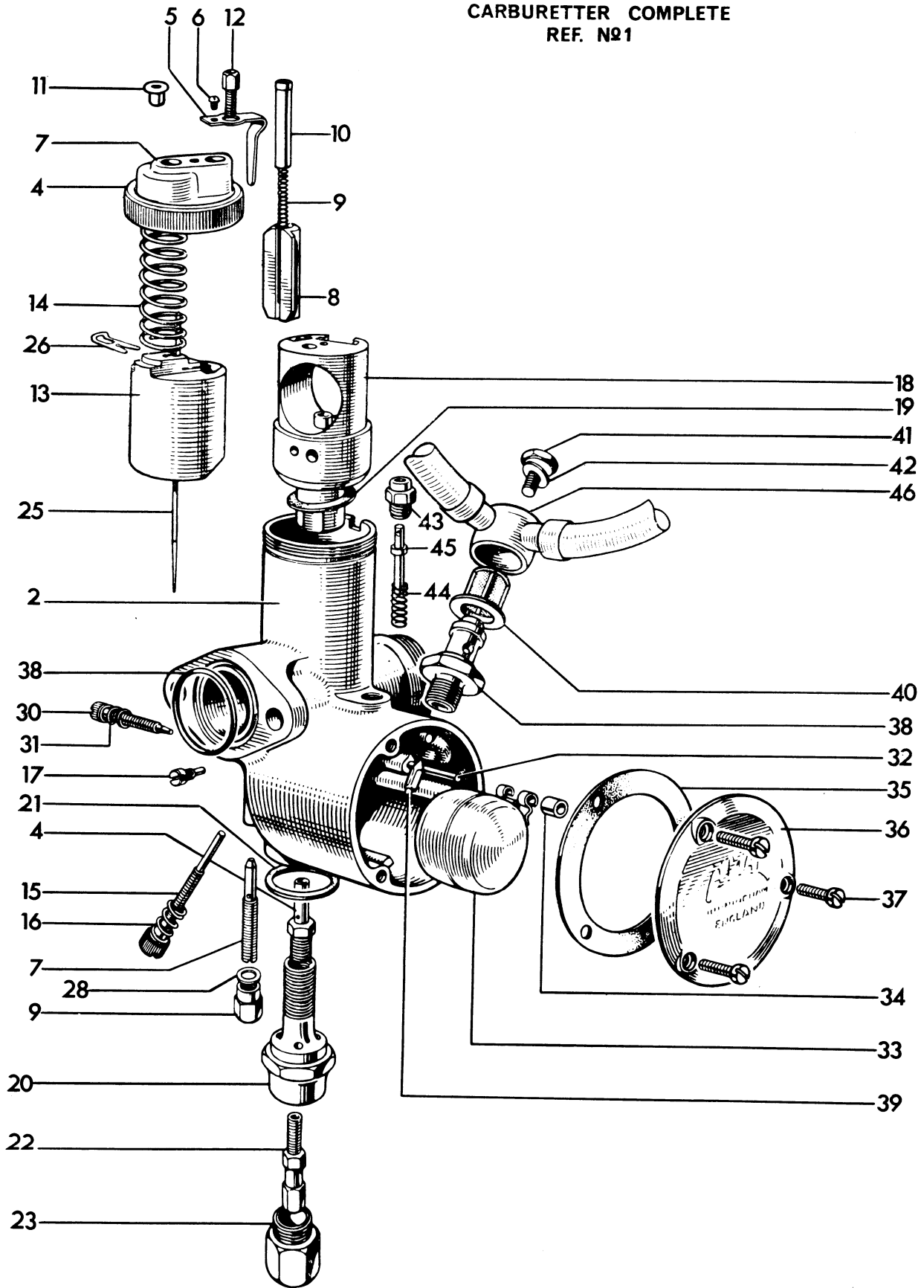

Fig. 30. AMAL CARBURETTER, 6T

Ref. No.	Part No.	DESCRIPTION	QUANTITY
AMAL CARBURETTER 6T			
1	376/303	CARBURETTER	6T
2	376/003	Mixing chamber, 1 $\frac{1}{8}$ in. choke	1
3	244/1048	"O" ring seal	1
4	376/065	Mixing chamber cap	1
5	29/307	Spring	1
6	4/241	Screw	1
7	376/107	Mixing chamber top	1
8	376/062	Air valve	1
9	4/046	Spring	1
10	6/047	Air valve guide	1
11	6/132A	Throttle cable ferrule	1
12	4/035	Air cable adaptor	1
13	376/060	Throttle valve (state cutaway)	1
14	376/061	Throttle return spring	1
15	376/068	Throttle stop screw	1
16	376/069	Stop screw spring	1
17	376/070	Peg screw	1
18	376/057	Jet block (1 $\frac{1}{8}$ in. choke)	1
19	376/067	Joint washer	1
20	376/073	Jet holder	1
21	376/074	Fibre washer	1
22	376/100	Main jet (state size)	1
23	376/075	Cover nut	1
24	376/072	Needle jet (0.106)	1
25	376/063	Needle (Type C)	1
26	4/230	Needle clip	1
27	376/076	Pilot jet (state size)	1
28	116/017	Fibre washer	1
29	376/095	Cover nut	1
30	332/017	Air adjusting screw	1
31	4/148	Spring	1
32	376/085	Float spindle	1
33	376/083	Float	1
34	376/094	Bush	1
35	376/078	Joint washer	1
36	376/077	Cover	1
37	376/079	Screw	3
38	376/088	Needle seating	1
39	376/089	Needle	1
40	376/093	Filter	1
41	376/091	Bolt	1
42	376/092	Fibre washer	1
43	376/086	Tickler	1
44	376/087	Tickler spring	1
45	343/011	Tickler body	1
46	F5339	Petrol pipe	1

CARBURETTER COMPLETE
REFERENCE N°1

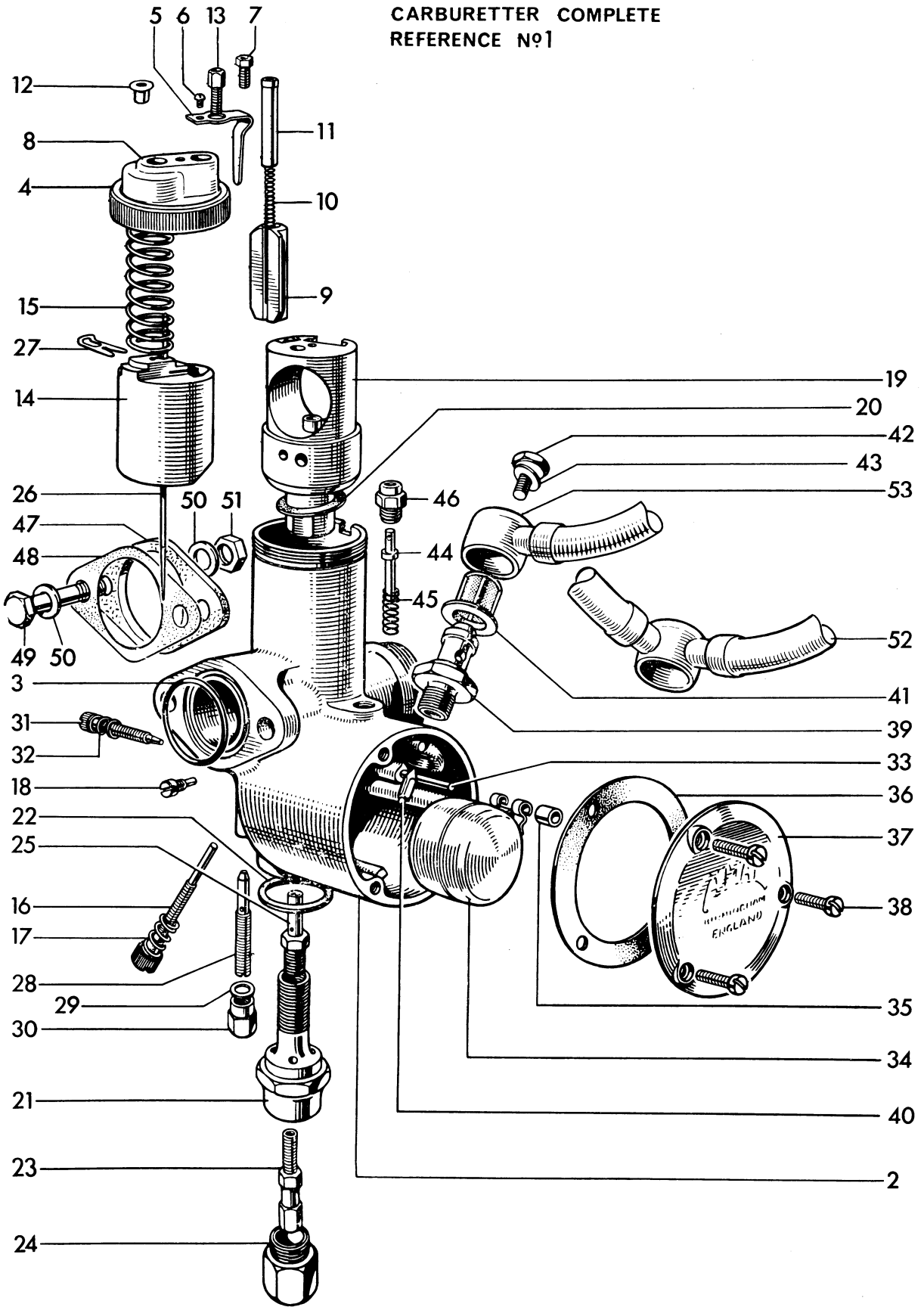

Fig. 31. AMAL CARBURETTER, TR6 AND T120

Ref. No.	Part No.	DESCRIPTION	TR6	T120
AMAL CARBURETTER, TR6 & T120				
1	389/97	CARBURETTER	1	-
1	389/203	CARBURETTER	-	2
2	389/002	Mixing chamber (1 $\frac{1}{8}$ in. choke)	1	2
3	244/1048	"O" ring seal	1	2
4	389/065	Mixing chamber cap	1	2
5	29/307	Spring	1	2
6	4/241	Screw	1	2
7	4/137A	Plug screw	-	2
8	389/107	Mixing chamber top	1	2
9	389/062	Air valve	1	-
10	4/046	Spring	1	-
11	29/057	Air valve guide	1	-
12	6/132A	Throttle cable ferrule	1	2
13	4/035	Air cable adjuster	1	-
14	389/060	Throttle valve (state cutaway)	1	2
15	389/061	Throttle return spring	1	2
16	376/068	Throttle stop screw	1	2
17	376/069	Stop screw spring	1	2
18	376/070	Peg screw	1	2
19	389/056	Jet block (1 $\frac{1}{8}$ in. choke)	1	2
20	376/067	Joint washer	1	2
21	376/073	Jet holder	1	2
22	376/074	Fibre washer	1	2
23	376/100	Main jet (state size)	1	2
24	376/075	Cover nut	1	2
25	376/072	Needle jet (0.106)... ..	1	2
26	389/063	Needle (Type D)	1	2
27	4/230	Needle clip	1	2
28	376/076	Pilot jet (state size)	1	2
29	116/162	Fibre washer	1	2
30	376/095	Cover nut	1	2
31	332/017	Air adjusting screw	1	2
32	4/148	Spring	1	2
33	376/085	Float spindle	1	2
34	376/083	Float	1	2
35	376/094	Bush	1	2
36	376/078	Joint washer	1	2
37	376/077	Cover	1	2
38	376/079	Screw	3	-
38	376/151	Screw	-	6
39	376/088	Needle seating	1	2
40	376/089	Needle	1	2
41	376/093	Filter	1	2
42	376/091	Bolt	1	2
43	376/092	Fibre washer	1	2
44	376/086	Tickler	1	2
45	376/087	Tickler spring	1	2
46	343/011	Tickler body	1	2
47	E2968 70-4918	Insulating block	-	2
48	NA43A 71-1416	Joint washer	-	2
49	F2603	Bolt (1 $\frac{5}{8}$ in. U.H.)	-	4
50	S25-3 60-4247	Plain washer	-	4
51	T224	Nut	1	-
52	F5339	Petrol pipe	-	1
53	F5462	Petrol pipe	-	1

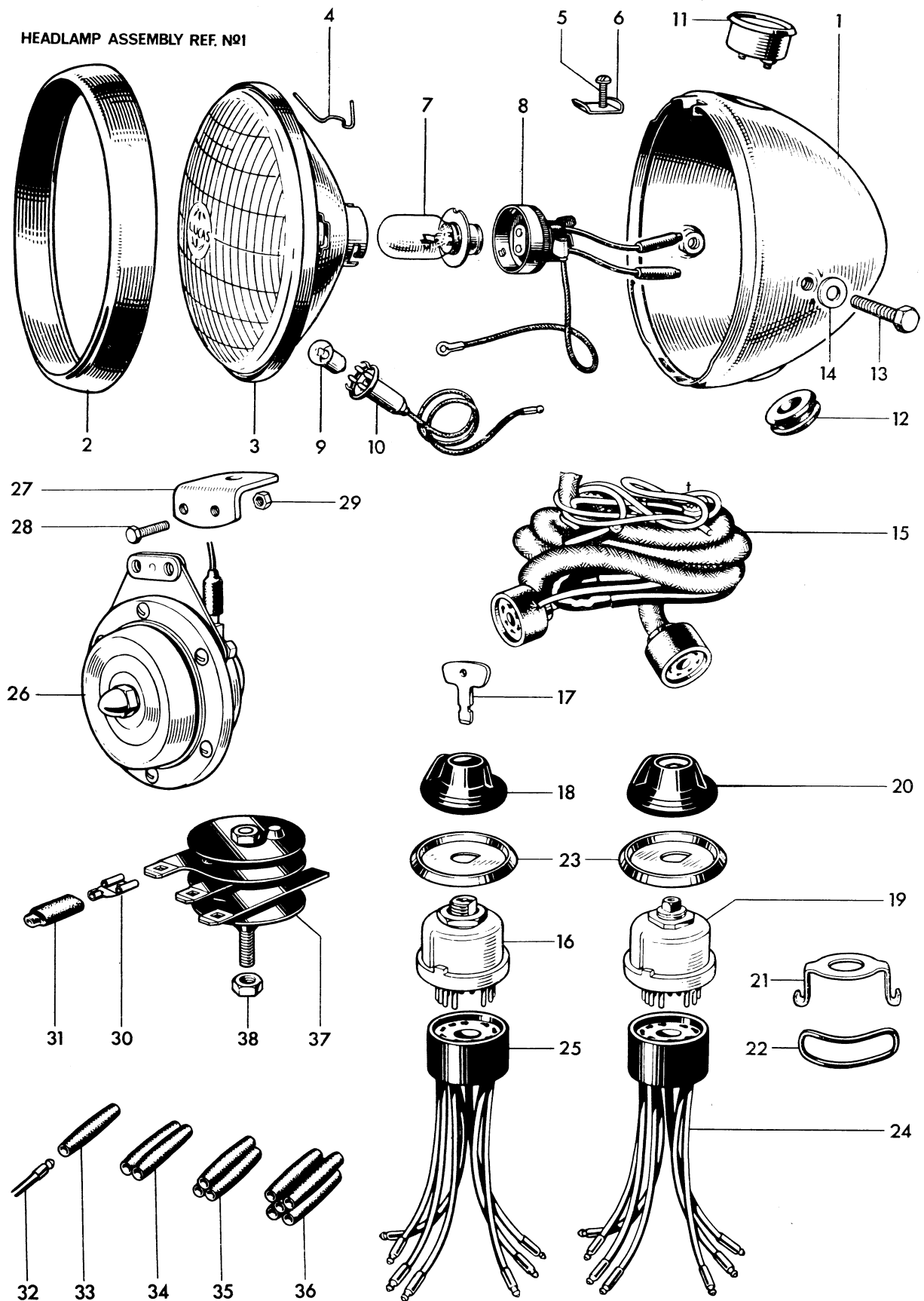

Fig. 32. HEADLAMP, WIRING HARNESS, HORN AND RECTIFIER

HEADLAMP, WIRING HARNESS, HORN AND RECTIFIER

1	58934 59579	HEADLAMP COMPLETE	-	1	1
2	553248	Rim	-	1	1
3	516798	Light unit	-	1	1
4	504665	Fixing wire...	-	6	6
5	144921	Screw	-	1	1
6	534296	Plate	-	1	1
7	312	Bulb (30/24 W. Vert dip. Pre-focus)	-	1	1
8	554602	Main bulbholder	-	1	1
9	988 951	Bulb (3W. M.C.C.)	-	1	1
10	554710	Pilot bulbholder	-	1	1
11	36296 36403	Ammeter, type 2AR	-	1	1
12	862217	Grommet	-	1	1
13	112201	Bolt	-	2	2
14	137499 Disc	Plain washer	-	2	2
15	54933182 Disc	Wiring harness	-	1	1
16	34427	IGNITION SWITCH COMPLETE WITH KEY, type 88SA	-	1	1
17	54336176	Ignition key	-	1	1
18	54336178	Ignition switch cover	-	1	1
19	34289	Lighting switch, type 88SA	-	1	1
20	54330934	Knob c/w screw	-	1	1
21	F5983	Bracket	-	2	2
22	F5988	Rubber band	-	2	2
23	54330576	Switch bezel plate	-	2	2
24	54930007	Replacement harness socket (Lighting)	-	1	1
25	54930008	Replacement harness socket (ignition)	-	1	1
26	70163	Horn, type 8H	-	1	1
27	F5086	Bracket	-	1	1
28	T1076	Screw ($\frac{3}{8}$ in. U.H.)	-	2	2
29	F3799	Nut	-	2	2
30	54942078 54960661	Lucar connector	5	5	5
31	54190042	Insulating cover...	5	5	5
32	900269	Snap connector terminal		as required	
33	900288	Single snap connector		as required	
34	850641	Double snap connector		as required	
35	850844	Triple snap connector		as required	
36	850832	Quintuple snap connector		as required	
37	49072	Rectifier, type 2DS 506	1	1	1
38	F5338	Nut (156 596)	1	1	1

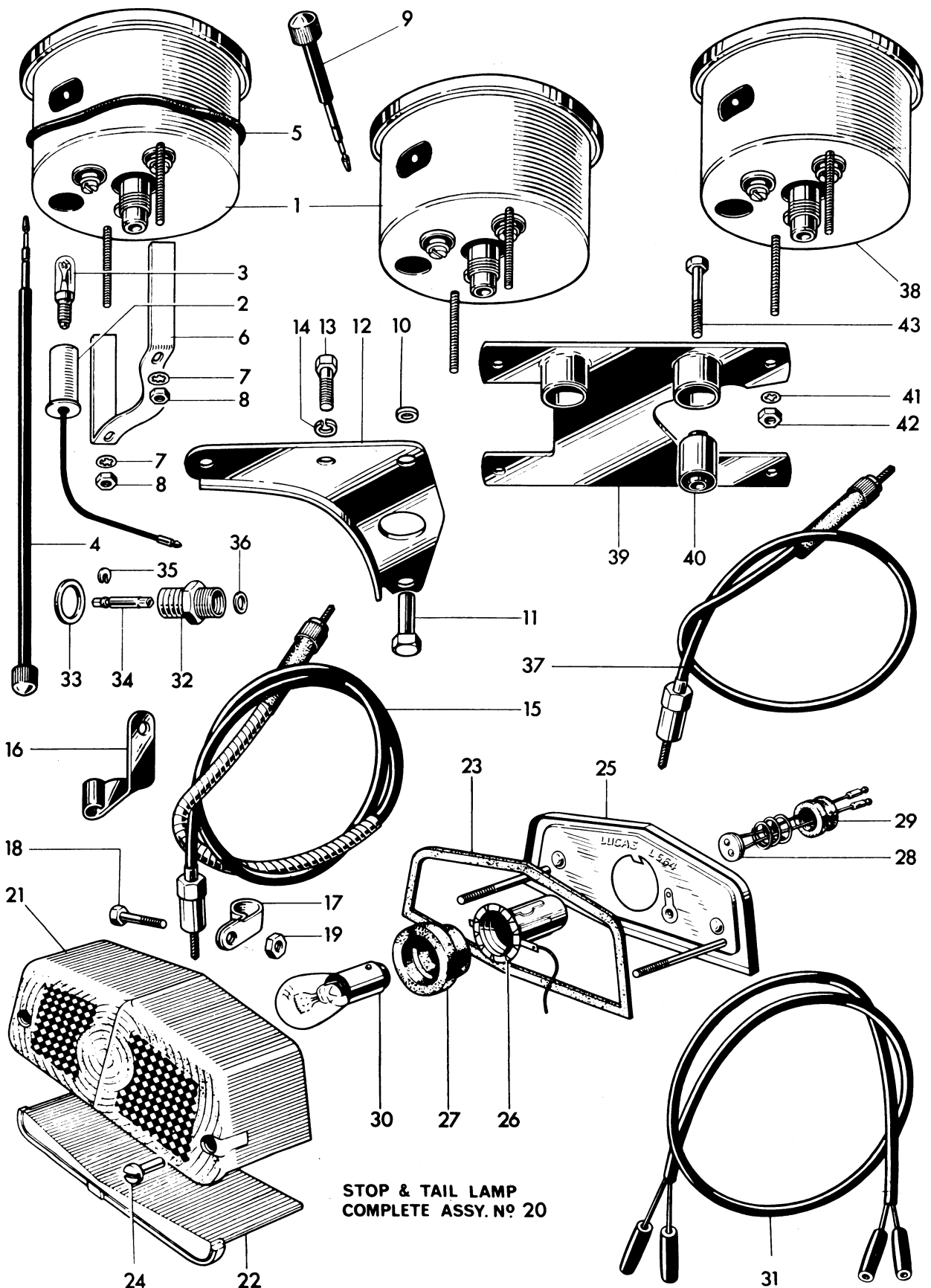

Fig. 33. SPEEDOMETER TACHOMETER AND TAIL LAMP

Ref. No.	Part No.	DESCRIPTION	QUANTITY	6T	TR6	T120
SPEEDOMETER, TACHOMETER AND TAIL LAMP						
1	SSM5002/00	Speedometer head MPH	1	-	-	
1	SSM5002/01	Speedometer head KPH	A	-	-	
1	SSM5001/00	Speedometer head MPH	-	1	-	
1	SSM5001/01	Speedometer head KPH	-	A	A	
2	554734	Bulb holder	1	1	1	
3	987	Bulb, 3.W. M.E.S.	1	-	-	
3	990	Bulb, 3.W. M.E.S.	-	1	1	
4	41-118-127-72	Trip control	1	-	-	
5	31-753-778	Rubber ring	1	-	-	
6	31-674-188-01	Fixing strap	1	-	-	
7	30-283-014-11	Washer	2	-	-	
8	30-277-023-11	Nut	2	-	-	
9	41-148-203-10	Trip control	-	1	1	
10	H1702	Distance piece	-	2	2	
11	H1701	Sleeve nut	-	2	2	
12	H1668	Bracket	-	1	1	
13	DS57 92-9019	Bolt ($\frac{7}{16}$ in. U.H.)	-	2	2	
14	S26-2 60-4250	Spring washer	-	2	2	
15	D542 DF9106/01B	Speedometer cable (44 ins. long)	1	-	-	
15	D543 DF9106/01A	Speedometer cable (40 $\frac{1}{2}$ ins. long)	-	1	1	
16	H1698	Cable bracket	1	-	-	
17	F3098	Clip	1	1	1	
18	F1718	Bolt (1 $\frac{3}{16}$ in. U.H.)	1	1	1	
19	S1-51 21-000/051	Nut	1	1	1	
20	53454	STOP AND TAIL LAMP (type 564)	1	-	-	
20	53432 53454	STOP AND TAIL LAMP (type 564)	-	1	1	
21	573839 54576001	Lens...	1	1	1	
22	575200 Disc	Window	1	1	1	
23	575208 Disc	Lens seating gasket	1	1	1	
24	575219	Sleeve nut	2	2	2	
25	576002 Disc	Base assembly	1	1	1	
26	575209 Disc	Bulb holder	1	1	1	
27	575207	Grommet	1	1	1	
28	573828	Contact assembly	1	1	1	
29	573825	Grommet	1	1	1	
30	380	Bulb (6/21W. Offset pin)	1	-	-	
30	384	Bulb (6/18W. Offset pin)	-	1	1	
31	838604	Stop and tail lamp lead	1	1	1	
32	E4699 70-5667	Adaptor	-	1	1	
33	T1257	Fibre washer	-	1	1	
34	D493 99-0173	Spade	-	1	1	
35	D494	Circlip	-	1	1	
36	E4803	"O" ring	-	1	1	
37	D529	Tachometer cable (34 $\frac{1}{2}$ in. long)	-	1	1	
38	RSM 3001/02	Tachometer	-	1	1	
39	H1596 97-1946	MOUNTING BRACKET	-	1	1	
40	H1087	Metalastik bush	-	2	2	
41	30-282-014-11	Washer	-	4	4	
42	30-276-037-11	Nut	-	4	4	
43	H1086	Bolt (1 $\frac{3}{16}$ in. U.H.)	-	2	2	

Printed in England by

WARWICK PRINTING COMPANY LIMITED
WARWICK