

TRIUMPH

OWNER'S HANDBOOK

FOR

UNIT CONSTRUCTION
40 cub. in. (650 c.c.) TWIN

1970
MODELS

See Bookmarks

TRIUMPH ENGINEERING CO. LTD.
MERIDEN WORKS · ALLESLEY · COVENTRY · ENGLAND

TELEPHONE: MERIDEN 331

TELEGRAMS: "TRUSTY, COVENTRY"

REF. 99—0891

U.S.A. EDITION

INDEX

	<i>Page</i>
Air filter	29
Brakes	23
Brake adjustment	14
Carburetor	28
Chain adjustment	16
Cleaning your motorcycle	26
Controls	9
Electrical equipment	31
Front forks	19
General description	8
Guarantee arrangements	4
Lubrication	39
Oil changing	26
Rear suspension	20
Routine maintenance	37
Running-in	12
Spark plugs	25
Starting	11
Tires	22
Useful data	5-6-7
Valve adjustment	12
Wheels	21

ILLUSTRATION INDEX

<i>Fig.</i>		<i>Page</i>
1	Control layout	10
2	To adjust the valve operating mechanism	13
3	Showing brake adjusters	15
4	To adjust the primary chain	17
5	Rear suspension spring adjustment	20
6	Contact breaker, type 6CA	24
7	Gearbox drain and level plugs	27
8	Amal concentric carburetor	29
9	To secure the rectifier	33
10	Zener Diode	34
11	Wiring Diagram	35
12	Headlamp showing lighting switch, ammeter and warning lights	36
13	Lubrication points	39

INTRODUCTION

The Owner's Handbook includes all the information that the majority of owners will require. If you require more information for major repairs there is available a Workshop Manual but this is intended for those having basic mechanical knowledge and workshop facilities. To obtain the Workshop Manual order from your local Triumph dealer or distributor as we do not supply parts or service literature direct from the factory to individual customers.

Where specialised advice is required beyond the ability of the dealer, then you should write to your distributor who will act on our behalf. Unless the full engine number is quoted it is often difficult to identify the type of motorcycle and give a helpful reply. Any information which may have a bearing on the subject should be included, particularly details of any additions or alterations to the standard equipment

Where a guarantee claim is involved, consult your dealer or distributor who may be able to provide a replacement to enable your motorcycle to be used whilst the defective part is returned to his distributor. Guarantee claims in respect of proprietary components should be forwarded by your dealer to his distributor.

Eastern Distributors

Triumph Corporation,
Towson,
Baltimore, 4,
MD. 21204.

CABLES:

Triumph, Baltimore.
Telephone 301-252-1700

Western Distributors

Johnson Motors, Inc.,
P.O. Box 275
Duarte,
California,
91010

CABLES:

"JOMO". Duarte Calif.
Telephone 213-359-3221
213-681-0255



650 c.c. TRIUMPH TIGER 650 TR6R

USEFUL DATA

	TR6R	TR6C	T120R
MOTOR			
Bore and Stroke—mm.	71 x 82	71 x 82	71 x 82
Bore and Stroke—in.	2.795 x 3.23	2.795 x 3.23	2.795 x 3.23
Capacity—c.c. ...	649	649	649
Capacity—cub. in. ...	40	40	40
Compression Ratio ...	9.0 : 1	9.0 : 1	9.0 : 1
Power Output B.H.P. @			
r.p.m. ...	45* @ 6,500	45* @ 6,500	50* @ 6,500
Tappet Clearance, Inlet and Exhaust—in. (Cold)...	0.002, 0.004	0.002, 0.004	0.002, 0.004
Valve Timing	I.O. 34°	34°	34°
Checked @	I.C. 55°	55°	55°
0.020" Lift at	E.O. 55°	55°	55°
the tappet	E.C. 34°	34°	34°

*Straight through exhaust system.

	TR6R	TR6C	T120R
IGNITION—Timing (Before top center)			
Crankshaft position ...	38°	38°	38°
Contact Breaker Gap—in.		0.014"—0.016"	

SPARK PLUGS

Type	Champion N3, KLG, FE100 or FE220 (See Page 25)		
Point Gap	0.025 in.		

CAPACITIES

Fuel Tank	4 U.S. gals.	2½ U.S. gals.	4 U.S. gals.
Oil Tank	6 U.S. pints	6 U.S. pints	6 U.S. pints
Gearbox	500 c.c.	500 c.c.	500 c.c.
Primary Chaincase (Initial fill)	350 c.c.	350 c.c.	350 c.c.
Front Forks (each leg) ...	200 c.c.	200 c.c.	200 c.c.

	TR6R	TR6C	T120R
CARBURETOR			
Amal Type	930	930	930
Main Jet	230	230	220
Needle Jet107	.107	.106
Needle Type	STD	STD	STD
Needle Position	2	2	2
Throttle Valve	930/4	930/4	930/2½

SPROCKETS

Gearbox, Solo	19	18	19
Rear Wheel	46	46	46

CHAINS

Primary— $\frac{3}{8}$ in. pitch Duplex, links	84	84	84
Secondary— $\frac{5}{8}$ in. pitch x $\frac{3}{8}$ in. wide, links solo	104	104	104

	TR6R	TR6C	T120R
GEAR RATIOS			
4th Top	4.88	5.11	4.88
3rd Third	6.04	6.36	6.04
2nd Second	8.17	8.64	8.17
1st Bottom	11.81	12.51	11.81
Engine R.P.M. @ 10 m.p.h.	634	670	634

TIRE SIZE

Front	3.25 x 19	3.50 x 19	3.25 x 19
Rear	4.00 x 18	4.00 x 18	4.00 x 18

TIRE PRESSURE

Front lb./sq. in.	24	24	24
Rear lb./sq. in.	25	25	25

BULBS

Headlight—12 v. 50/40W Pre-focus... ..	Lucas 446	Lucas 446	Lucas 446
Parking Light—12 v. 4W M.C.C.	Lucas 222	Lucas 222	Lucas 222
Stop and Tail Light—12 v. 6/21W Offset pin ...	Lucas 380	Lucas 380	Lucas 380
Hi-beam and Ignition Warning Lights 2W BA7S	Lucas 281	Lucas 281	Lucas 281
Speedometer—12 v. 2W M.E.S.	Lucas 987	Lucas 987	Lucas 987
Fuse rating (amperes) ...	35	35	35

OVERALL DIMENSIONS

Length—in.	84½	84½	84½
Width—in.... ..	27	27	27
Overall Height—in. ...	38	38	38
Weight—lbs.	363	363	363

COLOR	Spring Gold	Spring Gold	Astral Red/ Silver
---------------------	-------------	-------------	-----------------------

GENERAL DESCRIPTION

This handbook refers to the Triumph motorcycles having a combined motor/gearbox unit of 650 c.c. (40 cu.in.) capacity. The vertical, parallel twin-cylinder, air cooled motor has overhead valves operated by push rods and has a bore of 71 m.m. (2.795 in.) and a stroke of 82 m.m. The motor is lubricated by pressure through a plunger pump from a 6 pint (U.S.) tank on the frame, the oil draining to the bottom of the crankcase where it is scavenged by the second part of the plunger pump and returned to the tank.

The primary drive is by Duplex chain and six-plate clutch contained in an oil bath chaincase. The four-speed foot-controlled gearbox is contained in the same housing as the motor but the lubrication systems are entirely separate. The gearbox is lubricated by oil contained in the housing. The final drive is by single chain.

The telescopic front forks are mounted in the frame by cup-and-cone ball bearings. The load is carried by two coil springs in compression and the movement is controlled by integral hydraulic damping which uses normal grade engine oil in each leg.

The rear suspension is a forked member pivoting on bronze bushes which are lubricated by periodical high-pressure greasing. The load is carried by Girling combined coil spring and hydraulic damper units. The spring is adjustable for load but the hydraulic system is completely sealed and needs no attention.

The front wheel size is 19 in. rim diameter with a 3.25 in. or 3.50 section front tire and an 8 in. diameter front brake. The rear wheel has a 4.00 x 18 section tire with a 7 inch diameter brake.

The electrical system is supplied from an alternating current generator contained in the primary chaincase and driven from the crankshaft. The output is fed through a silicon diode bridge connected rectifier to a 12 volt lead-acid battery. The voltage is controlled by a zener diode.

IMPORTANT NOTE

The positive side of the battery is grounded to the frame.

LAYOUT OF CONTROLS

Clutch lever. On left handlebar. The clutch couples the motor drive to the gearbox and rear wheel. Pull the lever towards the handlebar to disengage the clutch.

Horn-push and dipper switch. On left handlebar. Use the lever to change the headlight beam between the main and dipped positions, Press the domed top to sound the horn.

Air control. On right handlebar. Close the lever to the stop to richen the mixture only when starting a cold motor.

Front brake lever. On right handlebar. Pull the lever towards the handlebar to apply the front brake.

Throttle control. Twist the right handlebar grip towards you to increase the engine speed. Twist it away from you to reduce speed.

Speedometer. Indicates the speed and registers total and trip mileage. To set the trip indicator to zero twist the knob clockwise. Do not PULL the knob, as this is a snap fit in the speedometer.

Ignition switch. On left hand headlamp bracket, operated by a key. Turn the key clockwise to switch on ignition. The machine will start normally, even with a “flat” battery.

Lighting switch. The three position toggle switch on the headlamp. From the “off” position on left, move the switch right to the first notch for parking lights and to the second notch for full lights. Lights are not operative unless the ignition is switched ‘ON’.

Oil pressure warning light. Fitted into headlamp shell—illuminates as ignition is switched on and should extinguish with the engine running as oil pressure builds up. If it fails to extinguish with the motor running beyond tickover, kill the motor instantly and investigate the cause.

Hi-beam warning light. Shows as headlamp hi-beam is selected.

Kill button TR6C only. On right handlebar. Press to stop motor. Always switch off ignition and remove key when parking.

Ammeter. Indicates the rate of electrical current flow into or out of the battery.

Steering damper (TR6C ONLY). The large knob on the steering head. Turn clockwise to increase the friction on the steering for rough roads.

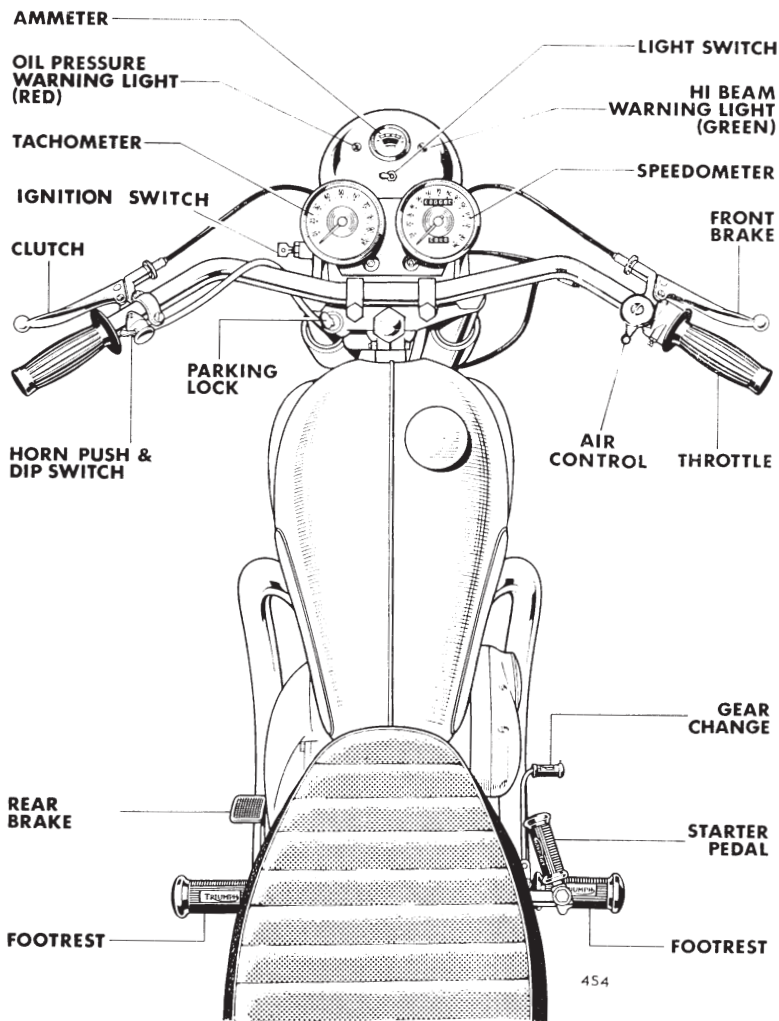

Fig. 1. Control Layout.

ON THE MACHINE

Gas taps. At the rear underneath the tank. Turn down the lever on the right tap for normal running. When the reserve is required turn down the lever on the left tap. Always turn off both taps when parking to prevent gas flooding the motor.

FOOT CONTROLS

Brake pedal. In front of left footrest. Press down to apply the rear wheel brake.

Gearshift lever. In front of right footrest. Press down to shift to a lower gear or pull up to shift to a higher gear. The lever is spring loaded and always returns to the central position.

Starter pedal. The folding pedal behind the right footrest.

TAKING THE MOTORCYCLE ON THE ROAD FOR THE FIRST TIME

In most cases the dealer will have checked the oil levels in the gearbox, primary chaincase and oil tank, checked the tire pressures and properly serviced the battery; if in doubt check them again. Replenish the gas tank with a suitable grade of fuel and the motorcycle is ready for starting.

TO START THE ENGINE

1. Select the neutral position between first and second gear.
2. Pull in the clutch lever and operate the starter pedal several times to free the clutch.
3. Turn on the gas tap and hold down for approx. 5 seconds the spring loaded tickler button which floods the carburetor and enrichens the mixture. In cold weather close the air lever to the stop.
4. Place the key in the ignition switch and turn clockwise.
5. Press down the starter pedal gently until you feel some resistance; then press harder with the throttle slightly open when the engine should start.

6. Open the air control as soon as the engine will allow it without stalling.

BREAKING IN YOUR NEW MOTORCYCLE

Although the new parts are machined as accurately as possible the moving parts need to mate with each other or become what is known as “break-in”. At a low constant speed this would take a considerable mileage, therefore the ideal method of running-in is to increase progressively the load and length of time the load is maintained. These machines will travel at 50 m.p.h. with only a small throttle opening on a level road without harm when new but any use of a large throttle opening, even in a lower gear, other than for a very short time may cause damage.

Shift gear frequently so that the engine is always working easily; neither pulling hard in a high gear nor revolving fast in a low gear. The extra use of the gearbox helps to run-in all the transmission parts. It is difficult to quote a set mileage but provided that the running-in is done intelligently it should be possible to use maximum performance after 1,500 miles. Whenever the maximum performance is used it is a good plan to snap shut the throttle for a moment occasionally as this sucks a certain amount of oil up the cylinders.

Be sure to take your motorcycle back to the dealer from whom you purchased it at 500 miles and have it serviced by him. Failure to have your dealer carry out the 500 mile free service check can result in the loss of benefit of the U.S. Triumph 90 day guarantee.

TO ADJUST THE VALVE OPERATING MECHANISM

There are four adjusters on the rockers which are accessible after removing the four inspection caps from the rocker boxes. The clearance must always be checked when the motor is cold and the correct figures for your model are listed in the Useful Data, page 5. It will be easiest to find the correct point of the stroke to adjust the valve clearance if you put the machine on the centre stand, engage top gear, and then remove the sparking plugs. By turning the rear wheel you can then turn the crankshaft and position the valves.

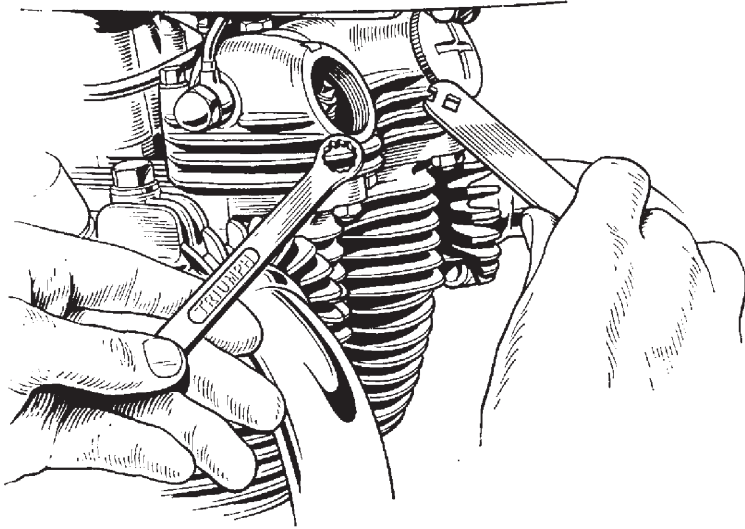

Fig. 2. To adjust the valve operating mechanism.

Inlet valves (Towards the rear of the engine)

Turn the rear wheel until one of the inlet rockers moves downwards, thus opening the valve. When this valve is fully open the operating mechanism of the other inlet valve will be seated on the base of the cam and the clearance can now be checked and adjusted if necessary. The clearance is 0.002 in. and this means just the slightest perceptible movement of the rocker with a faint click when the clearance is taken up by moving the rocker with the fingers.

Having adjusted one inlet valve, turn the rear wheel until the valve which you have adjusted is now fully open and repeat the procedure for the other inlet valve.

Exhaust valves

Having adjusted the inlet valves proceed to the exhaust valves which are the ones at the front of the engine. Proceed in the same way as for the inlet valves and put one valve fully open whilst you check the clearance on the other. In this case the clearance will be 0.004 in. To obtain this clearance adjust the tappet to give nil clearance and then turn back the adjuster one eighth of a turn (half a flat) on the squared adjuster. Hold the adjuster in this position whilst you tighten the lock nut. Repeat the procedure for the other exhaust valve.

A feeler gauge can be bent to fit into the rocker boxes to measure the clearance between the valve tip and adjuster screw.

Check that the inspection cap fiber washers are in good condition and replace the caps making sure that they are tight.

TO ADJUST THE BRAKES

Front brake

The adjustment of the front brake operating mechanism is by means of a knurled finger-operated nut incorporated in the handlebar abutment. Turn the nut anti-clockwise to take up the clearance in the operating cable. The exact setting will depend on the size of the rider's hand but the lever must not contact the handlebar when the brake is fully applied or the braking effect will be severely restricted.

Rear brake

The rear brake pedal is adjustable for position and any adjustment for the pedal position should be made before adjusting the free movement. From the static position before the brake is applied there should be about $\frac{1}{2}$ in. of free movement before the brake starts to operate. The actual adjustment is by means of a finger operated nut on the rear end of the brake operating rod. Turn the nut clockwise to reduce the clearance.

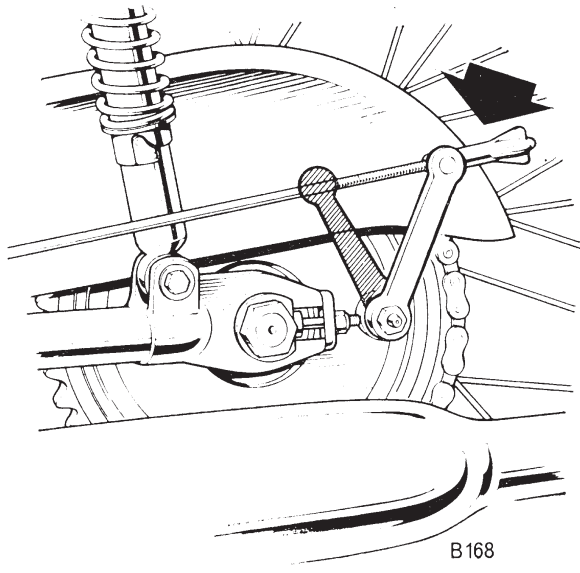
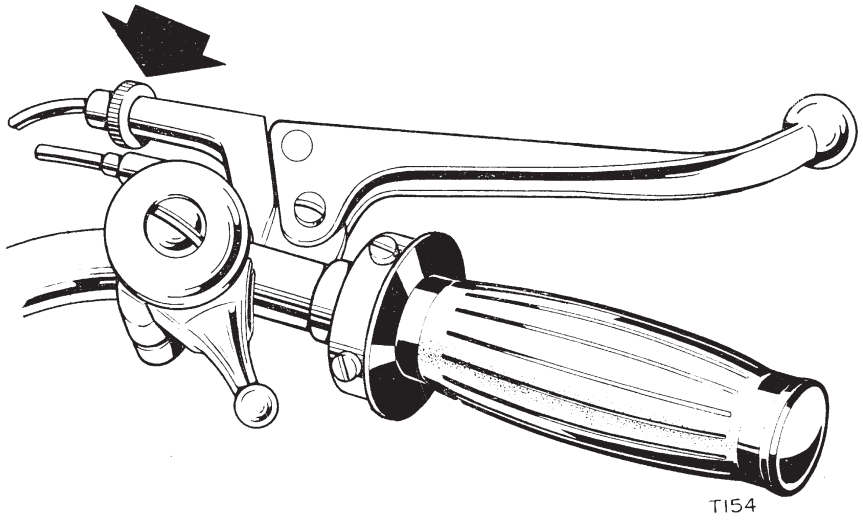

Fig. 3. Showing brake adjusters

TO ADJUST THE CHAINS

Primary chain

The primary chain is of the Duplex type and is not adjustable as the centres of the engine shaft and gearbox are fixed. Provision for the take-up of wear in the primary chain is made by means of a rubber-faced slipper blade below the bottom run of the chain. The free movement in the chain can be felt with a finger after removing the top inspection plug. Do not move the chain by using the starter pedal while your finger is inside the case. The correct chain adjustment is $\frac{1}{2}$ in. free movement. To reduce the amount of slack remove the plug with the extended head from the bottom of the case and tighten the slotted adjuster nut at the rear end of the tensioner by using the short screwdriver No. D496 supplied in the toolkit. After replacing the plug in the bottom of the chaincase always remember to replenish the oil with 350 c.c. of SAE 20 grade.

Rear chain

The adjustment of the rear chain is controlled by draw bolts fitted to each end of the rear wheel spindle. The correct adjustment for the rear chain is $\frac{3}{4}$ in. free movement with the machine on its wheels and the chain at its tightest point or $1\frac{3}{4}$ in. with the machine on the stand and the chain at its slackest point. If the adjustment of the chain is outside these limits it should be corrected by loosening the wheel spindle nuts and the brake torque stay nut on the anchor plate and then adjusting the draw bolts an equal number of turns. Always apply the brake pedal to centralise the brake plate and keep it applied while you tighten the left spindle nut. Tighten the wheel spindle nuts and check the chain adjustment again. If the wheel alignment was correct originally the adjustment of the nuts by an equal number of turns should preserve that alignment but if you are doubtful whether the rear wheel is in line then you should use a straight edge or piece of string alongside the rear wheel, making allowance for the difference in section between the rear tire and the front tire and then tighten or loosen the draw bolt adjuster on the right side so that the rear wheel lines up with the front wheel. If the rear wheel is not in line the road holding of the machine will be adversely affected and the effect on the rear chain and rear wheel sprocket will cause rapid wear. When the adjustment is satisfactory

check the tightness of the wheel spindle nuts, adjuster draw bolts and brake torque stay nuts. Finally check the adjustment of the brake operating rod. There is no automatic oil feed to the rear chain which should be lubricated manually with an oil gun weekly.

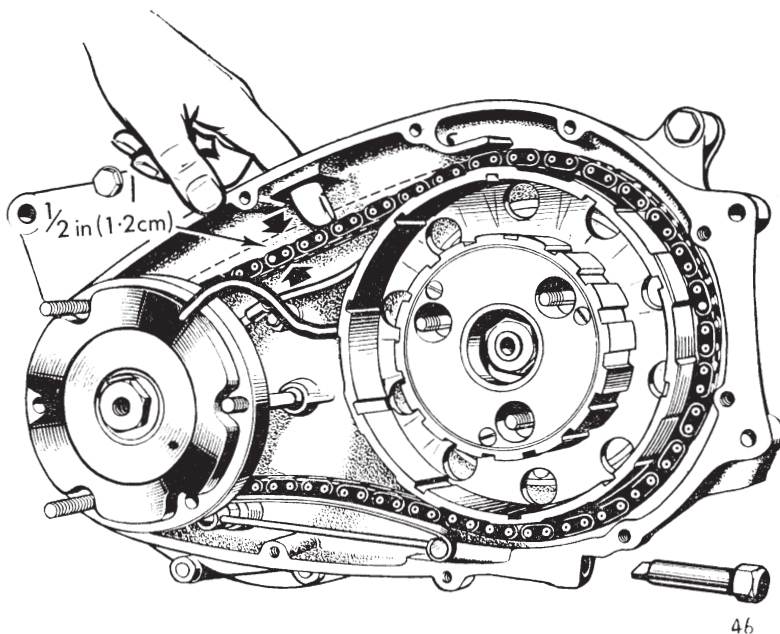

Fig. 4. To adjust the primary chain.

TO ADJUST THE CLUTCH AND THE CLUTCH OPERATING MECHANISM

The clutch is situated on the left side of the machine inside the primary chaincase. If the clutch is dragging and normal adjustment of the operating mechanism produces no improvement it will be

necessary to remove the primary chaincase to adjust the three springs which provide the loading on the pressure plate. To remove the primary chaincase first take off the left exhaust pipe and swing the footrest and brake pedal out of the way. Place a tray underneath, and release the cover by unscrewing two domed nuts and eight screws. The three slotted nuts on the clutch should be tightened initially until the heads are flush with the end of the pins. The handlebar clutch lever should be pulled and the starter pedal operated whilst you watch the outermost plate of the clutch. This should lift evenly and turn without wobbling. If one side of the plate is high the slotted nut nearest to it should be tightened as necessary until the pressure plate lifts and turns evenly. After replacing the cover replenish the oil with 350 cc. of SAE 20 grade. The correct level can be obtained by using the primary chaincase oil level plug situated at the rear of the chaincase at the 4 o'clock position, and partially obscured by the frame tube.

To adjust the clutch operating mechanism

When the clutch pressure plate lifts evenly it is then possible to adjust the clutch operating mechanism. Slacken off the adjustment at the handlebar end of the clutch cable and then screw in the adjuster situated in the centre of the pressure plate until the pressure plate just starts to lift. Screw back the adjuster one half turn and secure it with the locking nut. This adjustment can be carried out through the inspection hole in the primary chaincase if the chaincase has not been removed. Finally adjust the knurled nut at the handlebar abutment until there is approximately $\frac{1}{8}$ in. free movement in the cable. If it is required to take up excessive cable slack there is an adjuster fitted externally at the gearbox end of the cable.

To change the clutch cable

To remove the clutch cable slacken the adjustment at the handlebar abutment and then at the gearbox end of the cable. Pull the cable clear of the handlebar slotted adjuster and lever adjustment, disengaging the nipple from the lever. Slide the rubber cover upwards clear of the adjuster and remove the large filler plug from the gearbox outer cover. With a finger through this orifice the clutch cable nipple can be pushed clear of the internal clutch lever.

To replace the clutch cable, first pass the lower end through the rubber cover, bottom adjuster and abutment. Engage the cable nipple with the internal clutch lever. Pass the upper end of the cable through the slotted adjuster and abutment of the handlebar lever and fit the cable nipple to the lever. Slide the rubber cover into position at the gearbox end.

TELESCOPIC FRONT FORKS

The only routine attention needed to the front forks is checking the adjustment of the steering head races and changing the oil. Use Summer or Winter grade as specified on page 38 and change the oil in the Spring and Autumn even if the minimum mileage has not been covered.

To change the oil in the telescopic forks

Remove the small sloping bolt immediately above the wheel spindle on the outside of each fork leg. Allow the oil to drain into a suitable container and then remove the last drops by pressing on the handlebars and pumping the forks up and down. Replace the drain bolts, making sure that the small fiber washers are in good condition. To replenish the fork legs it will be necessary to remove the large chromium plated nuts at the top of the fork, and this should be done on each side separately with the machine on the centre stand. The correct quantity for each leg is shown on page 6.

To adjust the steering head races

The steering head races may require adjustment once or twice in the early stages of a machine's life but will rarely require attention after that. To check the adjustment, stand on the right side of the machine with the fingers of the left hand resting on the frame and the dust cover of the top bearing. With the right hand apply the front brake and rock the machine forward. Any play will be felt by the fingers of the left hand. To make the adjustment place the machine on the stand (and unscrew the steering damper knob TR6C only). Slacken the pinch bolt at the back of the fork top lug and tighten down the large adjusting nut on the fork stem until the play is just taken-up. The forks and wheel should turn freely from lock to lock

without any dragging or hesitation. If the adjustment seems correct but the movement is rough or jerky then the steering head races are probably damaged and it will be necessary to replace them. When the adjustment is correct tighten the pinch bolt (and steering damper TR6C only).

REAR SUSPENSION

The swinging fork pivots on bronze bushes which should be lubricated with a high pressure grease gun at least every 1,000 miles until grease is seen to be coming from the end of the left hand bush. There is one nipple only, beneath the centre of the fork bridge. If the mileage intervals are not convenient, it is better to grease more frequently rather than to extend the interval.

The movement is controlled by Girling combined coil spring and hydraulic damper units. The hydraulic damping mechanism is completely sealed but the static loading of the spring is adjustable. There is a three position castellated cam ring covered by a shroud below the chromium plated dust cover and a "C" spanner is provided in the toolkit. To increase the static loading of the spring place the machine on the stand so that there is least load on the spring and use the "C" spanner to turn the cam; both units must be on the same notch whichever may be chosen.

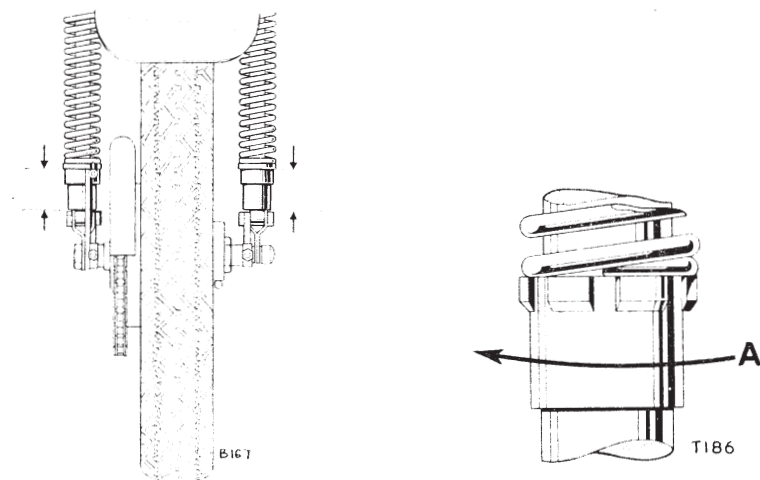

Fig. 5. Rear suspension spring adjustment.

A quick visual check can be made on this point from the rear of the machine as in Fig. 5. Comparing the exposed lengths of the units will establish that the loading is equal. To increase the static loading, turn the castellated cam ring in the direction shown. Alternative heavier springs are available to suit certain requirements and can be obtained from your dealer.

WHEELS

The wheel bearings are filled with grease on assembly and this should be sufficient to last for approximately 12,000 miles. In particularly dirty conditions it may be necessary to remove the bearings for cleaning and inspection at a lower mileage but this will usually be under cross-country conditions where the rider will be competent to take the decision to carry out this work. Always use the recommended grades of high melting point grease as hub temperatures rise during heavy braking and may cause a softer grease to melt and run into the brakes.

To remove the front wheel

Disconnect the brake operating cable by removing the spring pin at the bottom end. Unscrew the four bolts securing the two spindle caps to the fork legs, unscrewing each a little at a time until the four bolts are completely removed. By pressing down on the rear of the machine it will be possible to take out the wheel. To replace the front wheel engage the slot on the brake plate with the peg on the inside of the fork leg and place the spindle under the fork ends. Hold the caps in position and tighten the two bolts on the right hand leg completely before tightening on the left. This is to allow the end cap bolts to align properly in the wider left groove. Refit the brake cable and spring pin and adjust.

Rear wheel

The rear wheel has the brake drum bolted to the rear hub and the hub bearings are of the non-adjustable ball journal type. A detachable steel sprocket is bolted to the brake drum by eight bolts. Alternative sprocket sizes of 47–50 teeth are available from your dealer.

With hub bearings in good condition, there should not be any detectable side movement at the wheel rim.

To remove the rear wheel

Slacken the bolt at the rear of the chainguard so that the chainguard can be swung upwards. Make sure that the machine is in gear so that the chain does not fall off the gearbox sprocket and then remove the connecting link. Unscrew the nut from the end of the brake operating rod and if necessary disconnect the snap connector in the lead to the brake stop light to ensure that the light does not remain on. Unscrew the nut which secures the brake torque stay to the anchor plate and finally unscrew the wheel spindle nuts and speedometer drive cable and remove the wheel.

Replacement is the exact reverse of the removal procedure but always check the chain adjustment and wheel alignment, see Page 16

TIRES

The tire size is 3.25 or 3.50 x 19 front and 4.00 x 18 in. rear. The pressure should be checked regularly, preferably every two weeks. After checking the pressure the valve cap should always be replaced as it forms a seal against dirt and also prevents accidental deflation of the tire at high speeds.

The tire pressures recommended below are suitable for an average rider but if a pillion passenger is carried the pressure in the rear tire should be increased by 6 lbs./sq. in. and in the front tire by 4 lbs./sq. in.

<i>Tire size</i>		<i>Inflation pressure</i>
		lb./sq. in.
Front	3.25	24
Front	3.50	24
Rear	4.00	25

For further details consult the Dunlop booklet.

Front wheels are balanced complete with tire and tube before leaving the factory and if the tire is removed it should be replaced in the same position with the balancing spot level with the valve. If a

new tire is fitted the weights should be removed and the wheel re-balanced, adding weights as necessary until it will remain at rest in any position. Make sure that the brake is not binding while the balancing operation is being carried out. When balancing the rear wheel, the chain should of course be disconnected and removed from the rear wheel sprocket.

BRAKES

The rear brake shoes are semi-floating to allow them to centralise themselves in the drum. In the case of the rear brake the linings are at the trailing edges of the shoes and the shoes must be fitted to the anchor plate with the thrust pads against the fulcrum pin. Note that the leading and trailing shoes are not interchangeable.

The front brake is of the twin leading shoe variety on all models and the front brake shoes are identical.

BRAKES—REAR

The rear brake shoes can be centralised by slackening the nut holding the brake plate, and applying the brake. The nut should then be tightened while still maintaining pressure on the brake. If a thin wrench is not available, it may be necessary to remove the wheel to carry out this operation by gripping the spindle in a vice fitted with soft jaw pads to prevent damage to the spindle threads. When obtaining replacement brake shoes note that the leading and trailing shoes are not interchangeable.

IGNITION TIMING

The ignition contact breaker is in the timing cover on the right of the motor, and is driven by the exhaust camshaft. There is a round chromium-plated cover over it held by two screws. To remove the timing cover, for instance to examine the oil pump, the contact breaker (cam and auto-advance assembly) must be released from the camshaft. To release the contact breaker remove the central bolt and use extractor tool D782 by screwing it into the end of the hollow spindle.

When replacing the contact breaker it must be positioned correctly relative to the exhaust camshaft. A pin is provided in the exhaust camshaft and a slot in the taper end of the auto advance spindle serves as a location. The average owner will find the following method the easiest when setting the ignition timing.

For timing purposes two alternative methods have been used for setting the engine in the 38° fully advanced position. The first utilises service tool D2195 and D572. By turning the engine over gently with the service tool fitted in place of the blanking plug on the top rear of the crankcase, slight hand pressure on the plunger will enable this to locate with a slot cut into the flywheel for this purpose.

On later machines there are two slots in the flywheel, one at 38° and one at top dead centre (T.D.C.). When timing as above check with a sparking plug removed that the pistons are not at T.D.C. which would indicate the wrong slot being located. The T.D.C. plug is for degee plate use only.

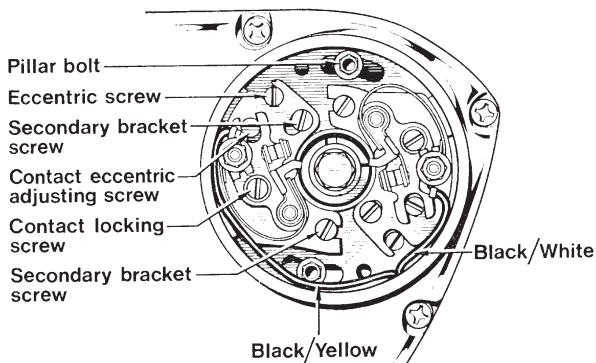

Fig. 6. Contact breaker, type 6CA.

The second method necessitates removal of the circular plate at the forward end of the primary chaincase. Through the aperture will be seen the timing marking on the rotor casting and this aligns with a pointer on the primary chaincase at the edge of the aperture. Placing the rotor marking in line with the pointer again gives the 38° timing position.

Remove both sparking plugs to facilitate turning over the engine. Set both sets of contact breaker gaps. (See page 31). Set the engine at 38° B.T.D.C. with the contact breaker turned clockwise to the fully advanced position. Check the left hand points (Black and Yellow lead) which should just be starting to open. If they are not, slacken both the pillar bolts and turn the contact breaker main backplate. Turn clockwise if the points open too early and vice versa. When correct, lock up the backplate, remove the flywheel locating plunger if used and turn the engine over slowly through 360° i.e. one revolution. Set the engine again at 38° B.T.D.C., check the cam is still at the fully advanced position and check that the second set of contacts (Black and White lead) are just starting to open. If there is any discrepancy, slacken the secondary backplate top and bottom screws (Fig. 6) and using the eccentric adjuster screw move the backplate to achieve the correct opening point.

The timing is now correct. The lubricating felt wicks adjacent with the contact breaker nylon heels are treated initially with Shell Retinax A grease and thereafter 3 drops of engine oil should be added to the ends of the wicks at each 2,000 mile interval.

SPARK PLUG

The spark plugs are 14 m.m. thread $\times \frac{3}{4}$ in. reach. The preferred grade is Champion N3.

Suitable alternative spark plugs of K.L.G. FE100 or FE220 (T120) grades may be used, but warmer plugs should be used for short distance use around town. It may be advisable to consult your dealer before varying the grade of plugs, as he will know local conditions and your type of use.

To remove a spark plug use the box spanner and short tommy bar provided in the toolkit. If the plug is difficult to unscrew, pour some penetrating oil round the threads and allow it to soak before continuing.

Every 3,000 miles remove the spark plugs and have them cleaned and tested on a plug cleaning machine. If there is no plug cleaning machine available use a penknife or wire brush to remove carbon

deposit. Measure the gap with feeler gauges; the correct setting is 0.025 in. To adjust the gap bend the side electrode but never the centre electrode. Every 10,000 miles fit new spark plugs.

When replacing the plug smear a little graphite grease or engine oil round the threads and make sure the joint washer is in good condition. Tighten with the box spanner and short tommy bar provided in the toolkit.

TO CLEAN YOUR MOTORCYCLE

Do not attempt to remove dried road dirt from your motorcycle, but use a copious supply of water from a hose or bucket containing some proprietary cleaner. Do not direct the water into the electrical system, air cleaner or brakes. Do not use abrasive cleaners on chromium plating but treat it in the same way as the painted surfaces. When the motorcycle is clean and dry, apply a wax polish.

TO CHANGE THE OIL

Whilst the machine is new it is necessary to change the oil in the motor oil tank, gearbox and primary chain case. The reason for this is that the running-in process previously mentioned is a type of controlled wearing and minute particles of metal are produced in this process particularly during the very early stages.

The Dealer will drain the motor and oil tank, and clean out the gauze filter in the tank during the 500 mile free service.

It is advisable to have this operation carried out again at 1,500 miles and at the same time have the gearbox and primary chaincase drained and flushed. Whenever the oil is changed it is advisable to do it when the oil is hot and when the majority of the foreign matter is in suspension. The regular oil change period is every 1,500 miles.

MOTOR AND OIL TANK

There is a gauze strainer in the crankcase which is removable for cleaning by unscrewing the hexagon-headed plug which slopes from left to right under the motor. Remove the drain plug and disconnect the feed pipe at the threaded union and unscrew the upper part of the union which has attached to it the oil tank gauze filter. Rinse the filters in clean kerosine. Remove all foreign matter from the inside

of the tank and finally rinse it in the same way. Replace the filters, with new fiber washers when necessary, and replenish the oil tank to the "full" position on the dipstick. Start the motor and immediately check the oil issuing from the oil tank return pipe. The filler cap dipstick is calibrated "Add one pint" for topping up purposes.

GEARBOX

The drain and level plugs are situated underneath the gearbox, see illustration. To drain the gearbox remove the assembly. When you are ready to replenish the gearbox replace only the drain plug with the level tube and then add oil to the gearbox through the side filler hole until oil just begins to flow down the level tube, then replace the level plug.

When checking the level remember that normally there will be some oil trapped in the level tube which should be allowed to drain before topping up commences.

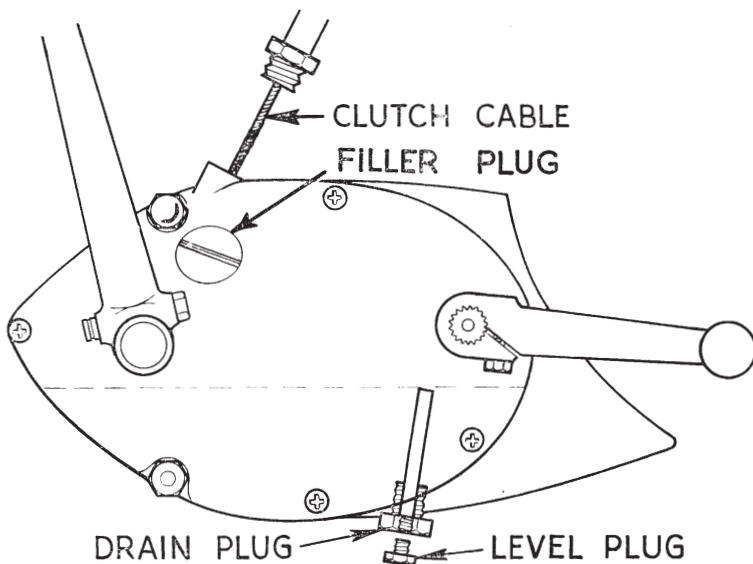

63

Fig. 7. Gearbox drain and level plugs.

PRIMARY CHAINCASE

The primary chaincase oil level is automatically maintained by the engine crankcase breathing system. Only after the lubricant has been

drained off or lost during adjustment of the primary chain is it necessary to refill using the level plug at the front of the outer portion of the chaincase at the 7 o'clock position. The drain plug is in the bottom of the outer portion of the chaincase.

THE AMAL CONCENTRIC CARBURETOR

How it operates

When the motor is idling, mixture is supplied from the pilot jet system, then as the throttle slide is raised, via the pilot by-pass. The mixture is then controlled by the tapered needle working in the needle jet and finally by the size of the main jet. The pilot system is supplied by a pilot jet, which is non-detachable and which is located in the mixing chamber body. The main jet does not spray directly into the mixing chamber but discharges through the needle jet into the primary air chamber and the fuel goes from there as a rich fuel-air mixture through the primary air choke into the main air choke.

This primary air choke has a compensating action in conjunction with bleed holes in the needle jet, which serve the double purpose of air-compensating the mixture from the needle jet and allowing the fuel to provide a well, outside and around the needle jet, which is available for snap acceleration.

Adjustment of carburetor parts

Throttle stop screw. This screw should be set to open the throttle sufficiently to keep the engine running at a slow tick-over, when the twistgrip is closed.

Pilot air screw

To set the idling mixture, this screw should be set in to enrich or out to weaken, normal number of turns out from full in is about $2\frac{1}{2}$. The screw controls the suction on the pilot jet by metering the amount of air which mixes with the gasoline.

Needle and needle jet

Machines are delivered from the factory with the needle in the correct position, which should not be altered.

Throttle valve cut-away

The amount of cut-away is recorded by a number marked on the throttle, viz. 928/ $2\frac{1}{2}$ means throttle type 928 with No. $2\frac{1}{2}$ cut-away;

a larger cut-away such as 4 gives a weaker mixture or a smaller such as 3 gives a richer mixture.

For settings see Useful Data on Page 6.

Air filter

The air filter has a cloth element. To detach the element, release the clip on the perforated metal rim. Tap the element gently at the same time as a jet of compressed air is directed at it. Never oil the element in this type of filter.

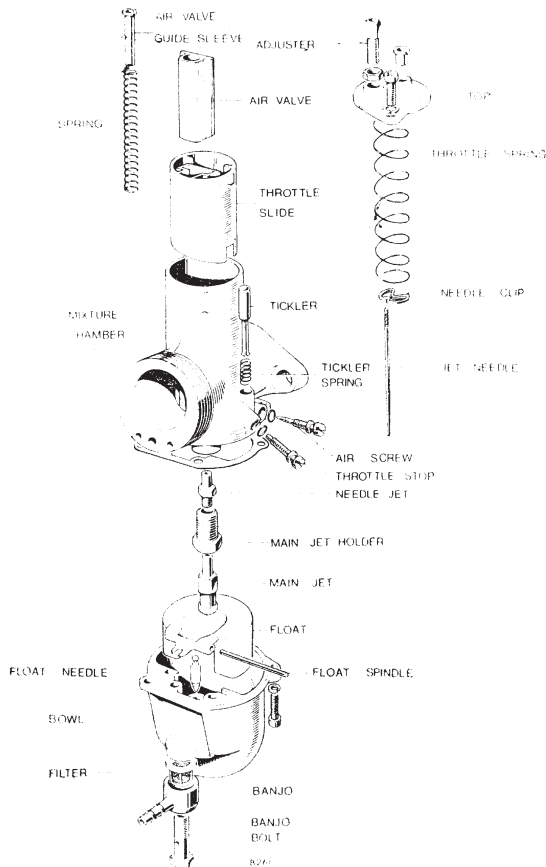

Fig. 8. Amal concentric carburetor.

Twin Carburetors

The twin carburetors fitted to the T120R may require synchronisation and a simple method is as follows:—First adjust the cables so that they have the minimum of free play. Now start the motor and take off one plug lead and then adjust the pilot air screw and throttle stop screw in the OPPOSITE carburetor until the motor runs regularly. Replace the plug lead and repeat the process similarly for the other carburetor. With both plug leads replaced the tickover will be too fast and the stop screws should be lowered simultaneously until correct. It is most important the throttle slides lift simultaneously or the motor will run roughly, particularly when accelerating.

Effect of altitude on carburation

Increased altitude tends to produce a rich mixture. The greater the altitude, the smaller the main jet required. As supplied from the factory, carburetor settings are suitable for altitudes of up to 3,000 feet approximately. Machines used constantly at altitudes 3,000 to 6,000 feet should have the main jet size reduced by 5 per cent and thereafter for every 3,000 feet in excess of this, further reductions of 4 per cent should be made.

ELECTRICAL EQUIPMENT

The electrical system is supplied from an alternating current generator contained in the primary chaincase and driven from the crankshaft. The generator output is then converted into direct current by a silicon diode rectifier. Direct current is supplied to the battery provided on the machine with a Zener diode in circuit to regulate the current that the battery receives, this depending entirely on the state of charge of the battery. The current is then supplied to the ignition system which is controlled by a double contact breaker driven direct from the exhaust camshaft. The contact breaker feeds two ignition coils, one for each cylinder.

In the case of a flat battery the machine can still be started without difficulty by switching on the ignition as with the normal starting procedure.

The routine maintenance needed by the various components is set out in the following paragraphs. All electrical components and connections including the ground points to the frame of the machine must be CLEAN and TIGHT.

Contact breaker unit, Type 6CA

The contact breaker is contained behind the round chromium plated cover held by two screws on the right side of the motor. See Fig. 6, Page 24. The nylon heels of the moving contacts may settle down initially and it is necessary to check both contact breaker gaps after 500 miles. After checking, apply 3 drops of engine oil to each lubricating wick.

To adjust the contact breaker gap, turn the motor with the starter pedal until the scribe mark on the cam aligns with the nylon heel of one set of points. Measure the gap (0.015 in.) with feeler gauges. If they are outside the limits, slacken the slotted screw which secures the stationary contact and move the contact until the gap is correct, then tighten the slotted screw. Turn the motor forward until the second pair of contacts just open and adjust them in the same way.

Every 3,000 miles subsequently, inspect the contact breaker points and if they are burnt or pitted remove them from the base plates and clean them with fine emery cloth. Wipe with a clean cloth moistened with gasoline. Replace the contacts on the base plate making sure that any insulating washers are in their correct positions. Adjust the gap and then clean the second pair of contacts. Place a few drops of clean engine oil on the centrifugal automatic advance mechanism and one or two drops on the felt pad which lubricates the cam. Two drops of oil should also be applied to the spindle which supports the cam to prevent corrosion and possible seizure. Do not allow any oil on the contacts. Initially the lubricating felts are treated with Shell Retinax A grease and thereafter 3 drops of engine oil should be added to the wicks at 2,000 mile intervals.

Ignition coils, Type 17M12

The twin ignition coils are mounted to the frame beneath the gas tank. Keep the tops of the coils clean particularly beneath the electrical terminals. Inspect the cables for frayed wires or damaged insulation. Any damaged section of cable must be replaced. The coils should be positioned so they cannot short circuit against the gas tank.

Battery, Type PUZ5A

A Lead/acid battery is carried beneath the hinged twin seat. Keep the top and the terminals clean. During charging the battery produces gas and this may carry some acid. Wipe up any liquid as it will cause corrosion if it is allowed to remain on metal parts. Check the acid level every week.

Do not overfill a battery. The electrolyte level should be just above the plates of the battery. Add distilled water until the liquid reaches this point. With this type of battery the acid can be reached by a hydrometer, which will indicate the state of charge. If you suspect a faulty battery have it checked by any Triumph dealer. *When replacing the battery on the machine always connect the red (+) positive terminal to the frame of the machine (ground).*

Lighting and ignition switches

When the ignition is switched off, the current to both the ignition and lighting circuits is cut off. It is therefore not possible to start the machine or to turn on the lights. The switches are sealed and if a fault is suspected, test by substituting another switch. The three connectors should be held firmly in contact with the body of the switch and this should be checked from time to time to ensure constant good electrical contact. An ignition cut out "kill" button

is provided on the right handlebar. The oil warning lamp also tells the rider that he has not switched off the ignition with the key provided. It is advisable to make a note of the number of the key in case of subsequent loss.

Alternator, Type RM19

The alternator is contained in the primary chaincase and has no wearing parts. Check that the snap connectors are clean and tight in the output cable to the rear of the engine unit.

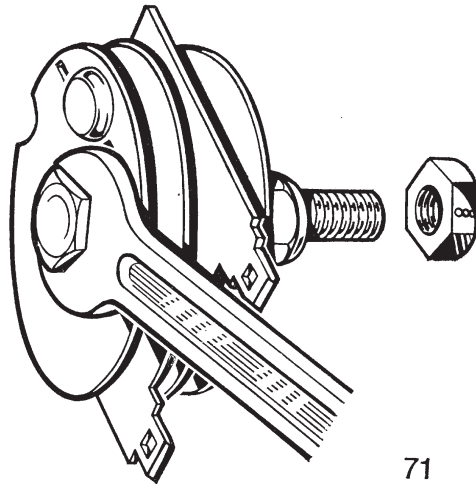

Fig. 9. To secure the rectifier.

Rectifier, Type 2DS506

The central fixing bolt of the rectifier must make electrical contact with the frame of the motorcycle. When tightening a rectifier hold the spanners as shown in the illustration above. Never disturb

the self-locking nut which clamps the plates together. If the plates are twisted the internal electrical connections will be broken. Note that the fixing bolt and nut are $\frac{1}{4} \times 28$ U.N.F. thread and are both marked by circles to indicate this thread form.

ZENER DIODE

The Zener diode is a small electronic device that acts as a by-pass valve to divert surplus charging current away from the battery. It acts as a voltage regulator, and controls the current into the battery, and is mounted on a finned "heat sink" to ensure efficient cooling. Care must be taken therefore not to impair the flow of air around the heat sink.

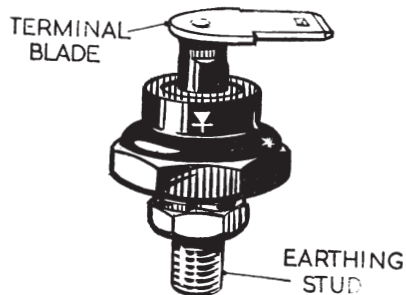

Fig. 10. Zener diode, Model ZD715.

Providing the diode and its heat sink are kept clean, to ensure maximum efficiency, no maintenance will be necessary.

Caution. The body of the Zener diode is made of copper to ensure maximum heat conductivity. This means that the fixing stud has a relatively low tensile strength, and should not be subjected to a tightening torque greater than 2 lbs. ft.

Fuse

A line fuse is included in the electrical circuit on later machines, and is located in the battery live lead. It consists of a plastic tubular holder with a standard 35 ampere rating fuse spring loaded and held in position by a bayonet type fixing cap on the end of the holder. This connection should be checked to ensure that it is clean and tight. It may be necessary to increase the fuse rating if additional electrical equipment is subsequently fitted to the machine. The machine must not be run with a "blown" fuse, otherwise serious damage will result.

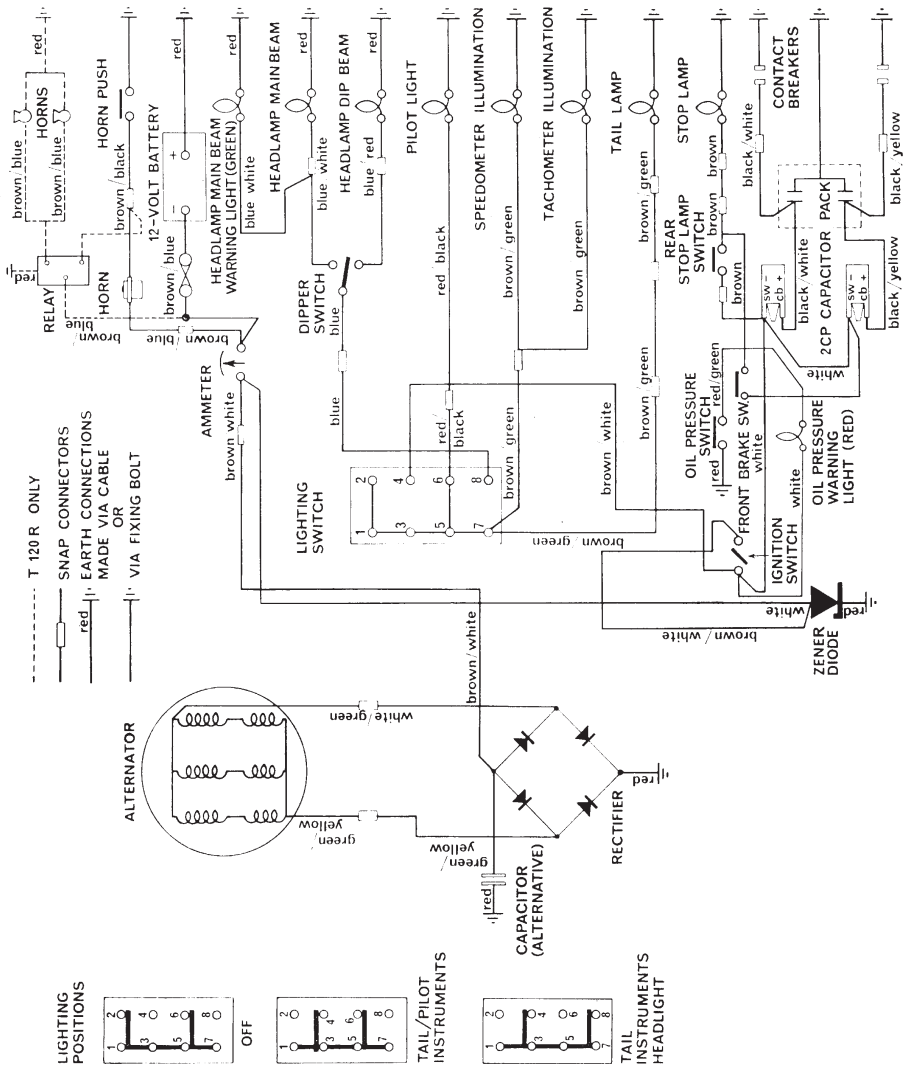

Fig. 11. Wiring diagram, all models.

Stoplamp switches

Switches are fitted front and rear. The front switch is fitted into the brake cable and the rear to the rear chainguard operated by the rear brake rod. The switches are sealed units but the rear one can be adjusted for position.

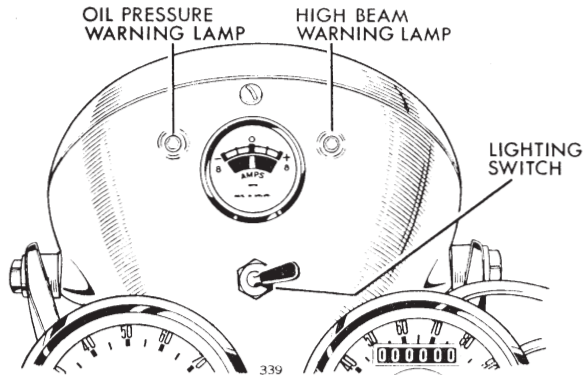

Fig. 12. Headlamp showing lighting switch, ammeter and warning lights.

Windtone horns. T120R only.

The windtone horns are fitted beneath the front of the petrol tank. The relay is mounted beneath the tank. These units are non-adjustable and require no maintenance beyond an occasion check on the cleanliness and security of electrical connections.

CAPACITOR IGNITION

Provision is made on TR6C models for the direct fitting of a capacitor and mounting spring. The wiring harness is already equipped for the conversion and it is necessary only to remove the battery from the carrier, fit the capacitor and spring, connect the battery live lead to the double spade terminal and the capacitor red terminal to earth. Full headlamp, tail lamp and horn are still operative with the engine running. It is essential that the capacitor is of the correct rating and capacity.

CONDENSER PACK 2 CP

The two condensers are mounted on a common plate with a rubber shroud. The condenser pack is located beneath the forward petrol tank mounting, between the reflectors.

ROUTINE MAINTENANCE

	<i>Page</i>
Every week. Check battery acid level	32
Every two weeks. Check tire pressure	22
Every 250 miles	
Check level in oil tank	27
Every 1,000 miles	
Lubricate and adjust control cables including brakes	General
Grease swinging fork pivot	20
Check front chain adjustment	16
Check rear chain adjustment	16
Check nuts, bolts and screws for tightness	General
Add two drops of oil to C/B cam spindle	32
Every 1,500 miles	
Change engine oil	27
Every 2,000 miles	
Lubricate the contact breaker	31
Every 3,000 miles	
Check gearbox oil level	28
Check adjustment of valve operating mechanism	12
Clean and adjust spark plugs	26
Clean and adjust contact breaker	31
Clean air filter	29
Check ignition timing	25
Every 6,000 miles	
Change oil in gearbox	27
Change oil in front forks	19
Check adjustment of steering head bearings	19
Every 12,000 miles	
Clean and grease wheel bearings	Workshop Manual
Clean and grease steering head bearings	Workshop Manual

RECOMMENDED LUBRICANTS U.S.A.

UNIT	VALVOLINE	MOBIL	B.P.	CASTROL	ESSO	SHELL	TEXACO
Engine and Primary Chaincase							
Above 90°F ...	} Valvoline SAE.30 Valvoline SAE.20	} Mobiloil Super 10W/50	} B.P. Super Visko-Static 20W/50 10W/30	} Castrol XLR Castrolite	} Uniflo	} Shell Super 100 or Shell Super 101	} Havoline 20W/50 Havoline 20/20W
32°—90°F ...							
Below 32°F ...							
Gearbox ...	Valvoline EP90	Mobilube GX90	B.P. Gear Oil EP90	Castrol Hypoy 90EP	Gear Oil GX90	Spirax 90EP	Multigear Lubricant 90EP
Telescopic Fork							
Above 90°F ...	} Valvoline SAE.30 Valvoline SAE.20	} Mobiloil Super 10W/50	} Energol SAE.30 Energol SAE.20W	} Castrol SAE.20W	} Uniflo	} Shell X-100 30 Shell X-100 20W	} Havoline 30 Havoline 20-20W
60°—90°F ...							
Wheel Bearings, Swinging Fork, Steering Races	Valvoline Hi-Melt Grease	Mobilgrease MP Mobilgrease Special	Energol L2	Castrol LM Grease	Multipurpose Grease H	Shell Retinax A	Marfak All purpose
Easing Rusted Parts ...	Valvoline Penetrating Oil	Mobil Handy Oil	Energol Penetrating Oil	Castrol Penetrating Oil	Esso Penetrating Oil	Shell Donax P	Graphited Penetrating Oil

The above Heavy Duty (H.D.) Oils meeting A.P.I. Classifications ML., MM. and MS. are recommended.

GUIDE TO LUBRICATION POINTS

Illustration No.	Description	SAE Oil grade
1	Engine oil tank	20 or 30
2	Gearbox	50
3	Primary chaincase	20
4	Wheel hubs	Grease
5	Steering head	Grease
6	Brake cam spindle	Grease
7	Brake pedal spindle	Grease
8	Exposed cables	20
9	Telescopic fork	SAE 20
10	Swinging fork pivot	Grease
11	Contact breaker	20
—	All brake rod joints and pins ...	20

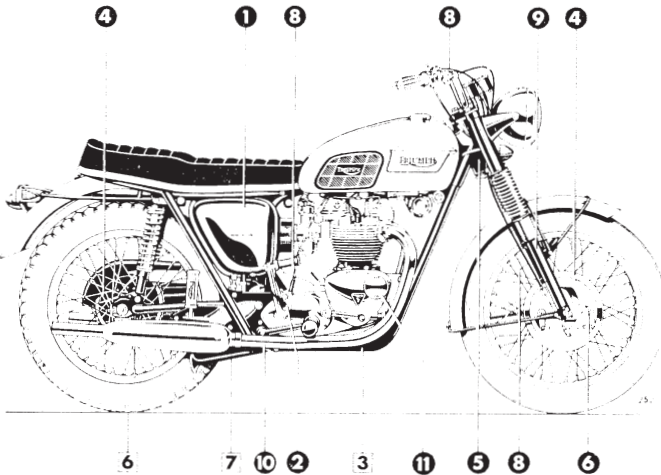

Numbers in circles refer to right side of machine.
 Numbers in squares refer to left side of machine.

Fig. 13. Lubrication points

The following information is in accordance with the requirements of the U.S. Federal Highway Administration, Department of Transportation.

This figure indicates braking performance that can be met or exceeded by the vehicles to which it applies, without locking the wheels, under different conditions of loading.

The information presented represents results obtainable by skilled drivers under controlled road and vehicle conditions, and the information may not be correct under other conditions.

Description of vehicles to which this table applies:—
TRIUMPH T120R BONNEVILLE

A. Fully Operational Service Brake

LOAD
LIGHT
MAXIMUM



Stopping distance in feet from 60 m.p.h.

This figure indicates passing times and distances that can be met or exceeded by the vehicles to which it applies, in the situations diagrammed below.

The low-speed pass assumes an initial speed of 20 m.p.h. and a limiting speed of 35 m.p.h. The high-speed pass assumes an initial speed of 50 m.p.h. and a limiting speed of 80 m.p.h.

Notice:—The information presented represents results obtainable by skilled drivers under controlled road and vehicle conditions, and the information may not be correct under other conditions.

Description of vehicles to which this table applies:—
AS ABOVE

Summary Table

LOW-SPEED PASS 363 feet; 7.5 seconds

HIGH-SPEED PASS 1,015 feet; 10.3 seconds

LOW-SPEED
INITIAL SPEED:

20 MPH

LIMITING SPEED: 35 MPH

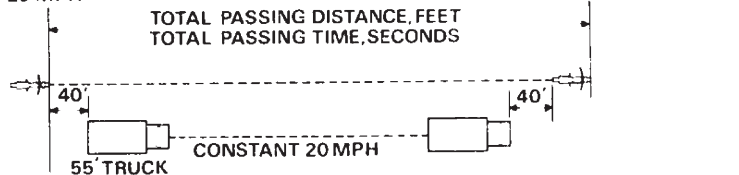

HIGH-SPEED
INITIAL SPEED:

50 MPH

LIMITING SPEED: 80 MPH

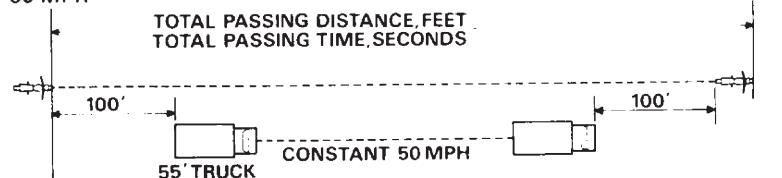

The following information is in accordance with the requirements of the U.S. Federal Highway Administration, Department of Transportation.

This figure indicates braking performance that can be met or exceeded by the vehicles to which it applies, without locking the wheels, under different conditions of loading.

The information presented represents results obtainable by skilled drivers under controlled road and vehicle conditions, and the information may not be correct under other conditions.

Description of vehicles to which this table applies:—
TRIUMPH TR6R TIGER 650 & TRIUMPH TR6C TROPHY 650

A. Fully Operational Service Brake

LOAD
LIGHT
MAXIMUM.

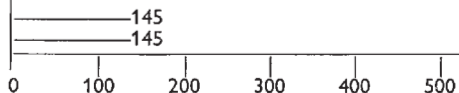

Stopping distance in feet from 60 m.p.h.

This figure indicates passing times and distances that can be met or exceeded by the vehicles to which it applies, in the situations diagrammed below.

The low-speed pass assumes an initial speed of 20 m.p.h. and a limiting speed of 35 m.p.h. The high-speed pass assumes an initial speed of 50 m.p.h. and a limiting speed of 80 m.p.h.

Notice:—The information presented represents results obtainable by skilled drivers under controlled road and vehicle conditions, and the information may not be correct under other conditions.

Description of vehicles to which this table applies:—
AS ABOVE

Summary Table

LOW-SPEED PASS 364 feet; 7.6 seconds

HIGH-SPEED PASS 1,115 feet; 11.6 seconds

LOW-SPEED
INITIAL SPEED:

20 MPH

LIMITING SPEED: 35 MPH

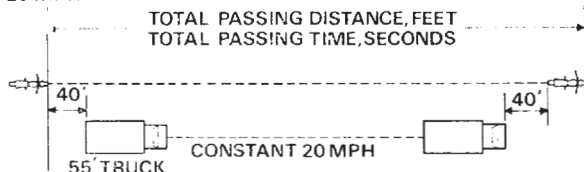

HIGH-SPEED
INITIAL SPEED:

50 MPH

LIMITING SPEED: 80 MPH

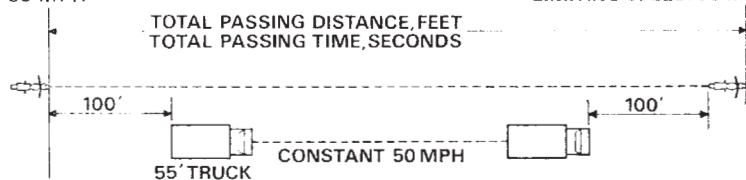

IMPORTANT NOTE

The fitting of components which are not approved by the manufacturer invalidates the guarantee.

Printed in England by
WARWICK PRINTING COMPANY LIMITED
WARWICK
